

Cable Tray

CT-16

B-LINE
SERIES

Cable tray systems



EATON

Powering Business Worldwide

Cable Tray Systems

Cable tray is a mechanical support system that can support cables and raceways. Cable tray is not a raceway. Cable tray systems are required to be electrically continuous but not mechanically continuous.

Advantages of Eaton's B-Line series Cable Tray Systems

- **Safety**
- **Dependability**
- **Space Savings**
- **Cost Savings**
- **Design Cost Savings**
- **Material Savings**
- **Installation Cost & Time Savings**
- **Maintenance Savings**

For more information refer to the Cable Tray Manual (Pages MAN-1 thru MAN-53) or call us at 1-800-851-7415

Quick List Selection Process

See pages C-20 & C-21 for expanded selection process.

1. Support Span Issues are: Strength and Length

It is very important to first consider the support span as it affects the strength of the system and the length of the straight sections required.

- Short Span, 6 to 8 foot support spacing - use 12 foot sections.
- Intermediate Span, 8 to 12 foot support spacing - use 12 foot sections.
- Long Span, 16 to 20 foot support spacing - use 20 foot sections.
- Extra Long Span, over 20 foot to 30 foot support spacing - use 24 or 30 foot sections.

2. Working Load Issues are: Size (Width, Loading Depth, and Strength)

Cable Load

- Types and numbers of cables to support - Total cable load in lbs. per linear foot (lbs/ft)
- Power - is single layer - issue width (refer to local electrical code)
- Low Voltage - is stacked - issue loading depth and width (refer to affecting code)
- See chart of listed cable load guidelines (refer to page C-24)

Additional Loads

- 200 lb. concentrated load - Industrial installations
- Ice, Wind, Snow loads - Outdoor installations

Select a Cable Tray system that meets the working load for the support span required and a straight section length that fits the installation. NEMA VE 2 - Straight sections equal to or larger than span.

Eaton.com/cabletray

3. Installation Environment Issues are: Material and Finish

- Indoor Dry - Institutional, Office, Commercial, Light Industrial
Aluminum, Pre-Galvanized Steel
- Indoor Industrial - Automotive, Pulp and Paper, Power Plants
Aluminum, Pre-Galvanized Steel, Possibly Hot-Dipped Galvanized After Fabrication (HDGAF)
- Outdoor Industrial - Petrochemical, Automotive, Power Plants
Aluminum, Hot-Dipped Galvanized After Fabrication (HDGAF)
- Outdoor Marine - Off Shore Platforms
Aluminum, Stainless Steel, Fiberglass
- Special - Petrochemical, Pulp and Paper, Environmental Air
Contact B-Line (1-800-851-7415)

Cable Tray Product Offering

1.Support Span Issues are: Strength and Length

It is very important to first consider the support span as it affects the strength of the system and the length

Two Side Rail Systems

- Aluminum, Pre-Galvanized Steel, Hot Dip Galvanized After Fabrication Steel, 304 and 316L Stainless Steel, Fiberglass in Polyester Resin, Vinyl Ester, Zero Halogen, and Dis-Stat
- Systems tested to 100+ lbs/ft on a 40 foot span
- Special bottom options and splices
- Highest quality fittings
- Unmatched accessories supplied with attachment hardware

Cable Channel (See Cable Channel Section - pages E-1 – E-6)

- 3, 4, and 6 inch widths in Aluminum, Pre-Galvanized Steel, Hot Dip Galvanized after Fabrication Steel and 304 or 316L Stainless Steel
- 3, 4, 6, and 8 inch widths in Fiberglass in Polyester Resin, Vinyl Ester, Zero Halogen, and Dis-Stat
- Unmatched fitting and accessory offering
- Special bottom options and splices
- Highest quality fittings
- Unmatched accessories supplied with attachment hardware

FLEXTRAY™ Wire Basket (See FLEXTRAY Section - pages D-1 – D-58)

- One of the best finishes in the industry, ASTM B633, SC2 (ZN)
- Strong straight top wire design maximizes strength and minimizes weight
- Unmatched accessory package

Advantage of Using Eaton's B-Line series Cable Tray? Selection!

What kind of B-Line series cable tray will work for your project?

First, answer three questions.

- 1. Location:** Where will the project be located?
 - A.** Is the installation inside or outside?
(decision dealing with thermal and weather conditions)
 - B.** Any contact of corrosive materials?
(decision on cable tray material or finish)
 - C.** Is the location for the cable tray confined or open?
(decision on the size and type of cable tray)
- 2. Span:** What would be the longest and shortest spans between supporting locations for the installation of cables? (decision on type or combination of types of cable tray design needed to be the most efficient and economical)
- 3. Cables:** How many and what type of cables are involved in the support installation?
(decision on the strength of the cable tray)

All these variables are important to the cost savings and safety of Eaton's B-Line series Cable Tray installation project.

Important notice: The information herein has been carefully checked for accuracy and is believed to be correct and current. No warranty, either expressed or implied, is made as to either its applicability to or its compatibility with specific requirements of this information, nor for damages consequential to its use. All design characteristics, specifications, tolerances and similar information are subject to change without notice.

Short Span 6 - 8 Foot (distance between the supports)

Recommended Short Span Cable Tray Selection Use 10 ft or 12 ft Sections

	Catalog Number	Rail Height	Load Depth	Span Load lbs/ft		Available Widths	Material*	Straight Sections & Accessories Pages	Fittings Pages
				6'	8'				
FLEXTRAY™	FT2X2X10	2.380"	2.000"	28	20	2"	S	D-4 – D-6 & D-8 – D-56	—
	FT2X4X10	2.380"	2.000"	43	27	4"	S	D-4 – D-6 & D-8 – D-56	—
	FT2X6X10	2.380"	2.000"	47	27	6"	S	D-4 – D-6 & D-8 – D-56	—
	FT2X8X10	2.380"	2.000"	47	27	8"	S	D-4 – D-6 & D-8 – D-56	—
	FT2X12X10	2.380"	2.000"	47	27	12"	S	D-4 – D-6 & D-8 – D-56	—
	FT2X18X10	2.380"	2.000"	47	27	18"	S	D-4 – D-6 & D-8 – D-56	—
	FT2X20X10	2.380"	2.000"	47	27	20"	S	D-4 – D-6 & D-8 – D-56	—
	FT2X24X10	2.380"	2.000"	47	27	24"	S	D-4 – D-6 & D-8 – D-56	—
	FT4X4X10	4.380"	4.000"	49	36	4"	S	D-4 – D-6 & D-8 – D-56	—
	FT4X8X10	4.380"	4.000"	77	46	8"	S	D-4 – D-6 & D-8 – D-56	—
	FT4X12X10	4.380"	4.000"	83	47	12"	S	D-4 – D-6 & D-8 – D-56	—
	FT4X18X10	4.380"	4.000"	83	47	18"	S	D-4 – D-6 & D-8 – D-56	—
	FT4X20X10	4.380"	4.000"	83	47	20"	S	D-4 – D-6 & D-8 – D-56	—
	FT4X24X10	4.380"	4.000"	89	50	24"	S	D-4 – D-6 & D-8 – D-56	—
	FT6X12X10	6.380"	6.000"	86	48	12"	S	D-4 – D-6 & D-8 – D-56	—
	FT6X18X10	6.380"	6.000"	89	50	18"	S	D-4 – D-6 & D-8 – D-56	—
FT6X20X10	6.380"	6.000"	98	55	20"	S	D-4 – D-6 & D-8 – D-56	—	
FT6X24X10	6.380"	6.000"	107	60	24"	S	D-4 – D-6 & D-8 – D-56	—	
Cable Channel	ACC-03	1.250"	1.250"	15	10	3"	A	E-3 – E-4 & E-5 – E-9	E-10 – E-17
	ACC-04	1.750"	1.750"	33	20.5	4"	A	E-3 – E-4 & E-5 – E-9	E-10 – E-17
	ACC-06	1.750"	1.750"	36	22.5	6"	A	E-3 – E-4 & E-5 – E-9	E-10 – E-17
	†CC-03	1.250"	1.250"	17	11.5	3"	S, SS_	E-3 – E-4 & E-5 – E-9	E-10 – E-17
	†CC-04	1.750"	1.750"	36	24.5	4"	S, SS_	E-3 – E-4 & E-5 – E-9	E-10 – E-17
	†CC-06	1.750"	1.750"	41	28	6"	S, SS_	E-3 – E-4 & E-5 – E-9	E-10 – E-17
	FCC-03	1.000"	1.000"	8	—	3"	F	M-49	M-50 & M-51
	FCC-04	1.125"	1.125"	12	—	4"	F	M-49	M-50 & M-51
FCC-06	1.625"	1.625"	58	—	6"	F	M-49	M-50 & M-51	
FCC-08	2.188"	2.188"	87	—	8"	F	M-49	M-50 & M-51	
Cable Tray Steel	148	3.625"	3.077"	204	115	6" - 36"	S	H-3 - H-6 & H-7 – H-16	H-18 – H-26
	156	4.188"	3.628"	304	171	6" - 36"	S	H-3 - H-6 & H-7 – H-16	H-18 – H-26
	166	5.188"	4.628"	308	173	6" - 36"	S	H-3 - H-6 & H-7 – H-16	H-18 – H-26
	176	6.188"	5.628"	-	194	6" - 36"	S	H-3 - H-6 & H-7 – H-16	H-18 – H-26
	13F	3.000"	2.000"	257	145	6" - 24"	F	M-21 & M-45 – M-48	M-27 – M-44

*Material: A = Aluminum • S = Steel • SS_ = Stainless Steel Type 304 or 316 • F = Fiberglass

† = G for HDGAF • P for Pre-Galvanized • SS4 for 304 or SS6 for 316 Stainless Steel

① Insert 2, 3, 4, 5 or 6 for number of tiers • ② Insert 2, 3 or 4 for number of tiers

Recommended Intermediate Span Cable Tray Selection
Use 12 ft Sections

Intermediate Span 10 - 12 Foot
(distance between the supports)

	Catalog Number	Rail Height	Load Depth	Span Load lbs/ft		Available Widths	Material*	Straight Sections & Accessories Pages	Fittings Pages
				10'	12'				
Aluminum	24A	4.120"	3.050"	181	126	6" - 36"	A	I-3 - I-4 & I-13 - I-25	L-3 - L-17
	25A	5.000"	3.930"	200	139	6" - 36"	A	I-5 - I-6 & I-13 - I-25	L-3 - L-17
	26A	6.120"	5.040"	204	142	6" - 36"	A	I-7 - I-8 & I-13 - I-25	L-3 - L-17
	27A	7.140"	6.050"	177	123	6" - 36"	A	I-9 - I-10 & I-13 - I-25	L-3 - L-17
	37A	7.140"	6.050"	—	222	6" - 36"	A	I-9 - I-10 & I-13 - I-25	L-3 - L-17
Steel	148	3.625"	3.077"	73	51	6" - 36"	S	H-3 & H-7 - H-16	H-18 - H-26
	156	4.188"	3.628"	109	76	6" - 36"	S	H-4 & H-7 - H-16	H-18 - H-26
	166	5.188"	4.628"	111	77	6" - 36"	S	H-5 & H-7 - H-16	H-18 - H-26
	176	6.188"	5.628"	124	86	6" - 36"	S	H-6 & H-7 - H-16	H-18 - H-26
	248	4.188"	3.140"	148	103	6" - 36"	S	J-3 - J-4 & J-11 - J-23	L-3 - L-17
	258	5.188"	4.140"	157	109	6" - 36"	S	J-5 - J-6 & J-11 - J-23	L-3 - L-17
	268	6.188"	5.140"	158	110	6" - 36"	S	J-7 - J-8 & J-11 - J-23	L-3 - L-17
	378	7.188"	6.140"	204	142	6" - 36"	S	J-9 - J-10 & J-11 - J-23	L-3 - L-17
Stainless Steel	348	4.188"	3.130"	180	125	6" - 36"	SS_	K-3 & K-6 - K-17	L-3 - L-17
	358	5.188"	4.130"	248	172	6" - 36"	SS_	K-4 & K-6 - K-17	L-3 - L-17
	368	6.188"	5.130"	236	164	6" - 36"	SS_	K-5 & K-6 - K-17	L-3 - L-17
Fiberglass	13F	3.000"	2.000"	93	64	6" - 24"	F	M-21 & M-45 - M-48	M-27 - M-44
	24F	4.000"	3.000"	226	157	6" - 36"	F	M-22 & M-45 - M-48	M-27 - M-44

*Material
 A = Aluminum
 S = Steel
 SS_ = Stainless Steel Type 304 or 316
 F = Fiberglass

Long 16 - 20 Foot (distance between the supports)

Recommended Intermediate Span Cable Tray Selection Use 20 ft Sections

Catalog Number	Rail Height	Load Depth	Span Load lbs/ft			Available Widths	Material*	Straight Sections & Accessories Pages	Fittings Pages
			16'	18'	20'				
H24A	4.180"	3.090"	88	70	56	6" - 36"	A	I-3 - I-4 & I-13 - I-25	L-3 - L-17
25A	5.000"	3.930"	78	62	50	6" - 36"	A	I-5 - I-6 & I-13 - I-25	L-3 - L-17
34A	4.200"	3.080"	125	99	80	6" - 36"	A	I-3 - I-4 & I-13 - I-25	L-3 - L-17
35A	5.060"	3.960"	121	96	77	6" - 36"	A	I-5 - I-6 & I-13 - I-25	L-3 - L-17
26A	6.120"	5.040"	80	63	51	6" - 36"	A	I-7 - I-8 & I-13 - I-25	L-3 - L-17
36A	6.170"	5.060"	131	104	84	6" - 36"	A	I-7 - I-8 & I-13 - I-25	L-3 - L-17
37A	7.140"	6.050"	125	99	80	6" - 36"	A	I-9 - I-10 & I-13 - I-25	L-3 - L-17
46A	6.190"	5.080"	161	127	103	6" - 36"	A	I-7 - I-8 & I-13 - I-25	L-3 - L-17
47A	7.240"	6.130"	156	123	100	6" - 36"	A	I-9 - I-10 & I-13 - I-25	L-3 - L-17
H46A	6.240"	5.090"	261	206	167	6" - 36"	A	I-7 - I-8 & I-13 - I-25	L-3 - L-17
H47A	7.240"	6.090"	233	184	149	6" - 36"	A	I-9 - I-10 & I-13 - I-25	L-3 - L-17
346	4.188"	3.130"	98	78	63	6" - 36"	S	J-3 - J-4 & HDS-11 - HDS-21	L-3 - L-17
356	5.188"	4.130"	108	85	69	6" - 36"	S	J-5 - J-6 & HDS-11 - HDS-21	L-3 - L-17
366	6.188"	5.140"	117	93	75	6" - 36"	S	J-7 - J-8 & HDS-11 - HDS-21	L-3 - L-17
378	7.188"	6.140"	80	63	51	6" - 36"	S	J-9 - J-10 & HDS-11 - HDS-21	L-3 - L-17
444	4.188"	3.110"	142	112	91	6" - 36"	S	J-3 - J-4 & HDS-11 - HDS-21	L-3 - L-17
454	5.188"	4.110"	166	131	106	6" - 36"	S	J-5 - J-6 & HDS-11 - HDS-21	L-3 - L-17
464	6.188"	5.110"	192	152	51	6" - 36"	S	J-7 - J-8 & HDS-11 - HDS-21	L-3 - L-17
476	7.188"	6.130"	120	95	77	6" - 36"	S	J-9 - J-10 & HDS-11 - HDS-21	L-3 - L-17
574	7.188"	6.110"	203	160	130	6" - 36"	S	J-9 - J-10 & HDS-11 - HDS-21	L-3 - L-17
348	4.188"	3.130"	70	56	45	6" - 36"	SS_	K-3 & K-6 - K-17	L-3 - L-17
358	5.188"	4.130"	97	77	62	6" - 36"	SS_	K-4 & K-6 - K-17	L-3 - L-17
368	6.188"	5.130"	92	73	59	6" - 36"	SS_	K-5 & K-6 - K-17	L-3 - L-17
464	6.188"	5.110"	192	152	123	6" - 36"	SS_	K-5 & K-6 - K-17	L-3 - L-17
36F	6.000"	5.000"	139	109	89	6" - 36"	F	M-23 & M-45 - M-48	M-27 - M-44
46F	6.000"	5.000"	221	174	141	6" - 36"	F	M-24 & M-45 - M-48	M-27 - M-44
H46F	6.000"	5.000"	239	188	153	6" - 36"	F	M-25 & M-45 - M-48	M-27 - M-44

*Material
 A = Aluminum
 S = Steel
 SS_ = Stainless Steel Type 304 or 316
 F = Fiberglass

**Recommended Extra Long
Span Cable Tray Selection**
Use 24 ft or 30 ft Sections
(40 ft with S8A)

Extra Long Span 24 - 30 Foot
(distance between the supports)

Cable Tray	Catalog Number	Rail Height	Span Load Depth	lbs/ft		Available Widths	Material*	Straight Sections & Accessories Pages	Fittings Pages
				24'	30'				
Aluminum	46A	6.190"	5.080"	72	-	6" - 36"	A	I-7 - I-8 & I-13 - I-25	L-3 - L-17
	47A	7.240"	6.130"	69	-	6" - 36"	A	I-9 - I-10 & I-13 - I-25	L-3 - L-17
	57A	7.400"	6.230"	161	102	12" - 36"	A	I-9 - I-10 & I-13 - I-25	L-3 - L-17
	H46A	6.240"	5.090"	116	-	6" - 36"	A	I-7 - I-8 & I-13 - I-25	L-3 - L-17
	H47A	7.240"	6.090"	103	-	6" - 36"	A	I-9 - I-10 & I-13 - I-25	L-3 - L-17
	S8A	8.000"	6.200"	252	161	12" - 36"	A	I-11 & I-12	I-12
Steel	444	4.188"	2.110"	63	-	6" - 36"	S	J-3 - J-4 & HDS-11 - HDS-21	L-3 - L-17
	454	5.188"	4.110"	74	-	6" - 36"	S	J-5 - J-6 & HDS-11 - HDS-21	L-3 - L-17
	464	6.188"	5.110"	85	-	6" - 36"	S	J-7 - J-8 & HDS-11 - HDS-21	L-3 - L-17
	476	7.188"	6.130"	53	-	6" - 36"	S	J-9 - J-10 & HDS-11 - HDS-21	L-3 - L-17
	574	7.188"	6.110"	90	-	6" - 36"	S	J-9 - J-10 & HDS-11 - HDS-21	L-3 - L-17
SS	464	6.188"	5.110"	85	-	6" - 36"	SS_	K-5 & K-6 - K-17	L-3 - L-17

*Material
 A = Aluminum
 S = Steel
 SS_ = Stainless Steel Type 304 or 316

Cable Tray Systems

Eaton's B-Line series cable trays -

Designed for Your Cable Support Requirements

Cable Tray Information

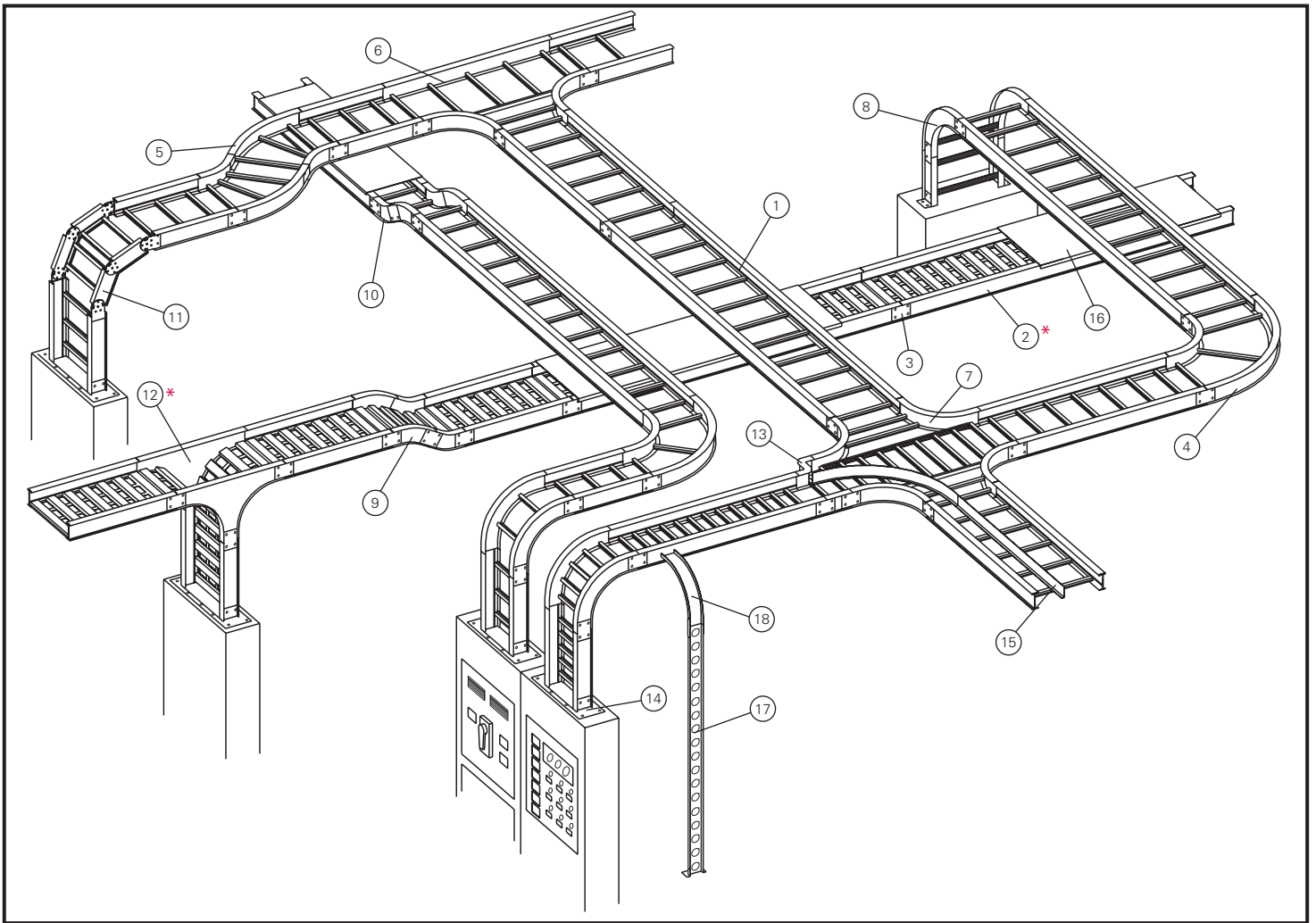

Nomenclature

- | | |
|---|--|
| ① Ladder Type Cable Tray | ⑩ 30° Vertical Inside Bend, Ladder Type Cable Tray |
| ② Ventilated Trough* Type Cable Tray | ⑪ Vertical Bend Segment (VBS) |
| ③ Straight Splice Plate | ⑫ Vertical Tee Down, Ventilated Trough* Type Cable Tray |
| ④ 90° Horizontal Bend, Ladder Type Cable Tray | ⑬ Left Hand Reducer, Ladder Type Cable Tray |
| ⑤ 45° Horizontal Bend, Ladder Type Cable Tray | ⑭ Frame Type Box Connector |
| ⑥ Horizontal Tee, Ladder Type Cable Tray | ⑮ Barrier Strip Straight Section |
| ⑦ Horizontal Cross, Ladder Type Cable Tray | ⑯ Solid Flanged Tray Cover |
| ⑧ 90° Vertical Outside Bend, Ladder Type Cable Tray | ⑰ Ventilated Channel Straight Section |
| ⑨ 45° Vertical Outside Bend, Ventilated Type Cable Tray | ⑱ Channel Cable Tray, 90° Vertical Outside Bend |

* Trough discontinued.

Finish Information

Flextray cable tray and accessories are available in a wide variety of finishes to meet the environmental or aesthetic requirements of customer installations. Use the list below to find the finish and suffix that will meet your needs.

Available product finishes will be listed on individual pages throughout the catalog.

Finish codes shown in **bold** type are the standard for that product.

Plain wire: ASTM A510, Grade 1008

- EG** Electroplated zinc galvanized finish applied after fabrication
(ELG) Recommended applications: Controlled interior
UL/CSA Classified as an equipment ground conductor when spliced as recommended
ASTM B633 - Average thickness of 0.3 mils (8 microns)
- GS** Pre-galvanized zinc finish applied before fabrication
(GLV) Recommended applications: Limited industrial & interior
UL/CSA Classified as an equipment ground conductor when spliced as recommended
ASTM A641
- BLE** Black powder coat finish applied after fabrication
Recommended applications: Controlled interior
UL/CSA Classified as an equipment ground conductor when coating has been removed at splice contact points
Average paint thickness of 1.2 mils (30 microns) to 3.0 mils (75 microns)
- HD** Hot dip galvanized finish applied after fabrication
(HDG) Recommended applications: Exterior, corrosive. Not intended for clean room applications.
UL/CSA Classified as an equipment ground conductor when spliced as recommended
ASTM A123 - Average thickness of 2.4 mils (60 microns) to 3.2 mils (80 microns)
- 304S** 304L Stainless steel
(SS4) Recommended applications: Food preparation, wash-down areas
ASTM A580
- 316S** 316L Stainless steel
(SS6) Recommended applications: Highly corrosive applications & marine environments
ASTM A580
- Custom powder coat finish applied after fabrication
Recommended applications: Controlled interior
UL/CSA Classified as an equipment ground conductor when coating has been removed at splice contact points
No Specification

Grounding Information

Statement for all UL Classified products:



This product is classified by Underwriters Laboratories, Inc. as to its suitability as an equipment grounding conductor only. 556E



Most sizes of the Flextray system are UL Classified to serve as an Equipment Ground Conductor. The ground path can be achieved in one of two ways listed on page D-4:

Grounding Information (cont.)

1. Use the recommended quantity of UL Classified splices to connect sections and at places where the tray is cut.
2. Run an appropriately sized ground wire alongside the tray and attach it to each tray section and on both sides of a cut in the tray. (This method is recommended by NEMA VE-2 Installation Manual.)

Load & Fill Chart

Flextray Series		Support Span / Loading Capacity*				Cable Fill (50% fill)**			
		Lbs/Ft (max)				Actual Area Inside Tray (in ²)	Number of CAT 5e Cables***	Number of CAT 6 Cables***	Number of CAT 6A Cables***
Part Number	Size height x width	5'-0"	6'-0"	7'-0"	8'-0"				
FT2X2	2" x 2"	34	28	24	20	4.3	61	43	33
FT2X4	2" x 4"	52	43	35	27	8.2	118	83	64
FT2X6	2" x 6"	66	47	35	27	12.1	175	123	95
FT2X8	2" x 8"	66	47	35	27	16.1	231	163	125
FT2X12	2" x 12"	68	47	35	27	23.9	345	243	187
FT2X16	2" x 16"	68	47	35	27	31.8	459	324	249
FT2X18	2" x 18"	68	47	35	27	35.8	516	364	280
FT2X20	2" x 20"	68	47	35	27	39.7	573	404	311
FT2X24	2" x 24"	68	47	35	27	47.5	686	484	372
FT2X30	2" x 30"	68	47	35	27	59.8	862	608	468
FT2X32	2" x 32"	77	53	39	30	63.3	914	645	496
FT4X4	4" x 4"	58	49	42	36	15.8	227	160	123
FT4X6	4" x 6"	93	77	60	46	23.6	341	240	185
FT4X8	4" x 8"	94	78	61	47	31.5	454	321	247
FT4X12	4" x 12"	119	83	61	47	47.5	686	484	372
FT4X16	4" x 16"	119	83	61	47	63.5	917	647	498
FT4X18	4" x 18"	119	83	61	47	71.5	1032	728	560
FT4X20	4" x 20"	119	83	61	47	79.5	1148	810	623
FT4X24	4" x 24"	128	89	65	50	95.5	1379	973	749
FT4X30	4" x 30"	128	89	65	50	119.5	1725	1217	936
FT6X8	6" x 8"	111	77	57	43	47.3	682	481	370
FT6X12	6" x 12"	124	86	63	48	71.6	1034	729	561
FT6X16	6" x 16"	128	89	65	50	95.3	1375	970	746
FT6X18	6" x 18"	128	89	65	50	107.3	1549	1092	840
FT6X20	6" x 20"	141	98	72	55	118.9	1716	1211	932
FT6X24	6" x 24"	154	107	78	60	143.3	2068	1459	1123

* Published load chart has not been tested with Flexmate™ splice. Please consult the factory for load information when using the Flexmate option.

** Flextray fill capacity is based on NEC allowable fill of 50%. The NEC rule requires that the cable cross-sectional areas together may not exceed 50% of the tray area (width x depth = fill). Cables will nearly completely fill the cable tray when reaching the 50% cable fill, due to empty space between the surface of the cables. TIA recommends 40% fill ratio. Flextray loads shown in the loading chart will not be exceeded at 50% fill.

*** CAT 5e 4-pr non-plenum approximated at .21 in. diameter, CAT 6 4-pr non-plenum approximated at .25 in. diameter, CAT 6A approximated at .285 diameter. Actual diameters vary by cable manufacturer.

Flextray wire basket - straight sections

2" Deep Flextray

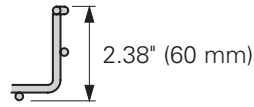
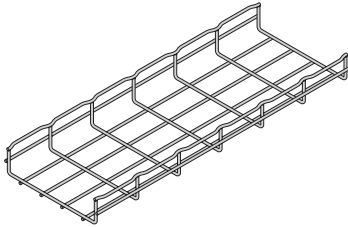

Height: 2.38" (60 mm)

Length: 118.312" (3 meter)

Wire Dia. Minimum: .196" (5.0 mm)

Finishes:

EG, BLE (GS, HD, 304S and 316S available upon request).

Part Number	Width		Wt. Per Pc.	
	in.	(mm)	lbs.	(kg)
FT2X2X10	2	(50)	6.6	(2.99)
FT2X4X10	4	(100)	8.2	(3.72)
FT2X6X10	6	(150)	9.7	(4.40)
FT2X8X10	8	(200)	11.2	(5.08)
FT2X12X10	12	(300)	14.3	(6.48)
FT2X16X10	16	(400)	17.4	(7.89)
FT2X18X10	18	(450)	18.9	(8.57)
FT2X20X10	20	(500)	20.4	(9.25)
FT2X24X10	24	(600)	23.5	(10.66)
FT2X30X10	30	(750)	28.1	(12.74)
FT2X32X10	32	(800)	29.7	(13.47)

FT2X6 (6" wide) through FT2X32 (32" wide) are UL Classified

Flextray wire basket - straight sections

4" Deep Flextray

Part Number	Width		Wt. Per Pc.	
	in.	(mm)	lbs.	(kg)
FT4X4X10	4	(100)	11.25	(5.10)
FT4X6X10	6	(150)	12.79	(5.80)
FT4X8X10	8	(200)	14.32	(6.49)
FT4X12X10	12	(300)	17.39	(7.89)
FT4X16X10	16	(400)	20.45	(9.27)
FT4X18X10	18	(450)	21.99	(9.97)
FT4X20X10	20	(500)	23.52	(10.67)
FT4X24X10	24	(600)	26.59	(12.06)
FT4X30X10	30	(750)	31.19	(14.15)

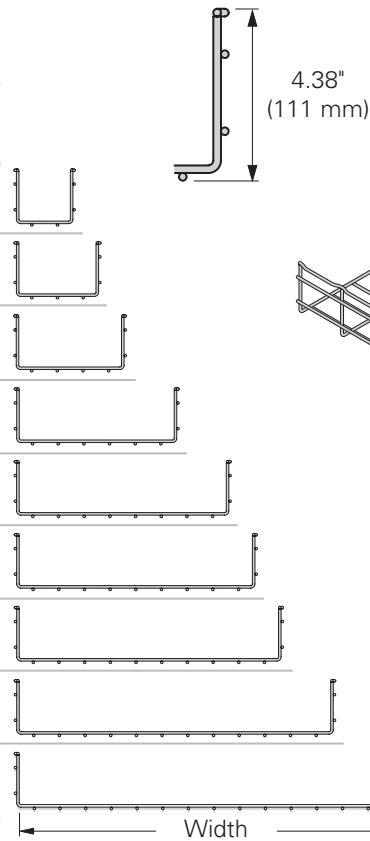

Height: 4.38" (111 mm)
Length: 118.312" (3 meter)
Wire Diameter Minimum: .196" (5.0 mm)
Finishes: EG, BLE (GS, HD, 304S and 316S available upon request).

All 4" deep Flextrays are UL Classified

6" Deep Flextray

Part Number	Width		Wt. Per Pc.	
	in.	(mm)	lbs.	(kg)
FT6X8X10	8	(200)	17.39	(7.89)
FT6X12X10	12	(300)	20.45	(9.27)
FT6X16X10	16	(400)	23.52	(10.67)
FT6X18X10	18	(450)	25.06	(11.37)
FT6X20X10	20	(500)	26.59	(12.06)
FT6X24X10	24	(600)	29.66	(13.45)

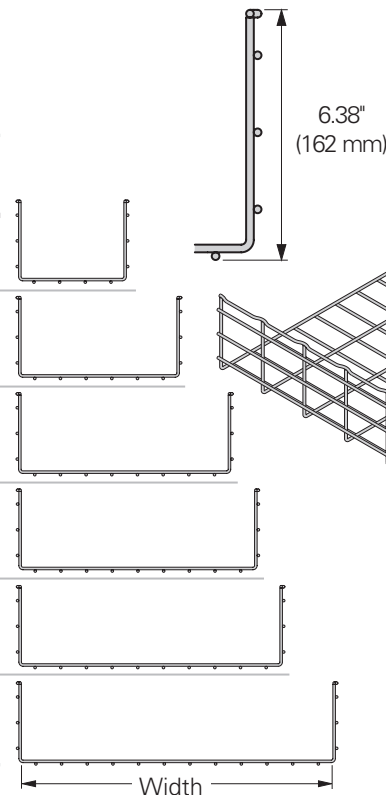

Height: 6.38" (162 mm)
Length: 118.312" (3 meter)
Wire Diameter Minimum: .196" (5.0 mm)
Finishes: EG, BLE (GS, HD, 304S and 316S available upon request).

All 6" deep Flextrays are UL Classified

See page D-3 for finish information

Washer Splice Kit

- Washer is staked to bolt, holding part stationary during installation.
- Fewer parts to handle.
- For use with all tray widths and sizes.
- Finishes __: **EG, BLE**.

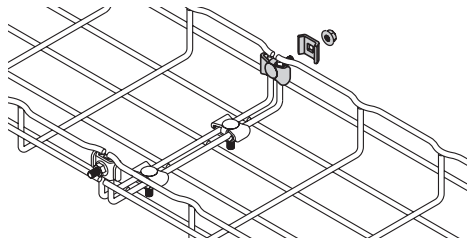

Part Number	Description	Qty./Box	Wt./Box lbs. (kg)
WASHER SPL KIT __	Assembly of Staked Washer Stud/Washer & Finned Nut	100	4.5 (2.04)

- **BLE** suffix indicates black zinc finish for this part only

Splicing Chart (number of splices required for UL Classification)

Tray Height	Tray Width - number of splices									
	2" (50mm)	4" (100mm)	6" (150mm)	8" (200mm)	12" (300mm)	16" (400mm)	18" (450mm)	20" (500mm)	24" (600mm)	>24" (>600mm)
2"	NC	NC	3	3	3	4	4	4	4	5
4"	NM	3	3	3	3	4	4	4	4	5
6"	NM	NM	3	3	3	4	4	4	4	5

NC = Not UL Classified in this size NM = Flextray is not manufactured in this size

Splice Hardware Components

- Works with all splicing needs.
- For use with all tray widths and sizes.
- Components are sold separately.
- Finishes __: **EG, BLE** (304S and 316S available upon request). **FTHDWE 1/4** not available in **BLE**.

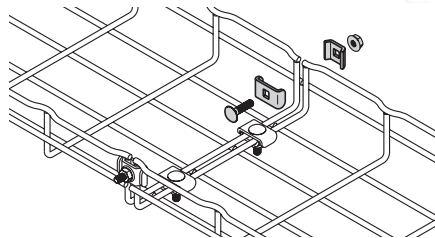

Part Number	Description	Qty./Box	Wt./Box lbs. (kg)
FTHDWE 1/4 __	1/4" x 1" Carriage Bolt & Finned nut	50	2.4 (1.08)
TOP WASHER __	1" Square Splice Washer	100	2.8 (1.26)
BTM WASHER __	1 3/16" Square Splice Washer	100	4.0 (1.82)



BTM WASHER



FTHDWE 1/4



TOP WASHER

Splicing Chart (number of splices required for UL Classification)

Tray Height	Tray Width - number of splices									
	2" (50mm)	4" (100mm)	6" (150mm)	8" (200mm)	12" (300mm)	16" (400mm)	18" (450mm)	20" (500mm)	24" (600mm)	>24" (>600mm)
2"	NC	NC	3	3	3	4	4	4	4	5
4"	NM	3	3	3	3	4	4	4	4	5
6"	NM	NM	3	3	3	4	4	4	4	5

NC = Not UL Classified in this size NM = Flextray is not manufactured in this size

See page D-3 for finish and grounding information

Connecting Hardware

Part Number	Description	Qty./Box	Wt./Box lbs. (kg)
FTSCH__	Connecting Hardware	50	2.0 (0.91)

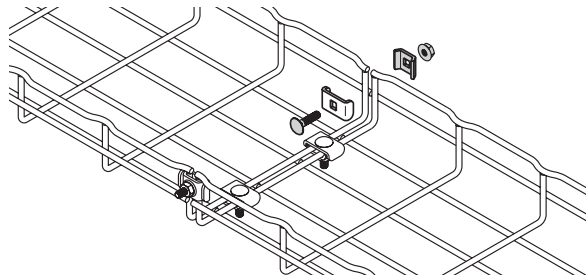

- Adaptable and designed for use with splice plate (FTS3SP), SPLICE BAR, and long splice bar (FTS36SB).
- Finishes __: **EG** (BLE-BLO, 304S and 316S available upon request).

Splicing Chart (number of splices required for UL Classification)

Tray Height	Tray Width - number of splices									
	2" (50mm)	4" (100mm)	6" (150mm)	8" (200mm)	12" (300mm)	16" (400mm)	18" (450mm)	20" (500mm)	24" (600mm)	>24" (>600mm)
2"	NC	NC	3	3	3	4	4	4	4	5
4"	NM	3	3	3	3	4	4	4	4	5
6"	NM	NM	3	3	3	4	4	4	4	5

NC = Not UL Classified in this size NM = Flextray is not manufactured in this size

Wing Splice

Part Number	Description	Qty./Box	Wt./Box lbs. (kg)
FTSWN__	Wing Splice™	50	3.0 (1.38)

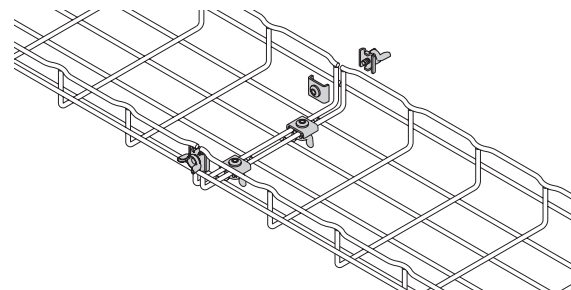

- Two piece design for easy handling.
- Tool-less installation.
- Reduces installation time, especially when used on fittings and bends.
- Finish__: **ZN**.

Splicing Chart (number of splices required for UL Classification)

Tray Height	Tray Width - number of splices									
	2" (50mm)	4" (100mm)	6" (150mm)	8" (200mm)	12" (300mm)	16" (400mm)	18" (450mm)	20" (500mm)	24" (600mm)	>24" (>600mm)
2"	NC	NC	3	3	3	4	4	4	4	5
4"	NM	3	3	3	3	4	4	4	4	5
6"	NM	NM	3	3	3	4	4	4	4	5

NC = Not UL Classified in this size NM = Flextray is not manufactured in this size

See page D-3 for finish and grounding information

Splice Plate (only)

Part Number	Description	Length in. (mm)	Height in. (mm)	Hole Diameter in. (mm)	Qty./ Box	Wt./Box lbs. (kg)
FTS3SP__	Splice Plate	2.7" (68.5)	1.6" (40.6)	0.27" (6.8)	50	6.1 (2.76)

- Splice plate is designed for use with connecting hardware (FTSCH) to provide added stability of splice connections.
- Hardware sold separately.
- Finish__: **ZN** (SS6 available upon request).
- Note: FT2x2x10 and FT2x4x10 are not UL Classified.

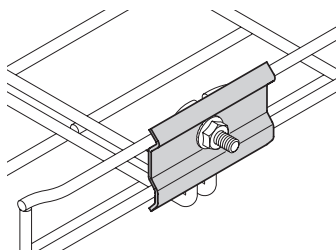

FLEXMATE Splice System

- One of the fastest splice connection methods available in the industry.
- For use with 4" (100mm) to 12" (300mm) wide tray.
- FLEXMATE clips and tool sold separately.
- Finishes __: **GS** (BLE available upon request).

Note: Tray widths larger than 12" (300mm) are not UL Classified. We recommend that splice/supports comply with NEMA VE-2 installation requirements

Part Number	Description	Qty./Box	Wt./Box lbs. (kg)
FLEXMATE2__	Flexmate Splice Clips	100	1.0 (0.45)
FLEXMATE TOOL	Flexmate Splice Tool	1	0.7 (0.32)

Flexmate Tool is used to install splices quickly.

Position clip inside tool, pointing to outside of tray.

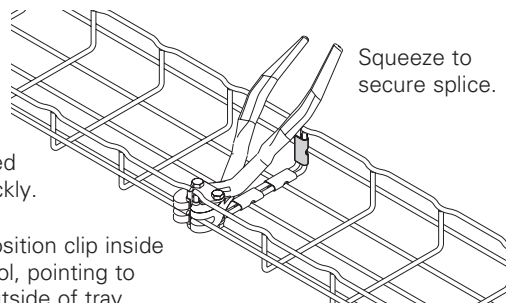

Squeeze to secure splice.



FLEXMATE2



FLEXMATE TOOL

Splicing Chart (number of splices required for UL Classification)

Tray Height	Tray Width - number of splices				
	2" (50mm)	4" (100mm)	6" (150mm)	8" (200mm)	12" (300mm)
2"	2	2	4	4	4
4"	NM	4	5	6	6
6"	NM	NM	NM	6	6

NM = Flextray is not manufactured in this size

See page D-3 for finish and grounding information

Tab-Loc Connector

Part Number	Description	Length in. (mm)	Qty./Box	Wt./Box lbs. (kg)
FTSTLC__	Tab-Loc Connectors	9.29" (235.9)	50	7.2 (3.26)

- Fast splice for straight runs of tray.
- For use with 2" (50mm) to 32" (800mm) wide tray to connect straight sections only.
- Finishes __: **ZN** (SS6 available upon request).

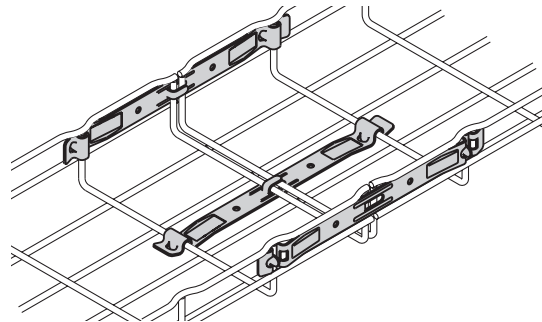

Application Requirements

The recommendations listed are equal for all depths (except as noted).

Tab-Loc security without special tools.

Screwdriver can also be used to bend tab-locs (hold connector ends while bending).

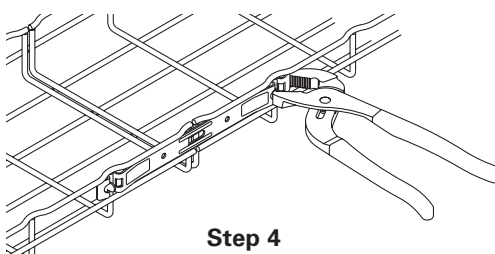
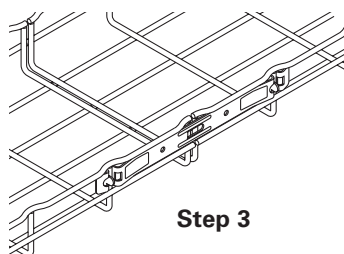
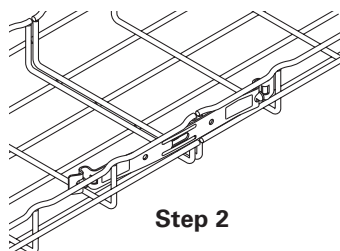
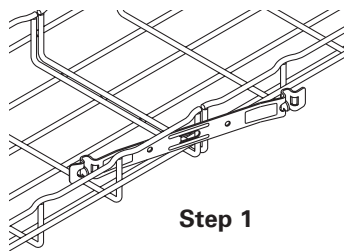

Splice Bar

- Adds rigidity to washer splice methods.
- Used on side rails only (not for use in tray bottom).
- For use on trays when using splice hardware FTSCH.
- Hardware sold separately.
- Each splice bar requires three (3) each of Hardware Splice Components - TOP WASHER, and FTHDWE 1/4 to complete connection. These items must be ordered separately.
- Washer Splice Kits (WASHER SPL KIT) are required for connections on bottom of tray.
- Finishes __: **EG**, (BLE, HD, 304S and 316S available upon request).

Part Number	Bar Length in. (mm)	Qty./Box	Wt./Box lbs. (kg)
SPLICE BAR__	10 ¹³ / ₁₆ " (274.6)	50	14.0 (6.35)

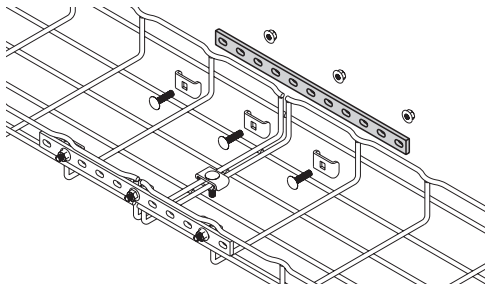

Splicing Chart (number of splices required for UL Classification)

Tray Height	Tray Width - number of splices								
	2" (50mm)	4" (100mm)	6" (150mm)	8" (200mm)	12" (300mm)	16" (400mm)	18" (450mm)	20" (500mm)	24" (600mm)
2"	NC	NC	2	2	2	2	2	2	2
4"	NM	2	2	2	2	2	2	2	2
6"	NM	NM	2	2	2	2	2	2	2

NC = Not UL Classified in this size NM = Flextray is not manufactured in this size

Splice Bar Kit

- Adds rigidity.
- Includes two (2) SPLICE BAR and hardware.
- Finishes __: **ZN** (FB and SS6 available upon request).

Part Number	Bar Length in. (mm)	Qty./Box	Wt./Box lbs. (kg)
FTSBK__	12" (304.8)	5 Sets	6.4 (2.90)

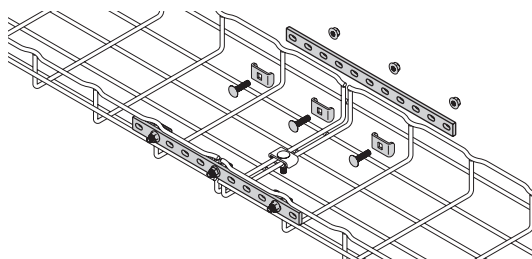

Splicing Chart (number of splices required for UL Classification)

Tray Height	Tray Width - number of splices								
	2" (50mm)	4" (100mm)	6" (150mm)	8" (200mm)	12" (300mm)	16" (400mm)	18" (450mm)	20" (500mm)	24" (600mm)
2"	NC	NC	2	2	2	2	2	2	2
4"	NM	2	2	2	2	2	2	2	2
6"	NM	NM	2	2	2	2	2	2	2

NC = Not UL Classified in this size NM = Flextray is not manufactured in this size

See page D-3 for finish and grounding information

Expansion Splice Kit

Part Number	Bar Length in. (mm)	Qty./Box	Wt./Box lbs. (kg)
FTS12ESK__	12" (304.8)	1 Kit	0.45 (0.20)

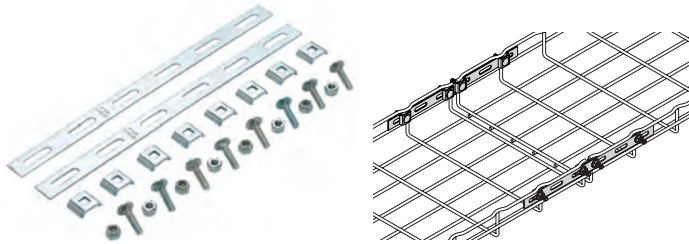

- Allows 1³/₄" (44mm) of expansion between two pieces of Flextray at expansion joints.
- To install, tighten nylon loc-nut until nut comes into contact with splice bar, then loosen approximately 1/4 turn.
- Includes two (2) splice bars and eight (8) sets of hardware.
- Finishes __: **ZN**.

Requires supports within 24" on both sides, per NEMA VE 2.

Long Splice Bar (only)

Part Number	Bar Length in. (mm)	Qty./Box	Wt./Box lbs. (kg)
FTS12SB__	12" (304.8)	1	0.13 (0.06)
FTS36SB__	36" (914.4)	1	0.40 (0.18)

- FTS36SB long splice bar is used for assembly of large radius horizontal bends or field cut into short splice bars.
- Splice Bars are designed for use with connecting hardware (FTSCH).
- Hardware sold separately.
- Finishes __: **ZN** (FB and SS6 available upon request).



FTS12SB - 6 slots



FTS36SB - 18 slots

Hold Down Plate

Part Number	Description	Box/ Qty.	Wt./Box lbs. kg
SUPT WASHER__	.28" x .70" (7.1mm x 17.8mm)	100	9.4 (4.26)
FTA6HD__	.40" x .70" (10.1mm x 17.8mm)	100	7.0 (3.17)

- Easy way to mount 4" (100mm) wide tray for raceway run.
- Use 1/4" screws to attach SUPT WASHER to your specific wall/stud application (hardware sold separately).
- FTA6HD can be used in pairs to create a center-hung support using 3/8" rod.
- To protect cables use threaded rod protector (page D-21).
- To complete 3/8" center hanger assembly use:
 - 2 - FTA6HD
 - 2 - HN 3/8"-16 hex nuts
- Finish: **ZN** (SS6 available upon request).

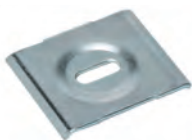

SUPT WASHER

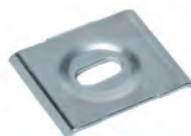

FTA6HD

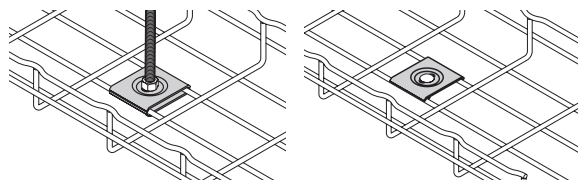

See page D-3 for finish and grounding information

- Horizontal adjustable kit can be used to create horizontal angles from prepared Flextray straight sections.
- Conveniently poly-bagged.
- Finishes ___: **EG** (BLE and 316S available upon request).

Horizontal Adjustable Kit

Part Number	Description	Qty./Box	Wt./Box lbs. (kg)
FTSHAK __	Horizontal Adjustable Kit	10	2.4 (1.09)

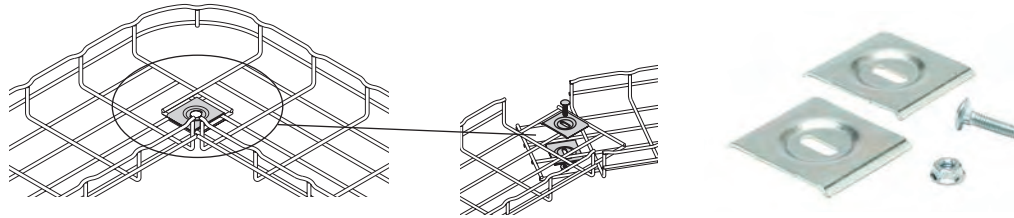

- For fast assembly of 90° turns and tee fittings.
- For use with all tray widths and sizes.
- One kit will make two 90° turns or one tee fitting.
- 90 DEGREE KIT includes: two (2) 90° splice bars and eight (8) FTSCH.
- Finishes ___: **EG** (BLE and 316S available upon request).

90 Degree Kit

Part Number	Description	Qty./Box	Wt./Box lbs. (kg)
90 DEGREE KIT __	90 degree splice bar & hardware	1	1.3 (0.59)

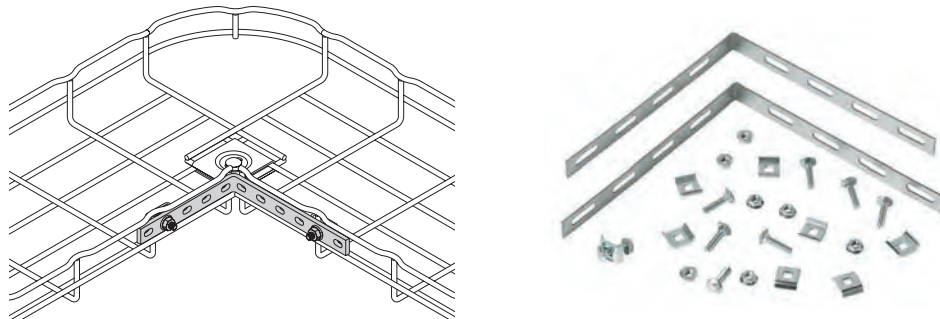

- Helps eliminate need for field fabrication and is quick to install.
- Built in tab features for positioning onto side rails at transition locations.
- For fast assembly of a 90° bend, tee, and cross fittings.
- One kit will make one 90° bend, two kits will make one tee, and four kits will make one cross fitting.
- Kit includes: one (1) corner radius and two (2) WASHER SPL KIT.
- Finishes ___: **EG** (BLE and 316S available upon request).

Corner Radius Kit

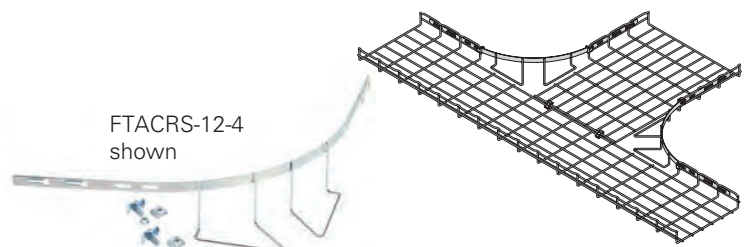
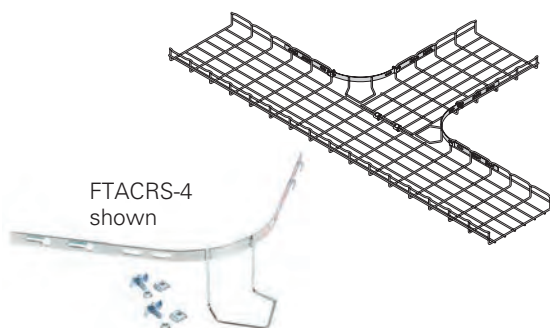

Part Number	Height in. (mm)	Radius in. (mm)	Qty. per Box	Wt./Box lbs. (kg)
FTACRS-2	2" (50.8)	6" (152.4)	1	1.3 (0.59)
FTACRS-4	4" (101.6)	6" (152.4)	1	1.3 (0.59)
FTACRS-6	6" (152.4)	6" (152.4)	1	1.3 (0.59)
FTACRS-12-2	2" (50.8)	12" (304.8)	1	1.3 (0.59)
FTACRS-12-4	4" (101.6)	12" (304.8)	1	1.3 (0.59)
FTACRS-12-6	6" (152.4)	12" (304.8)	1	1.3 (0.59)



See page D-3 for finish and grounding information

Flextray wire basket - splicing accessories

Components Required to Connect Two Sections of Flextray

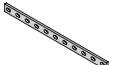
System Part Number	System Width in. (mm)	Connector Assembly WASHER SPL KIT	Connecting Hardware FTSCH	Splice Plate FTS3SP	Splice Bar SPLICE BAR
					
FT2X2 †	2" (50)	2	—	—	—
FT2X4 †	4" (100)	2	—	—	—
FT2X6	6" (150)	3 ¹	—	—	—
FT2X8	8" (200)	3 ¹	—	—	—
FT2X12	12" (300)	3 ¹	—	—	—
FT2X16	16" (400)	4 ¹	—	—	—
FT2X18	18" (450)	4 ¹	—	—	—
FT2X20	20" (500)	4 ¹	—	—	—
FT2X24	24" (600)	4 ¹	—	—	—
FT2X30	30" (750)	5 ¹	—	—	—
FT2X32	32" (800)	5 ¹	—	—	—
FT4X4	4" 100	3 ¹	—	—	—
FT4X6	6" 150	3 ¹	—	—	—
FT4X8	8" 200	3 ¹	—	—	—
FT(*)X12	12" 300	3 ¹	—	—	—
FT(*)X16	16" 400	4 ¹	—	—	—
FT(*)X18	18" (450)	4 ¹	—	—	—
FT(*)X20	20" 500	4 ¹	—	—	—
FT(*)X24	24" 600	4 ¹	—	—	—
FT(*)X30	30" (750)	5 ¹	—	—	—
FT2X2 †	2" (50)	—	2	2	—
FT2X4 †	4" (100)	—	2	2	—
FT2X6	6" (150)	1	2	2	—
FT2X8	8" (200)	1	2	2	—
FT2X12	12" (300)	1	2	2	—
FT2X16	16" (400)	2	2	2	—
FT2X18	18" (450)	2	2	2	—
FT2X20	20" (500)	2	2	2	—
FT2X24	24" (600)	2	2	2	—
FT2X30	30" (750)	3	2	2	—
FT2X32	32" (800)	3	2	2	—
FT4X4	4" (100)	1	2	2	—
FT4X6	6" (150)	1	2	2	—
FT4X8	8" (200)	1	2	2	—
FT(*)X12	12" (300)	1	2	2	—
FT(*)X16	16" (400)	2	2	2	—
FT(*)X18	18" (450)	2	2	2	—
FT(*)X20	20" (500)	2	2	2	—
FT(*)X24	24" (600)	2	2	2	—
FT(*)X30	30" (750)	3	2	2	—
FT2X2 †	2" (50)	—	6	—	2
FT2X4 †	4" (100)	—	6	—	2
FT2X6	6" (150)	1	6	—	2
FT2X8	8" (200)	1	6	—	2
FT2X12	12" (300)	1	6	—	2
FT2X16	16" (400)	2	6	—	2
FT2X18	18" (450)	2	6	—	2
FT2X20	20" (500)	2	6	—	2
FT2X24	24" (600)	2	6	—	2
FT2X30	30" (750)	3	6	—	2
FT2X32	32" 800	3	6	—	2
FT4X4	4" (100)	1	6	—	2
FT4X6	6" (150)	1	6	—	2
FT4X8	8" (200)	1	6	—	2
FT(*)X12	12" (300)	1	6	—	2
FT(*)X16	16" (400)	2	6	—	2
FT(*)X18	18" (450)	2	6	—	2
FT(*)X20	20" (500)	2	6	—	2
FT(*)X24	24" (600)	2	6	—	2
FT(*)X30	30" (750)	3	6	—	2

(*) 4 for 4" Deep Flextray
6 for 6" Deep Flextray

Washer Splice Kits

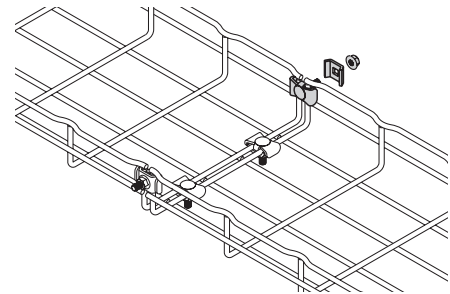

¹ Install one kit on each side and remaining kit(s) on bottom.

Splice Plates

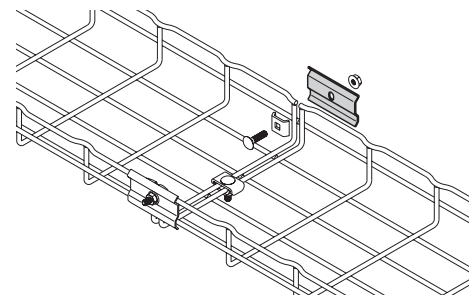

Install splice plates on sides and WASHER SPL KIT on bottom.

Splice Bars

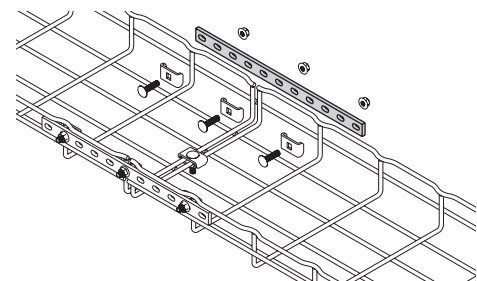

Install splice bars on sides and WASHER SPL KIT on bottom.

† Sizes not UL Classified

Splice Plate Kits for 2" Deep Flextray

Part Number	System Width		Weight Per 100		Box Quantity	Conveniently poly-bagged for use with 2" Deep Flextray			
	in.	(mm)	lbs.	(kg)					
FTS20SK	2"	(50)	2.91	(1.32)	10				
	4"	(100)							
FTS21SK	6"	(150)	3.63	(1.64)	10				
	8"	(200)							
	12"	(300)							
FTS22SK	16"	(300)	4.35	(1.97)	10				
	18"	(450)							
	20"	(500)							
	24"	(600)							
FTS23SK	30"	(750)	5.07	(2.30)	10				
	32"	(800)							

Splice Plate Kits for 4" & 6" Deep Flextray

Part Number	System Width		Weight Per 100		Box Quantity	Conveniently poly-bagged for use with 4" & 6" Deep Flextray			
	in.	(mm)	lbs.	(kg)					
FTS21SK	4"	(100)	3.63	(1.64)	10				
	6"	(150)							
	8"	(200)							
	12"	(300)							
FTS22SK	16"	(400)	4.35	(1.97)	10				
	18"	(450)							
	20"	(500)							
	24"	(600)							
FTS23SK	30"	(750)	5.07	(2.30)	10				

Flip Clip™

- Accommodates 1/4" and 3/8" rod sizes.
- Installs quickly with a screwdriver or pliers thus reducing installation time.
- Requires only one hex nut (not included) to hang and level the Flextray.
- Retainer tabs can be bent over to lock-in the threaded rod and wire basket.
- Finishes __: **ZN** (FB and SS6 available upon request).

Part Number	Description	Qty./Box	Wt./Box lbs. (kg)
WB46H__	Flip Clip™	50	5.2 (2.36)

Snap retainer stops in place after cable is loaded.

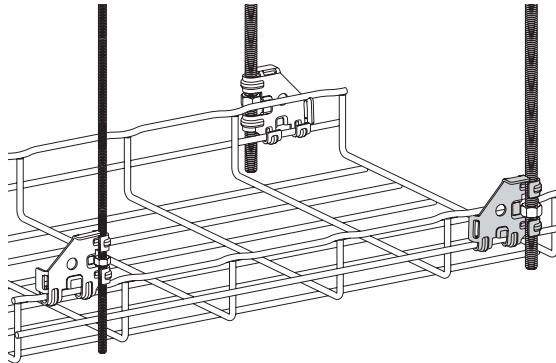

Trapeze Support

- Trapeze Clip installs fast.
- For use with trays up to 4" (100mm) deep, 12" (300mm) wide, and spans up to 8'-0" (2.44m).
- Tray can be released from support to allow side cable loading.
- Accepts 1/4" and 3/8" threaded rod sizes.
- Finishes __: **GS** (BLE available upon request).

Part Number	Description	Qty./Box	Wt./Box lbs. (kg)
TRAPEZE SUPT2__	Trapeze Support Clip	50 trapeze clips 100 retainer stops	7.0 (3.17)

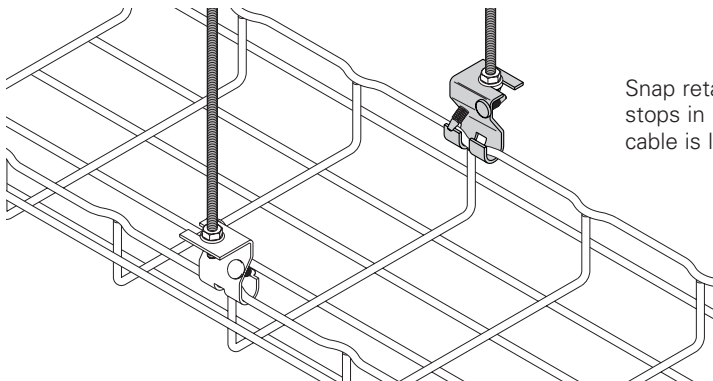

Snap retainer stops in place after cable is loaded.



See page D-3 for finish information

Wire basket - ceiling support methods

2" Center Hanger

Part Number	Description	Qty./Box	Wt./Box lbs. (kg)
2 IN CTR SUPT__	Center Support Hanger for FT2x2	50	5.0 (2.27)

- For use with 2" (50mm) tray widths only.
- Accepts 1/4" threaded rod.
- Hardware sold separately.
- Assemble with ATTACHMENT CLP & FTHDWE 1/4 hardware.
- Finishes __: **GS** (BLE available upon request).

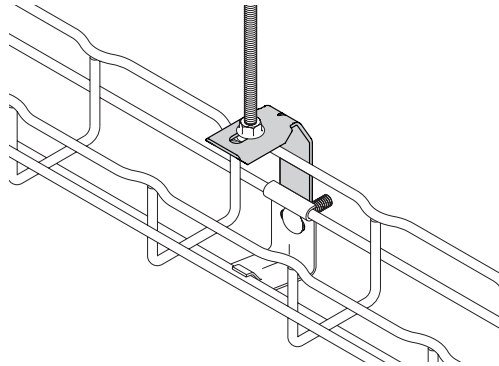

Hold Down Plate

Part Number	Description	Qty./Box	Wt./Box lbs. (kg)
SUPT WASHER__	.28" x .70" (7.1mm x 17.8mm)	100	9.4 (4.26)
FTA6HD__	.40" x .70" (10.1mm x 17.8mm)	100	7.0 (3.18)

- Easy way to mount 4" (100mm) wide tray for raceway run.
- Use 1/4" screws to attach SUPT WASHER to your specific wall/stud application (hardware sold separately).
- FTA6HD can be used in pairs to create a center-hung support using 3/8" rod.
- To protect cables use threaded rod protector (page D-20).
- To complete 3/8" center hanger assembly use:
2 - FTA6HD
2 - HN 3/8"-16 hex nuts
- Finish: **ZN** (SS6 available upon request).

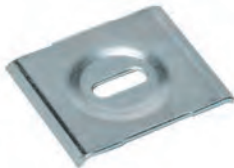

SUPT WASHER

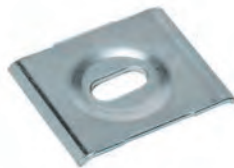

FTA6HD

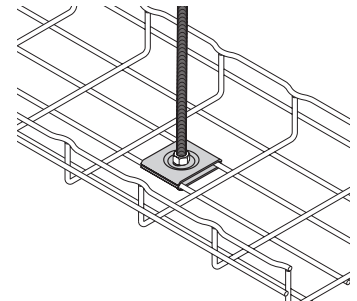
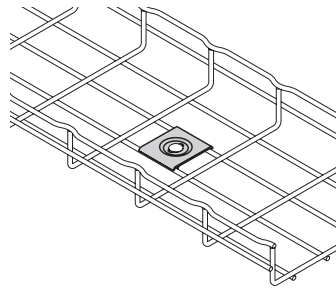

Mounting Bracket

- Designed to support FT2X2X10 Flextray.
- Click tabs for Flextray attachment.
- Use 1/4" hardware and washer (not included) to mount bracket.
- Finishes __: **SS6**.

Part Number	Description	Qty./Box	Wt./Box lbs. (kg)
FTB2UB__	Light Duty Wall/Rack Bracket	10	2.1 (0.95)

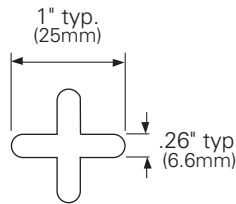
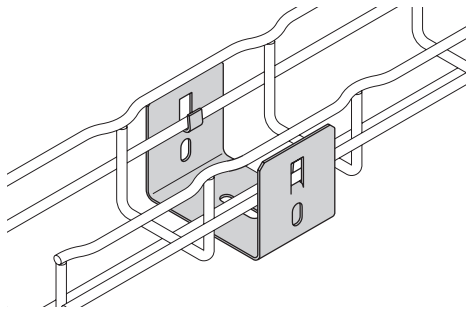

- Use for light duty cabling applications.
- For use with 1 1/2" (38mm) & 2" (51mm) deep tray with 4" (100mm) and 6" (150mm) widths.
- When hanging 4" (100mm) wide tray, center hung clip must be run parallel with the tray.
- Built-in hold down tab.
- Accepts 1/4" threaded rod.
- Threaded rod and nuts sold separately.
- Finishes __: **GS** (BLE available upon request).

Center Hung Clip

Part Number	Description	Qty./Box	Wt./Box lbs. (kg)
CTR HUNG CLP__	Light Duty Center Hanger	50	4.0 (1.81)

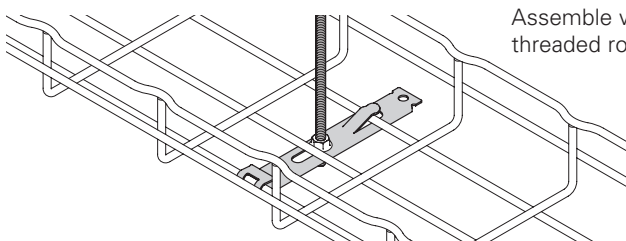

Assemble with 1/4" threaded rod and finned nut



- Use to protect cables from 1/4" to 1/2" threaded rod.
- PVC UL94V-O material.
- Color: Gray.
- Not plenum rated.

Threaded Rod Protector

Part Number	Description	Qty./Box	Wt./Box lbs. (kg)
SB301-1/2x8	Rod Protector	1	0.03 (0.013)

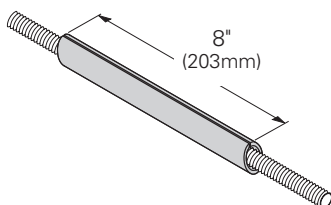

See page D-3 for finish information

Wire basket - ceiling support methods

Center Trapeze Hanger

- Can be installed as center-hung or traditional trapeze hanger.
- Multiple options to secure Flextray to hanger.
 - Built in hold down tabs (use screwdriver to bend down tab).
 - Compatible with TOOLLESS CLIP with snap-inlocking pin.
 - Compatible with WBUHD hold down clip when tray crosswire is aligned over top of hanger.
 - Slots and holes for optional hardware attachment.
- Corrosion resistant pre-galvanized zinc finish (other finishes available upon request).
- Center hole for up to 1/2" rod.
- Hole on each end for up to 3/8" rod.
- Threaded rod protector available (SB301-1/2 x 8) see page D-20.
- When 1/2" trapeze rods are required, add -1/2 to end of part number when ordering.

Part Number	Maximum Tray Width		Actual Length		Wt./Pc.	
	in.	(mm)	in.	(mm)	lbs.	(kg)
FTB06CT	6"	(150)	9.78"	(248)	0.61	(0.27)
FTB08CT	8"	(200)	11.75"	(298)	0.74	(0.33)
FTB12CT	12"	(300)	15.69"	(398)	0.98	(0.44)
FTB16CT	16"	(400)	19.63"	(498)	1.61	(0.73)
FTB18CT	18"	(450)	21.59"	(548)	1.77	(0.80)
FTB20CT	20"	(500)	23.56"	(598)	1.93	(0.87)
FTB24CT	24"	(600)	27.50"	(698)	2.25	(1.02)

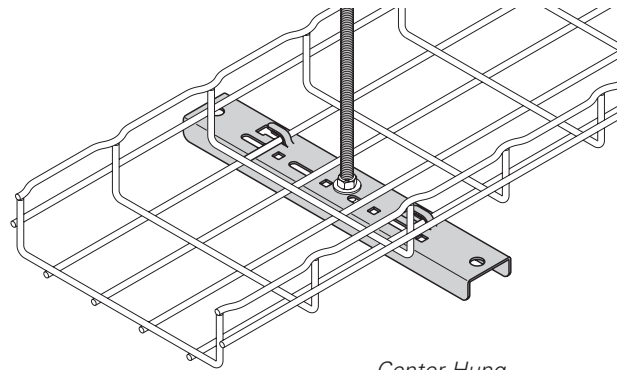

Center Hung

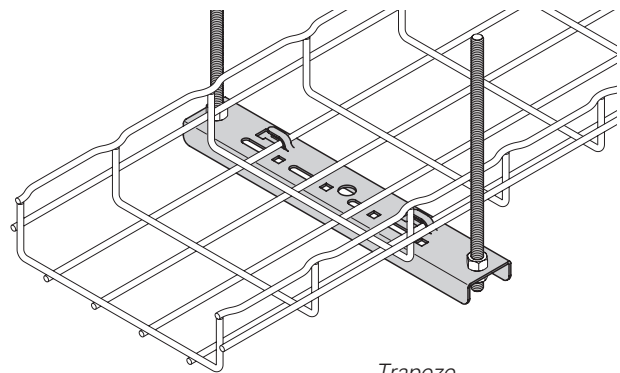

Trapeze

See page D-3 for finish information

KwikWire Clamps & Wire Rope

- KwikWire™ system replaces jack chain or ATR to support lighting, ductwork, and Flextray.
- Can be quickly installed around beams - No drilling required.
- Ideal for sloped ceilings - can hang objects at up to 60° angles.
- Simple height adjustments are made by releasing locking tab, no tools required.
- Spools of wire can be cut to length in field, reducing waste and up front planning.

Part No.	Clamps - For Use With Wire Rope Diameters	Box Qty.
BKC100	1/16" (1.6mm) & 3/32" (2.3mm)	100
BKC200-1	1/8" (3.2mm) & 3/16" (4.7mm)	50



Part No.	Rope Dia.		Working Load		Spool
	in.	(mm)	Lbs.	(kg)	
BKW063 ⁽¹⁾	1/16"	(1.6)	96	(43.5)	500 ft.
BKW094 ⁽¹⁾	3/32"	(2.3)	184	(83.4)	500 ft.
BKW125 ⁽¹⁾	1/8"	(3.2)	340	(154.2)	500 ft.
BKW188 ⁽²⁾	3/16"	(4.8)	840	(381.0)	250 ft.



Wire Rope Construction

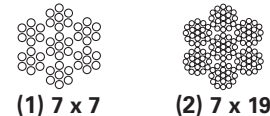

KwikWire Clamp Working Loads*

Clamp Part No.	Wire Rope Dia.	Lbs. Safety Factor 4
BKC100	1/16"	0-75
BKC100	3/32"	25-150
BKC200-1	1/8"	25-250
BKC200-1	3/16"	50-500

* Working loads shown are for hanging vertically. For suspending at 15°, 30°, 45° or 60° angles from vertical, use the following percentage of the working loads from the chart:

15° = 96%
 30° = 86%
 45° = 70%
 60° = 50%

Cutter Part No.	Box Qty.
BKCC	1



- KwikPak™ includes a supply of kwik-clamps and a spool of wire rope.
- KwikPak are shipped in a specially designed dispenser box to ease field cutting of wire.

Part No.	For Use With Wire Rope Diameters	Box Qty.
BKP10063	BKC100 (100 pcs.) 1/16" Ø Wire Rope (500 ft.)	1
BKP10094	BKC100 (100 pcs.) 3/32" Ø Wire Rope (500 ft.)	1
BKP20125	BKC200-1 (50 pcs.) 1/8" Ø Wire Rope (500 ft.)	1
BKP20188	BKC200-1 (50 pcs.) 3/16" Ø Wire Rope (250 ft.)	1



KwikPak Wire Rope & Clamps

See page D-3 for finish information

Wire basket - ceiling support methods

KwikWire Accessory Features

- Helps reduce on the job installation time.
- Can be installed quickly without drilling into existing structure.
- Increases versatility in the field.
- KwikWire accessory system helps reduce inventory and shipping costs.
- No more sawing, filing, or fixing nuts.
- Designed for use with cable tray, lighting, and HVAC.
- Eliminates the need for all threaded rod.
- Cost effective solution for jack chain.
- "Y" style accessories require 50% less drilling.



KwikWire Accessory Numbering System

Product Line	Assembly Configuration	Leg Termination	Leg Length	Wire Rope Diameter	Straight Length	Assembly or Kit
BK = KwikWire	Blank = Single Leg Y = 2 Legs 3 - 3 Legs	A = Angle Bracket w/Pin H = Hook L = Loop T = Toggle W = Fuse Cut B25 = Bolt w/ 1/4"-20 Thread B38 = Bolt w/ 3/8"-16 Thread BM6 = Bolt w/ M6 Thread BM8 = Bolt w/ M8 Thread BM10 = Bolt w/ M10 Thread	Blank = See Straight Length 18 = 18" Leg 30 = 30" Leg	063 = 1/16" 094 = 3/32"	Blank = Loop w/ Plastic Tube 18 = 18" 30 = 30" 40 = 40" 80 = 80" 120 = 120" 180 = 180" 240 = 240" 360 = 360"	Blank = Assembly Only K = Kit (Assembly & BKC100 Clamp)

Examples

BKYT18-094-120K



KwikWire Accessory

2 legs - toggle leg termination - 18" legs - 1/16" diameter wire - 120" straight length - kit with clamp

BKL-063-120K



KwikWire Accessory

single leg - looped leg termination - 1/16" diameter wire - 120" straight length - kit with clamp

See page D-3 for finish information

KwikWire 'Y' Style Hook Termination

Part No.	Leg Length		Wire Rope Dia.		Length	
	in.	(mm)	in.	(mm)	in.	(mm)
BKYH18-094-40	18"	(457)	$\frac{3}{32}$ "	(2.3)	40"	(1016)
BKYH18-094-80	18"	(457)	$\frac{3}{32}$ "	(2.3)	80"	(2032)
BKYH18-094-120	18"	(457)	$\frac{3}{32}$ "	(2.3)	120"	(3048)
BKYH18-094-180	18"	(457)	$\frac{3}{32}$ "	(2.3)	180"	(4572)
BKYH18-094-240	18"	(457)	$\frac{3}{32}$ "	(2.3)	240"	(6096)
BKYH18-094-360	18"	(457)	$\frac{3}{32}$ "	(2.3)	360"	(9144)
BKYH30-094-40	30"	(762)	$\frac{3}{32}$ "	(2.3)	40"	(1016)
BKYH30-094-80	30"	(762)	$\frac{3}{32}$ "	(2.3)	80"	(2032)
BKYH30-094-120	30"	(762)	$\frac{3}{32}$ "	(2.3)	120"	(3048)
BKYH30-094-180	30"	(762)	$\frac{3}{32}$ "	(2.3)	180"	(4572)
BKYH30-094-240	30"	(762)	$\frac{3}{32}$ "	(2.3)	240"	(6096)
BKYH30-094-360	30"	(762)	$\frac{3}{32}$ "	(2.3)	360"	(9144)



Box Quantity - 10
5 bags containing 2 pieces per bag

KwikWire 'Y' Style Hook Termination With Loop

Part No.	Wire Rope Dia.		Length	
	in.	(mm)	in.	(mm)
BKYH18-094	$\frac{3}{32}$ "	(2.3)	18"	(457)
BKYH30-094	$\frac{3}{32}$ "	(2.3)	30"	(762)

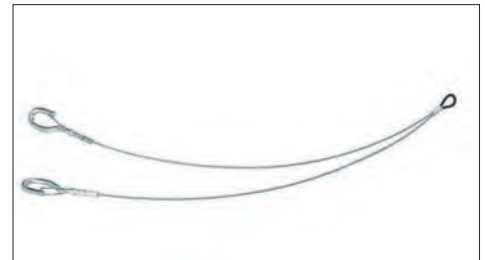

Box Quantity - 10
5 bags containing 2 pieces per bag

- Hook designed for up to $\frac{3}{8}$ " diameter wire.
- Available as a wire rope with hook termination only or as a ready-to-use kit with a BKC100 clamp.
- Available in lengths of 40", 80", 120", 180", 240", and 360".
- Available in single, double (Y), and triple (3) leg styles.

For more information on KwikWire accessories see the KwikWire catalog.

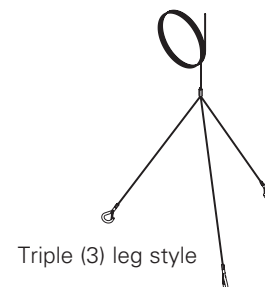

See page D-3 for finish information

Shelf Brackets

- Heavy-duty support bracket.
- For use with 6" (150mm) to 24" (600mm) wide trays.
- Built-in tab for hold down.
- Optional hardware (FTSCH) sold separately.
- Finishes __: **GLV** (HDG and SS6 available upon request).

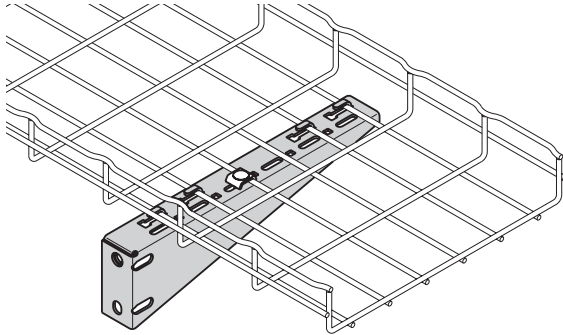

Part Number	Use With Tray Width		Qty./Box	Wt./Pc. lbs. (kg)
	in.	(mm)		
FTB06CS __	6"	(150)	1	0.5 (0.22)
FTB08CS __	8"	(200)	1	0.6 (0.27)
FTB12CS __	12"	(300)	1	1.2 (0.54)
FTB16CS __	16"	(400)	1	1.7 (0.77)
FTB18CS __	18"	(450)	1	1.9 (0.86)
FTB20CS __	20"	(500)	1	2.6 (1.18)
FTB24CS __	24"	(600)	1	3.2 (1.45)



L Brackets

- Installs tray to wall cleanly.
- Built-in tab for hold down (not available in stainless steel).
- For use with 4" (100mm) to 24" (600mm) wide trays.
- Use with pedestal clamp in raised floor applications.
- Optional hardware (FTSCH) sold separately.
- Finishes __: **EG** (HD, BLE and 316S available upon request).

Part Number	Use With Tray Width		Qty./Box	Wt./Pc. lbs. (kg)
	in.	(mm)		
4 L BRKT __	4"	(150)	1	0.6 (0.27)
8 L BRKT __	6"	(150)	1	0.8 (0.36)
	8"	(200)		
12 L BRKT __	12"	(300)	1	1.3 (0.59)
16 L BRKT __	16"	(400)	1	1.4 (0.63)
	18"	(450)		
20 L BRKT __	20"	(500)	1	2.0 (0.91)
	24"	(600)		
24 L BRKT __	24"	(600)	1	2.3 (1.04)

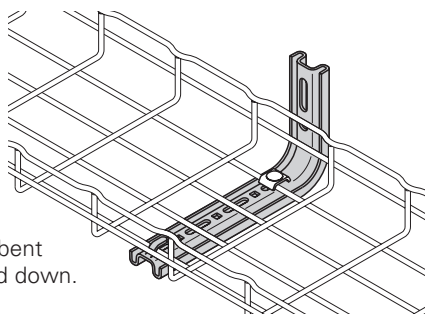

Tab can be bent over for hold down.



12 L BRKT

See page D-3 for finish information

Flextray wire basket - wall support methods

Z Brackets

Part Number	Description	Qty./Box	Wt./Box lbs. (kg)
Z BRKT__	Z Bracket	25	14.0 (6.35)

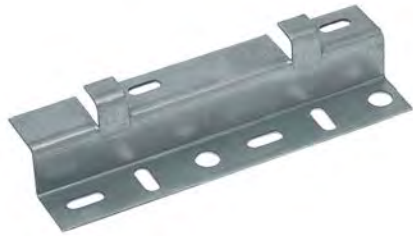

- Used for horizontal and/or vertical mounting.
- 8" (200mm) wide bracket for use with 4" (100mm) to 32" (800mm) wide trays.
- Can be used to offset trays from floor.
- Can be used to terminate tray run at wall.
- Multiple brackets can be used for wider tray widths.
- Use with two (2) FTSCB (sold separately).
- Finishes __: **GS** (BLE available upon request).

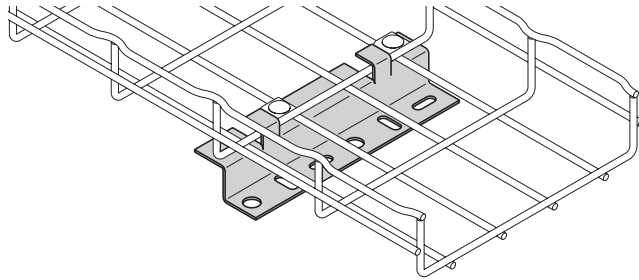

Hold Down Plate

Part Number	Description	Qty./Box	Wt./Box lbs. (kg)
SUPT WASHER__	.28" x .70" (7.1mm x 17.8mm)	50	4.7 (2.13)
FTA6HD__	.40" x .70" (10.1mm x 17.8mm)	50	3.5 (1.59)

- Easy way to mount 4" (100mm) wide tray for raceway run.
- Use 1/4" screws to attach SUPT WASHER to your specific wall/stud application (hardware sold separately).
- FTA6HD can be used in pairs to create a center-hung support using 3/8" rod.
- To protect cables use threaded rod protector (page D-20).
- To complete 3/8" center hanger assembly use:
 - 2 - FTA6HD
 - 2 - HN 3/8"-16 hex nuts
- Finish: **ZN** (SS6 available upon request).

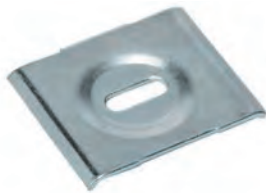

SUPT WASHER

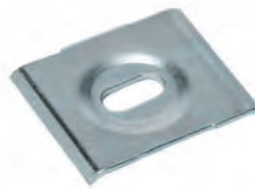

FTA6HD

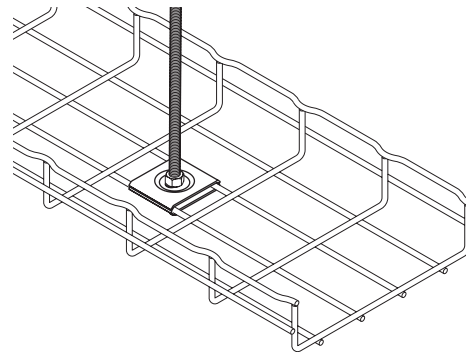
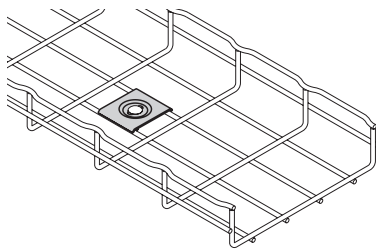

Attachment Clips

- Wall attachment for 2" (50mm) wide tray only (FT2X2X10).
- Low-profile appearance.
- Built-in tab to hold down tray.
- Can also be used with 2" (50mm) Center Hanger (see page D-19).
- Hardware sold separately.
- Finishes __: **GS** (BLE available upon request).

Part Number	Description	Qty./Box	Wt./Box lbs. (kg)
ATTACHMENT CLP__	Support for FT2x2x10	50	3.4 (1.54)

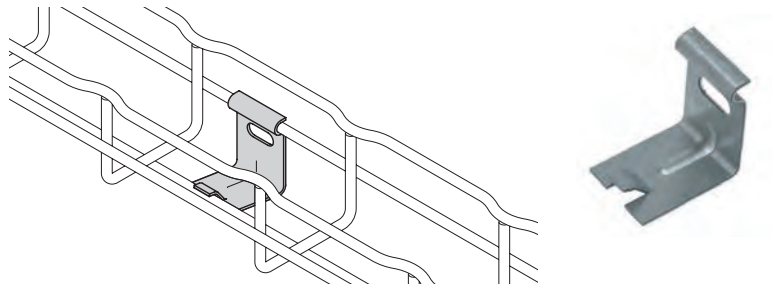

Mounting Bracket

- Designed to support FT2X2X10 Flextray.
- Click tabs for Flextray attachment.
- Use 1/4" hardware and washer (not included) to mount bracket.
- Finishes __: **SS6**.

Part Number	Description	Qty./Box	Wt./Box lbs. (kg)
FTB2UB__	Light Duty Wall/Rack Bracket	10	2.1 (0.95)

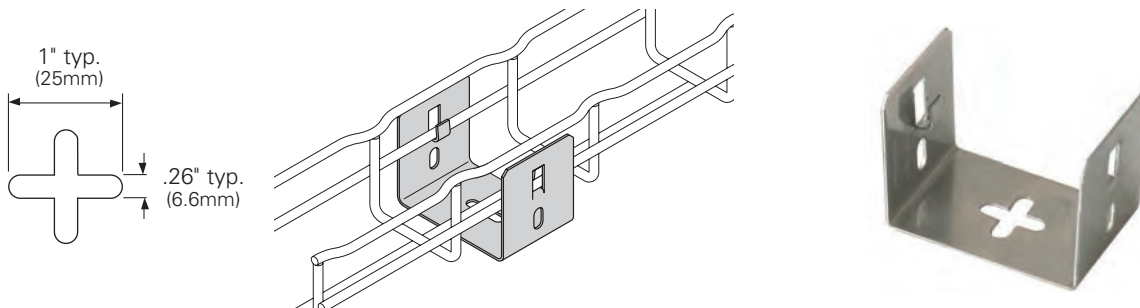

Wall Supports

- Used to attach 2" (50mm) or 4" (100mm) wide trays to walls, struts or cabinets.
- Use for raceway mounting.
- Mount to metal framing for vertical support.
- Tabs are built in for tray hold down.
- Mount to side rail for electrical box connection.
- Finishes __: **GLV**.

Part Number	Description	Qty./Box	Wt./Box lbs. (kg)
FTA050CC__	Wall Support Bracket	1	0.8 (0.36)

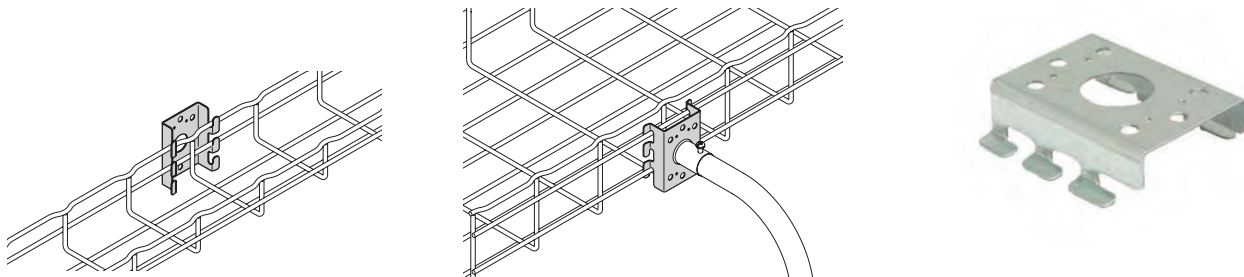

See page D-3 for finish information

Wall Termination Kit

Part Number	Length		Qty./Box	Wt./Box	
	in.	(mm)		lbs.	(kg)
FTA9WTK__	9"	(228.6)	1	1.3	(0.59)

- Kit includes all hardware necessary to support Flextray when terminated at a wall.
- Mount slotted angle to wall with up to $\frac{3}{8}$ " hardware (not included).
- Wall Termination Kit includes:
 - 1 - Angle with Slots
 - 2 - FTSCH
- Finishes __: **ZN** (FB and SS6 available upon request).

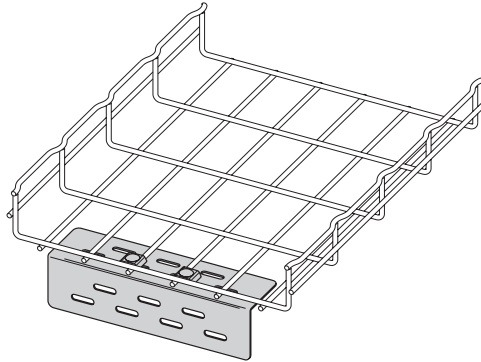

Wall Mount Kit

Part Number	Length		Qty./Box	Wt./Box	
	in.	(mm)		lbs.	(kg)
WB48WMK__	8"	(203.2)	1	0.76	(0.35)
WB1224WMK__	12"	(304.8)	1	1.22	(0.55)

- Kit includes all components necessary to mount Flextray to a wall horizontally or vertically
- Mount strut to wall with up to $\frac{1}{2}$ " hardware (not included).
- Wall Mount Kit includes:

WB48WMK	WB1224WMK	
1	1	B54SH Strut
1	2	SUPT WASHER Hold Downs
1	2	$\frac{1}{4}$ "-20 x 1" Slotted Head Screw
1	2	N224WO Channel Nut
- Finish: Channel - **GLV**; Hardware - **ZN**; (SS6 available upon request)



WB1224WMK shown

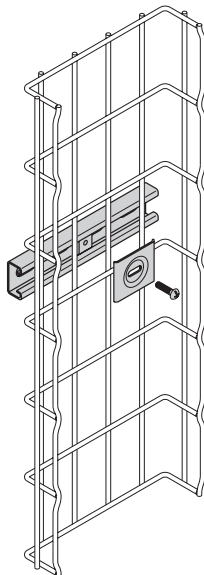

Vertically Mounted

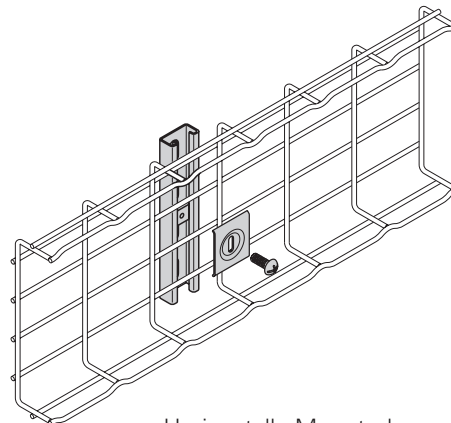

Horizontally Mounted

See page D-3 for finish information

C Brackets

- Tab can be used for hold down (stainless steel will not have these tabs)
- For use with 4" (100mm) to 12" (300mm) wide trays
- C bracket attaches to hard ceiling types
- All brackets are 7-7/8" (200mm) tall
- Cables can be side loaded
- L brackets (page D-26) and C brackets can be combined for layered tray runs
- Finishes __: **EG** (BLE and HD available upon request)

Part Number	Tray Width - Up To in. (mm)	Qty./Box	Wt./Box lbs. (kg)
4 C BRKT__	4" (100)	1	1.2 (0.54)
8 C BRKT__	8" (200)	1	1.4 (0.63)
12 C BRKT__	12" (300)	1	1.9 (0.86)

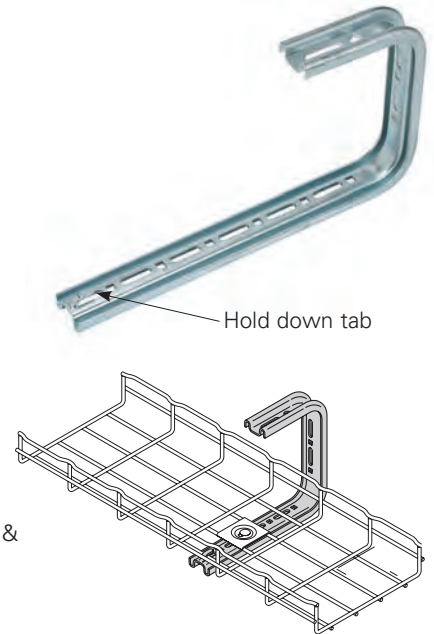
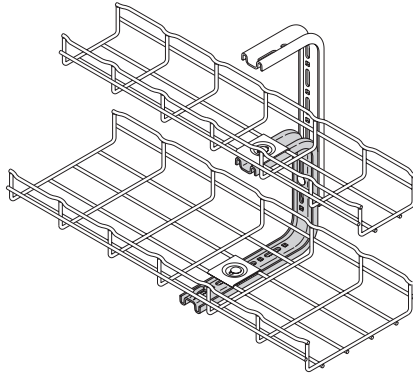
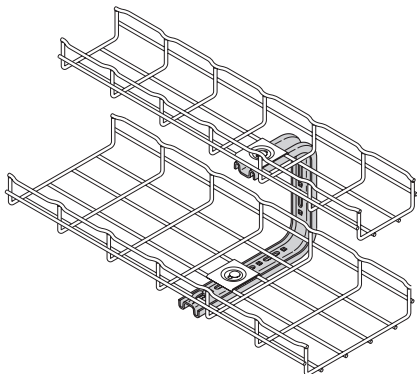

Assemble with
SUPT WASHER &
FTHDWE 1/4"

- Under floor support bracket provides rugged support for FLEXTRAY System from access floor post.
- To complete the installation, the following hardware must be ordered separately.
 - (2) - B501 U-Bolts
 - (1) - SUPT WASHER Hold Down
 - (1) - 1/4"-20 x 1" Slotted Head Screw
 - (1) - N224WO Channel Nut
- Finish: **ZN**

Under floor support bracket

Part Number	'A' in. (mm)	Box Quantity	Wt. Per Each lbs. (kg)
B409UF-12	12" (300)	1	3.6 (1.63)
B409UF-18	18" (450)	1	4.5 (2.04)
B409UF-21	21" (533)	1	5.4 (2.45)

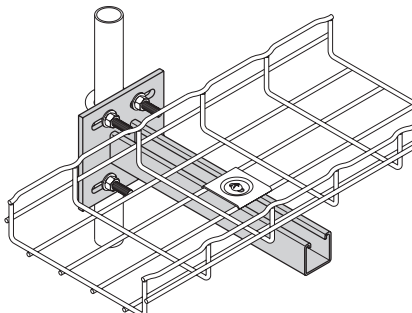
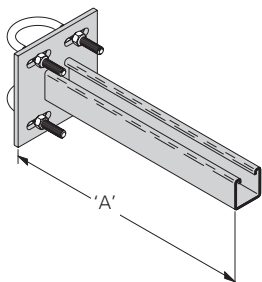

See page D-3 for finish information

Covers

- Protects cable from debris and dust
- Adds security to cable installation
- Easy bend-over tabs secure cover to trays
- Available for 2" (50mm) to 24" (600mm) wide trays
- Comes in 118" (2997mm) length
- Finishes __: **GS** (BLE, 304S and 316S available upon request)

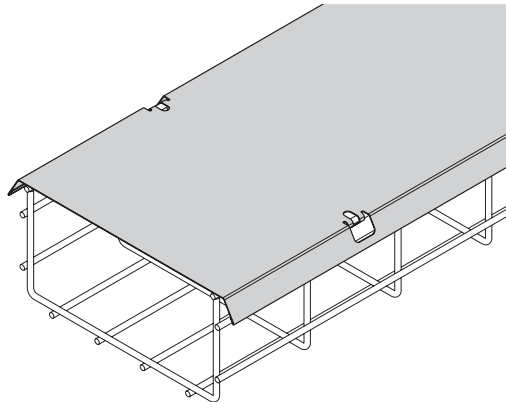

Part Number	For Tray Width Of in. (mm)	Qty./Box	Wt./Box lbs. (kg)
2 IN COVER __	2" (50)	1	3.8 (1.72)
4 IN COVER __	4" (100)	1	5.7 (2.58)
6 IN COVER __	6" (150)	1	6.7 (3.04)
8 IN COVER __	8" (200)	1	8.7 (3.94)
12 IN COVER __	12" (300)	1	11.6 (5.26)
16 IN COVER __	16" (400)	1	15.6 (7.07)
18 IN COVER __	18" (450)	1	17.0 (7.71)
20 IN COVER __	20" (500)	1	18.5 (8.39)
24 IN COVER __	24" (600)	1	22.0 (9.98)



Dividers

- Allows cable separation within a single tray
- Hemmed, rounded edge provides cable jacket safety
- Hardware included (see image below)
- Field miter for bends and turns
- Dual slots every 24" (609mm) for field cutting
- Available in 2" (50mm), 4" (100mm) and 6" (150mm) heights
- Comes in 118.125" (3000mm) length
- Finishes __: **GS** (BLE, 304S and 316S available upon request)

Part Number	For Tray Depth Of in. (mm)	Qty./Box	Wt./Box lbs. (kg)
2 IN DIVIDER __	2" (50)	1	3.5 (1.59)
4 IN DIVIDER __	4" (100)	1	9.6 (4.35)
6 IN DIVIDER __	6" (150)	1	14.5 (6.58)

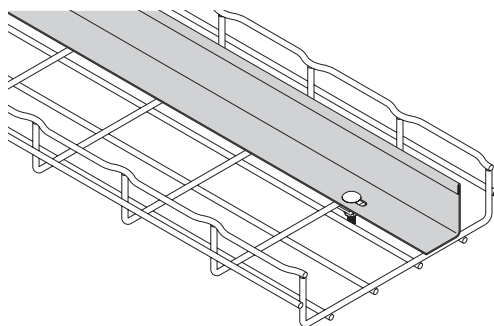

Dividers include hardware shown below

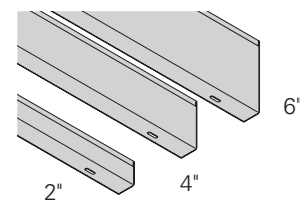
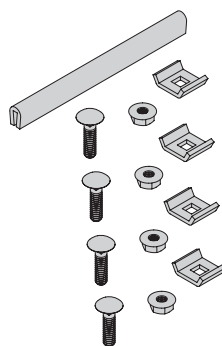

See page D-3 for finish information

Solid bottom inserts

Part Number	For Tray Width Of		Qty./Box	Wt./Box	
	in.	mm		lbs.	kg
INSERT 4X118__	4"	(100)	1	6.8	(3.08)
INSERT 6X118__	6"	(150)	1	9.8	(4.44)
INSERT 8X118__	8"	(200)	1	13.3	(6.03)
INSERT 12X118__	12"	(300)	1	21.6	(9.80)
INSERT 16X118__	16"	(400)	1	26.4	(11.97)
INSERT 18X118__	18"	(450)	1	32.4	(14.69)
INSERT 20X118__	20"	(500)	1	32.9	(14.92)
INSERT 24X118__	24"	(600)	1	39.3	(17.82)



Attach with
FTHDWE 1/4
& Top Washer

- Continuous support for sensitive cables
- Security of cable in high-traffic areas
- Hardware included
- Available for 4" (100mm) to 24" (600mm) wide trays
- Comes in 118" (2997mm) length
- Finishes __: **GS** (BLE, 304S and 316S also available upon request)

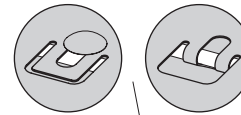

Attachment
methods

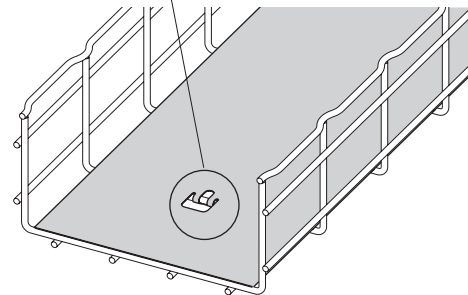

Blind ends

Part Number	'A' in. (mm)	Height in. (mm)	Box Quantity
FT BE 2X2	2" (50)	2" (50)	1
FT BE (*)X4	4" (100)	(*) (*)	1
FT BE (*)X6	6" (150)	(*) (*)	1
FT BE (**)X8	8" (200)	(*) (*)	1
FT BE (**)X12	12" (300)	(**) (**)	1
FT BE (**)X16	16" (400)	(**) (**)	1
FT BE (**)X18	18" (450)	(**) (**)	1
FT BE (**)X20	20" (500)	(**) (**)	1
FT BE (**)X24	24" (600)	(**) (**)	1

- Tab features eliminate need for hardware
- Forms a closure for a dead-end Flextray
- Hardware included
- Finish: **GLV** (SS6 also available upon request)

(*) Insert: 2 = 2" (50 mm), 4 = 4" (100 mm) for height

(**) Insert: 2 = 2" (50mm), 4 = 4" (100mm),
6 = 6" (150mm) for height

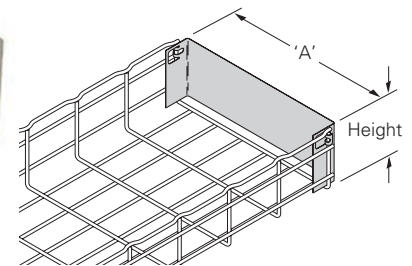

Strut mounting clip

Part Number	Description	Qty./Box	Wt./Box lbs. (kg)
BW4	Strut Mounting Clip	100	0.9 (0.41)



- Use to secure FLEXTRAY to horizontal strut support
- Designed for use as shown in drawing (no load rating)
- Finish: Black Zinc Phosphate

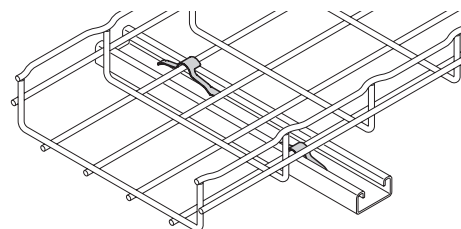

See page D-3 for finish information

Cable roller

- Protects and maintains recommended cable radii for Cat 5, Cat 5E, Cat 6, Cat 6A, Fiber, etc.
- Height of roller can be adjusted to tray depth
- Installs in seconds with no tools
- Reduces cable installation time
- Prevents migration of cables
- For use with 4" (100mm) to 32" (800mm) tray widths
- Finish: Cast Aluminum

Part Number	Description	Qty./Box	Wt./Box lbs. (kg)
CABLE ROLLER	Cable Roller	1	1.0 (0.45)

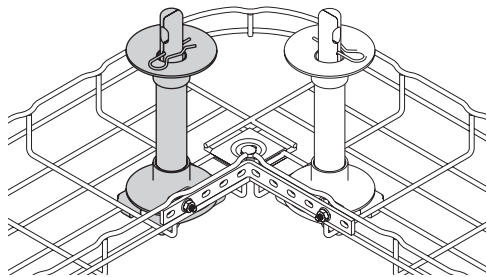

Quick, snap-together design

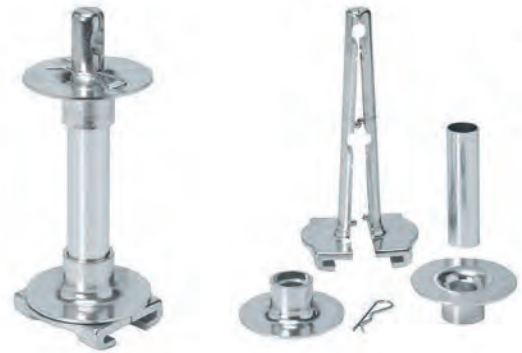

Toolless clip

- Securely holds tray to support
- Snap-in locking pin
- No tools or fastening required
- Fast hold-down method
- For use with the following:
 - FTB_CS (see pg. D-26)
 - L BRKT (see pg. D-26)
 - C BRKT (see pg. D-30)
- Finish: Plenum rated resin (black)

Part Number	Description	Qty./Box	Wt./Box lbs. (kg)
TOOLESS CLIP	Toolless Hold-Down Clip	50	1.0 (0.45)



Conduit connector

- Conduit connector is designed to connect conduit to the side or bottom of Flextray
- Conduit bushing will remain outside of tray to keep cable pathway clear
- Bend tabs to secure connector to tray
- No hardware included
- Finishes __: **GLV**

Part Number	Conduit Size in. (mm)	Qty./Box	Wt./Box lbs. (kg)
FTA050CC__	1/2" (15)	10	2.0 (0.91)
FTA075CC__	3/4" (20)	10	2.0 (0.91)
FTA100CC__	1" (25)	10	2.0 (0.91)
FTA125CC__	1 1/4" (32)	10	2.0 (0.91)

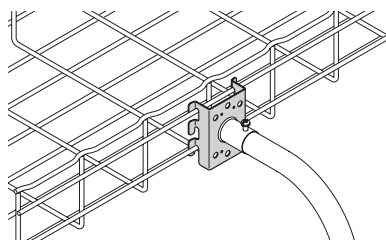

See page D-3 for finish information

Drop out fitting

Part Number	Description	Qty./Box	Wt./Box lbs. (kg)
DROP OUT__	Drop Out Fitting	50	15.0 (6.8)

- Keeps cable radius secure at drop point
- Retention tabs to secure positioning
- For use with 4" (100mm) to 32" (800mm) wide trays
- Attaches to tray without hardware
- Drop outs can be attached at bottom, side or ends of tray
- Retention tabs on bottom of drop out to secure positioning
- Finishes __: **EG** (BLE and SS6 also available upon request)

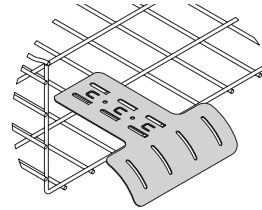
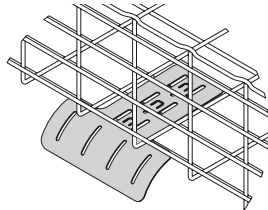

Side drop out fitting

Part Number	Width in. (mm)	Qty./Box	Wt./Box lbs. (kg)
FTA6SDO	6.0 (152.4)	10	7.17 (3.2)
FTA8SDO	8.0 (203.2)	10	9.57 (4.3)
FTA12SDO	12.0 (304.8)	10	14.35 (6.5)

- Keeps cable radius secure at drop point
- For use with 4" (100mm) to 32" (800mm) wide trays (Fig. 1)
- For use with 6" (152mm) to 12" (300mm) wide trays (Fig. 2)
- Drop outs can be attached at side or ends of tray as shown
- Finishes __: **EG** (BLE and SS6 also available upon request)

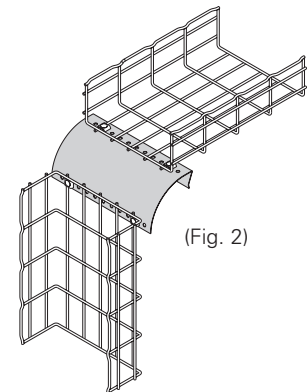
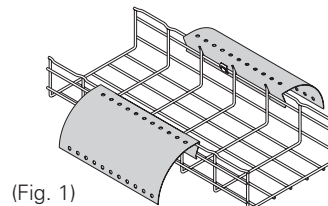

Cable drop out

Part Number	Description	Qty./Box	Wt./Box lbs. (kg)
FTA2DO	Cable Drop Out	10	0.17 (0.08)

- Non-metallic 2" (50mm) radius Cable Drop-Out snap locks into mesh bottom and protects cables from sharp bend
- Material: Black Plenum-rated Plastic

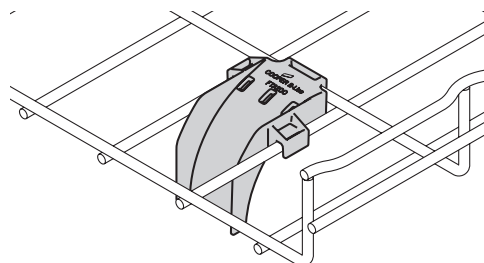

See page D-3 for finish information

Rack clamp

- Securely holds tray down to rack
- Installs without drilling
- Black-painted finish to match rack
- Finish__: **BLE**

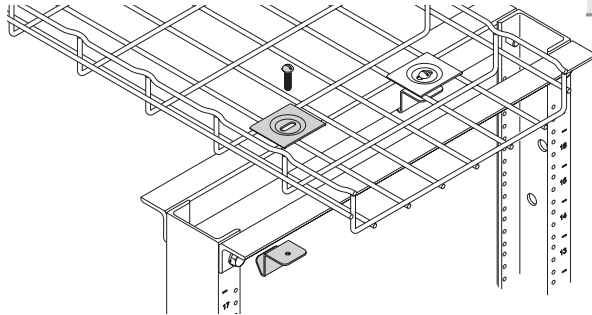

Part Number	Description	Qty./Box	Wt./Box lbs. (kg)
RACK CLAMP__	Rack Clamp	4	4.7 (2.13)



Adaptor kit

- Adaptor kit includes all hardware necessary to connect Flextray system to top of relay rack at right angle or parallel position
- Finish__: **YZN**

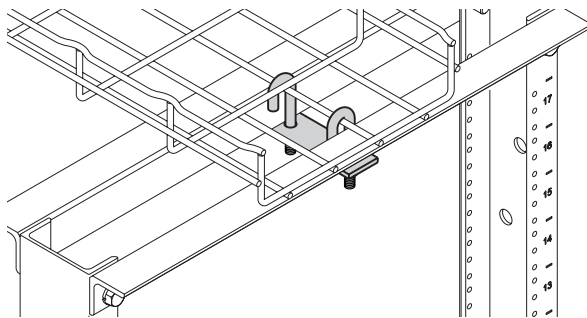

Part Number	Description	Qty./Box	Wt./Box lbs. (kg)
SB2204__	Adaptor Kit	1	0.37 (0.17)

- Adaptor Kit includes:
- (1) - Mounting Plate
 - (2) - $\frac{5}{16}$ "-18 x 2" "J"-Bolts
 - (2) - HN $\frac{5}{16}$ "-18 Hex Nuts
 - (2) - LW $\frac{5}{16}$ " Lock Washers



- Provides a smooth inside radius surface.
- No tools or fasteners needed to install.
- Sizes for 2", 4" & 6" deep Flextray; 90° horizontal bends, tees, and crosses.
- Installs in seconds. Simply hold in place and bend back tabs.
- Slick surface to reduce cable friction.
- Material: Black Polycarbonate

Radius shield

Part Number	Height A in. (mm)	Qty./Box	Wt./Box lbs. (kg)
FTA2RS	2.5 (63)	50	4.0 (1.8)
FTA4RS	4.3 (110)	50	7.0 (3.2)
FTA6RS	5.9 (150)	25	5.0 (2.3)

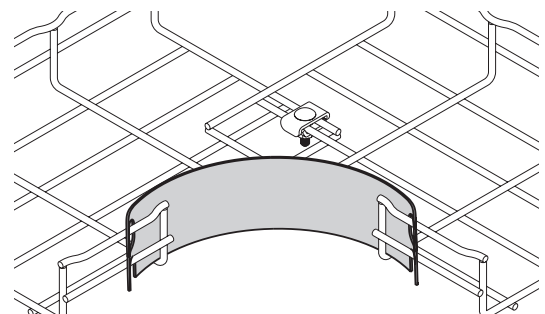
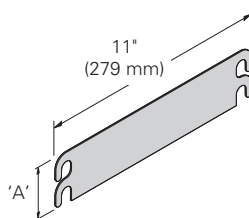

See page D-3 for finish information

Under floor stand

Part Number	Overall Height in. (mm)	Wt. Per Each lbs. (kg)
WBU1203	3" (76)	1.32 (0.60)
WBU1204	4" (101)	1.60 (0.72)
WBU1205	5" (127)	1.88 (0.85)
WBU1206	6" (152)	2.17 (0.98)

- Heights of 3", 4", 5" or 6"
- Leg cutout allows for airflow
- No tools required to mount FLEXTRAY to stand
- Use WBUHD hold down clips to secure basket
- Stand width is 12"
- Fasten to floor for maximum stability
- Floor mounting slot size: .313" (7.9mm) x .813" (20.6mm) for 1/4" hardware



Floor Stand

Part Number	Wt. Per Pc. lbs. (kg)	Box Quantity
FTA2FS	0.44" (0.20)	10

- Non-metallic snap lock floor stand is designed for use under access floors.
- Floor stand elevates Flextray system 1⁵/₈" (41.3mm) above the floor.
- To attach floor stand, use construction adhesive or anchors.
- Elevation increments of 1³/₈" (35mm) can be obtained by stacking floor stands.
- Sized for 1/4" hardware (order separately).
- Material: Black Plenum-rated plastic

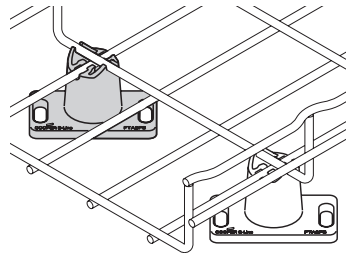

Rubber cap

Part Number	Box Quantity	Wt. Per 100 lbs. (kg)
B719EB	100	0.20 (0.10)

- Install on wire ends if required. Fits all wire diameters
- Sold as each

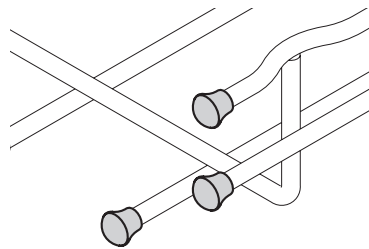

Part Number	Color	Qty./Box	Wt./Box lbs. (kg)
SB420ATG	Gray Lacquer	1	0.9 (0.41)
SB420AFB	Flat Black Lacquer	1	0.9 (0.41)
SB420ACW	Computer White Lacquer	1	0.9 (0.41)
B999	Silver Zinc-Rich Paint	1	0.9 (0.41)

- Size: 12 ounce aerosol can
- Cannot ship air freight

See page D-3 for finish information

Label clip

- Clips easily into trays
- Use for identifying your cable pathways
- Can be used on all tray sizes
- Will not fit on side of 1½" deep Flextray
- Finish: Non-plenum-rated resins

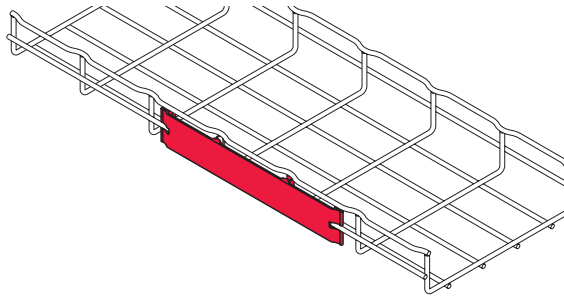

Part Number	Length in. (mm)	Qty./Box	Wt./Box lbs. (kg)
LABEL CLIP	10½" (267)	10	0.6 (0.27)



Ground bolt

- Attaches up to #1 ground wire to each tray section when separate ground wire is required
- Used for UL grounding compliance.
- When using color powder coated finish or paint, coating must be removed at the points of contact.
- Finish: Copper Plated

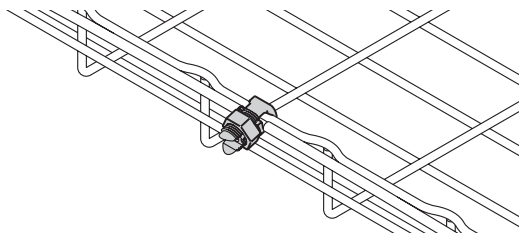

Part Number	Description	Qty./Box	Wt./Box lbs. (kg)
GROUND BOLT	Ground Bolt	100	1.0 (0.45)



Ground wire supports

- Supports ground wire along side of tray
- Can be used on all trays
- Finish __: Zinc plated

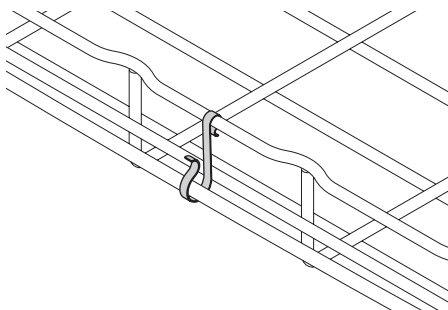

Part Number	Description	Qty./Box	Wt./Box lbs. (kg)
GROUND SUPT GL	Ground Wire Support	100	0.6 (0.27)



See page D-3 for finish information

Flextray - accessories

- Complete source of hardware for ceiling connections
- Available in stock
- Strut can be purchased in pre-cut lengths and various colors
- All hardware is zinc plated

Threaded rod



Part Number	Size	Qty.	Wt./Qty. lbs. (kg)
ATR ^{1/4} x72	1/4" x 72" (1828mm)	1	0.7 (0.31)
ATR ^{1/4} x120	1/4" x 120" (3048mm)	1	1.2 (0.54)
ATR ^{1/4} x144	1/4" x 144" (3657mm)	1	1.4 (0.63)
ATR ^{3/8} x72	3/8" x 72" (1828mm)	1	1.7 (0.77)
ATR ^{3/8} x120	3/8" x 120" (3048mm)	1	2.9 (1.31)
ATR ^{3/8} x144	3/8" x 144" (3657mm)	1	3.5 (1.58)
ATR ^{1/2} x72	1/2" x 72" (1828mm)	1	3.2 (1.45)
ATR ^{1/2} x120	1/2" x 120" (3048mm)	1	5.4 (2.45)
ATR ^{1/2} x144	1/2" x 144" (3657mm)	1	6.5 (2.95)

Rod couplings



Part Number	Size	Qty.	Wt./Qty. lbs. (kg)
B655-1/4	1/4"-20	50	2.0 (0.91)
B655-3/8	3/8"-16	50	5.5 (2.49)
B655-1/2	1/2"-13	50	6.0 (2.72)

Hex Nuts



Part Number	Size	Qty.	Wt./Qty. lbs. (kg)
1/4HN	1/4"-20	100	0.6 (0.27)
3/8HN	3/8"-16	100	1.6 (0.72)
1/2HN	1/2"-13	100	4.3 (1.95)

Lock washers



Part Number	Size	Qty.	Wt./Qty. lbs. (kg)
1/4 LW	1/4"	200	0.6 (0.27)
3/8 LW	3/8"	200	1.6 (0.72)
1/2 LW	1/2"	200	2.0 (0.91)

Flat washers



Part Number	Size	Qty.	Wt./Qty. lbs. (kg)
1/4 FW	1/4"	200	1.2 (0.54)
3/8 FW	3/8"	200	3.0 (1.36)
1/2 FW	1/2"	200	6.6 (2.99)

Square washers



Part Number	Size	Qty.	Wt./Qty. lbs. (kg)
B201	7/16	50	6.0 (2.72)
B202	9/16	50	7.0 (3.17)

Beam Clamps



Part Number	Size	Qty.	Wt./Qty. lbs. (kg)
B3036L-3/8	3/8"-16	100	60.0 (27.2)
B3036L-1/2	1/2"-13	100	140.0 (63.5)

See page D-3 for finish information

Beam clamps



Part Number	Size	Qty.	Wt./Qty. lbs. (kg)
B444-1/4	1/4"-20	100	160 (72.5)
B444-3/8	3/8"-16	100	430 (195.0)
B444-1/2	1/2"-13	100	430 (195.0)

U-Bolt clamps



Part Number	Size	Qty.	Wt./Qty. lbs. (kg)
B441-22	3/8"-16 x 3 3/8" long	100	160 (72.5)

U-Bolts

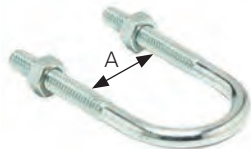

Part Number	'A' in. (mm)	Thread Size	Box Qty	Wt. Per Box lbs. (kg)
B501-1	1 3/8" (30)	5/16"-18	50	7.0 (3.17)
B501-1 1/2	2" (50)	5/16"-18	50	8.0 (3.63)
B501-2	2 7/16" (62)	3/8"-16	20	5.4 (2.45)
B501-2 1/2	2 15/16" (75)	3/8"-16	25	8.0 (3.63)

B22S B22SH B56SH B56S



Strut channels

Part Number	Channel Size	Qty.	Wt./Qty. lbs. (kg)
B22SGALV120	1 5/8" x 120" - 12 ga.	1	6.0 (2.72)
B22SHGALV120	1 5/8" x 120" - 12 ga.	1	6.0 (2.72)
B56SGALV120	1 3/16" x 120" - 15 ga.	1	7.0 (3.17)
B56SHGALV120	1 3/16" x 120" - 15 ga.	1	6.0 (2.72)

Spring nuts



Part Number	Thread Size	Qty.	Wt./Qty. lbs. (kg)
N224	1/4"-20	100	6.5 (2.95)
N228	3/8"-16	100	9.3 (4.22)
N225	1/2"-13	100	11.3 (5.12)

Concrete Rapid Rod™ hanger



Part Number	Rod Size	Shank Size	Qty.	Wt./Qty. lbs. (kg)
ARC-37-150	3/8"	1/4" x 1 1/2"	100	3.4 (1.54)

Wood Rapid Rod™ hanger



Part Number	Rod Size	Shank Size	Qty.	Wt./Qty. lbs. (kg)
ARW-37-200	3/8"	1/4" x 2"	100	3.4 (1.54)
ARW-37-200SW	3/8"	1/4" x 2"	100	3.4 (1.54)

SW = Side Mount

Steel Rapid Rod™ hanger



Part Number	Rod Size	Shank Size	Qty.	Wt./Qty. lbs. (kg)
ARS-37-150	3/8"	1/4" x 1 1/2"	100	3.4 (1.54)
ARS-37-150SW	3/8"	1/4" x 1"	100	3.4 (1.54)

SW = Side Mount

Sockets for Rapid Rod hangers

Part Number	Size	Qty.	Wt./Qty. lbs. (kg)
7187	Universal Steel & Wood Socket	1	4.5 (2.04)
7197	3/8" Concrete Socket	1	4.5 (2.04)

See page D-3 for finish information

Flextray cutters

- Exclusive, patented Cleanshear™ cuts tray fast
- No sharp edges
- Designed specifically for cutting Flextray
- Safely cut and bend Flextray into any configuration

Part Number	Description	Qty./Box	Wt./Box lbs. (kg)
CLEANSHEAR	CLEANSHEAR Cutting Tool	1 per box	4.3 (1.95)



1 Face tray up. Slide cutter next to vertical wire and cut.



2 Turn tray to the side with open side facing you. Repeat step 1 to cut wire.



3 Finish cutting all side wires.



4 Turn tray open-side down and cut wires from bottom of tray.



5 Finish cutting by moving to other side of tray to cut remaining wires.

- Cleanshear bender has our exclusive bending attachment
- Makes bending larger trays easy
- Recommended for bending tray widths of 16" (400mm) or greater

Flextray bender

Part Number	Description	Qty./Box	Wt./Box lbs. (kg)
CLEANSHEAR BEND	CLEANSHEAR Cutting Tool With Bender Attachment	1 per box	5.4 (2.45)

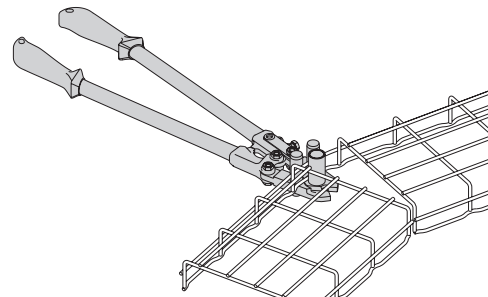

90° Horizontal bends (short radius)

- Make your own field cut horizontal bends using Cleanshear to make safe, smooth cuts
- Can be made from any tray width and depth with any available finish
- SUPT WASHER & FT4DWE 1/4 hardware may be used on bottom of tray instead of WASHER SPL KIT where desired

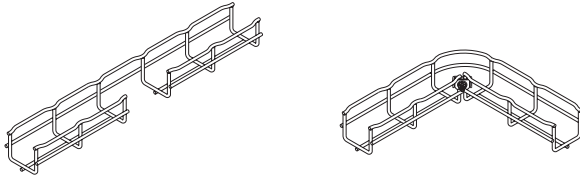

2" (50mm) Tray Width

Flextray Depth in. (mm)	Required Hardware Description	Quantity
2" (50)	WASHER SPL KIT	1

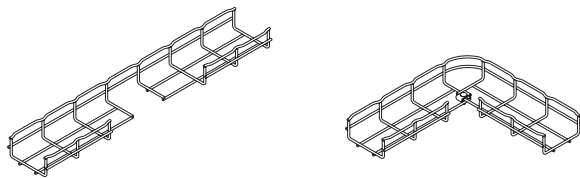

4" (100mm) Tray Width

Flextray Depth in. (mm)	Required Hardware Description	Quantity
2" (50)	WASHER SPL KIT	1
4" (100)	WASHER SPL KIT	1

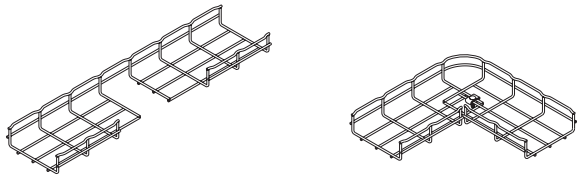

6" (150mm) Tray Width

Flextray Depth in. (mm)	Required Hardware Description	Quantity
2" (50)	WASHER SPL KIT	1
4" (100)	WASHER SPL KIT	1

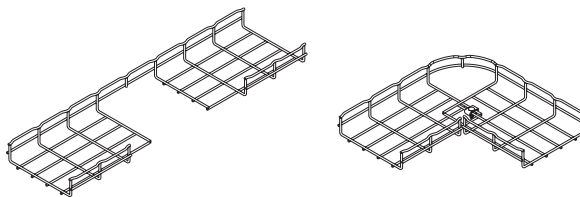

8" (200mm) Tray Width

Flextray Depth in. (mm)	Required Hardware Description	Quantity
2" (50)	WASHER SPL KIT	1
4" (100)	WASHER SPL KIT	1
6" (150)	WASHER SPL KIT	1

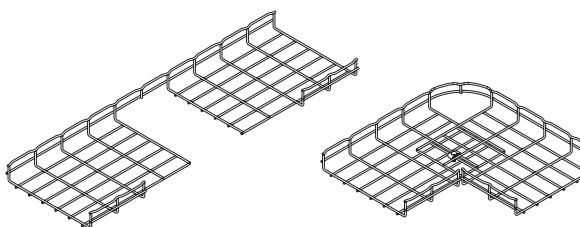

12" (300mm) Tray Width

Flextray Depth in. (mm)	Required Hardware Description	Quantity
2" (50)	WASHER SPL KIT	1
4" (100)	WASHER SPL KIT	1
6" (150)	WASHER SPL KIT	1

90° Horizontal bends (short radius)

- Make your own field cut horizontal bends using Cleanshear to make safe, smooth cuts
- Can be made from any tray width and depth with any available finish
- SUPT WASHER & FTHDWE 1/4 hardware may be used on bottom of tray instead of WASHER SPL KIT where desired

16" (400mm) Tray Width

Flextray Depth in. (mm)	Required Hardware Description	Quantity
2" (50)	WASHER SPL KIT	3
4" (100)	WASHER SPL KIT	3
6" (150)	WASHER SPL KIT	3

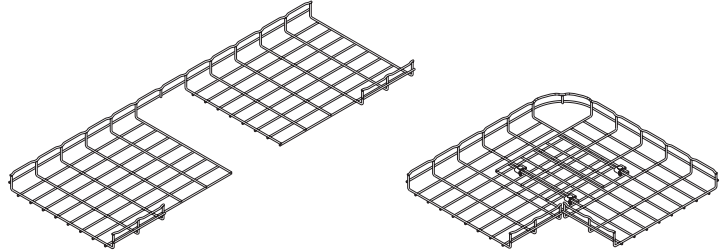

18" (450mm) Tray Width

Flextray Depth in. (mm)	Required Hardware Description	Quantity
2" (50)	WASHER SPL KIT	3
4" (100)	WASHER SPL KIT	3
6" (150)	WASHER SPL KIT	3

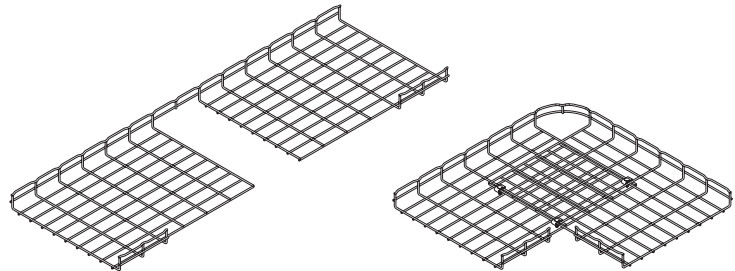

20" (500mm) Tray Width

Flextray Depth in. (mm)	Required Hardware Description	Quantity
2" (50)	WASHER SPL KIT	3
4" (100)	WASHER SPL KIT	3
6" (150)	WASHER SPL KIT	3

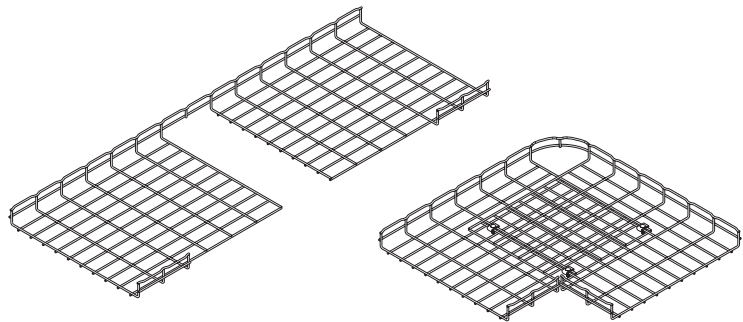

24" (600mm) Tray Width

Flextray Depth in. (mm)	Required Hardware Description	Quantity
2" (50)	WASHER SPL KIT	3
4" (100)	WASHER SPL KIT	3
6" (150)	WASHER SPL KIT	3

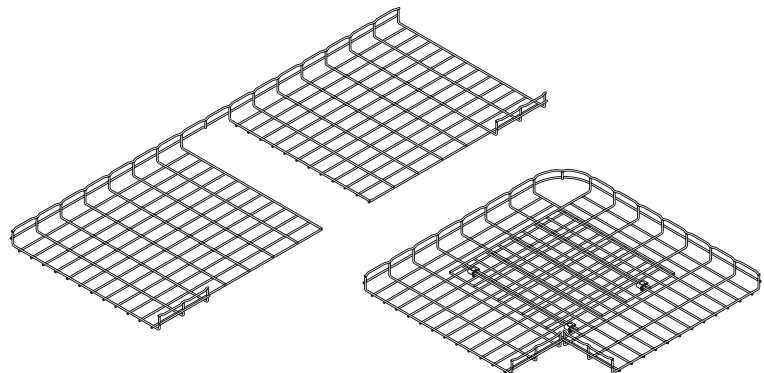

90° Horizontal Bends (Long Radius)

- Make your own field cut horizontal sweeps using Cleanshear to make safe, smooth cuts
 - Can be made from any tray width and depth with any available finish
 - Cut as many segments as required to control sweep radius (use chart for recommendations)
 - One (1) WASHER SPL KIT is required to connect each cut segment minus one, this segment uses one (1) SPLICE BAR, two (2) FTHDWE 1/4 and two (2) BTM WASHER
- Illustration shown below is for a 8" (200mm) width
 - 1.5" deep Flextray has only one (1) side wire
 - 2" deep Flextray has two (2) side wires - shown
 - 4" deep Flextray has three (3) side wires
 - 6" deep Flextray has four (4) side wires

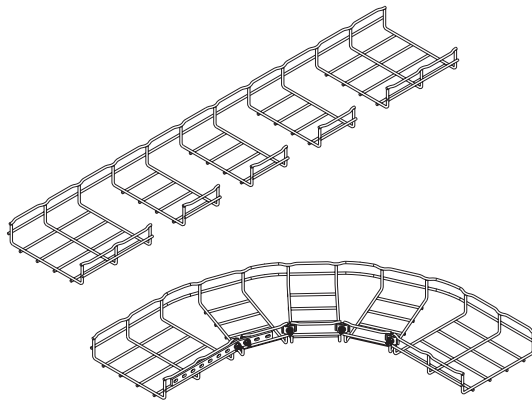

Flextray Width in. (mm)	Segments To Be Removed	Component Qty.		
		WASHER SPL KIT	FTHDWE 1/4 & BTM WASHER	SPLICE BAR
4" (100)	2	1	2	1
6" (150)	3	2	2	1
8" (200)	4	3	2	1
12" (300)	6	5	2	1
16" (400)	7	6	2	1
18" (450)	8	7	2	1
20" (500)	10	9	2	1
24" (600)	11	10	2	1
30" (750)	13	12	2	1
32" (800)	13	12	2	1

90° Horizontal Bend From (2) Straight Sections

- Cut required number of wire side sections listed in chart per the illustration below (Illustration is for a 8" (200mm) width)
- 1.5" deep Flextray has only one (1) side wire
- 2" deep Flextray has two (2) side wires - shown
- 4" deep Flextray has three (3) side wires
- 6" deep Flextray has four (4) side wires

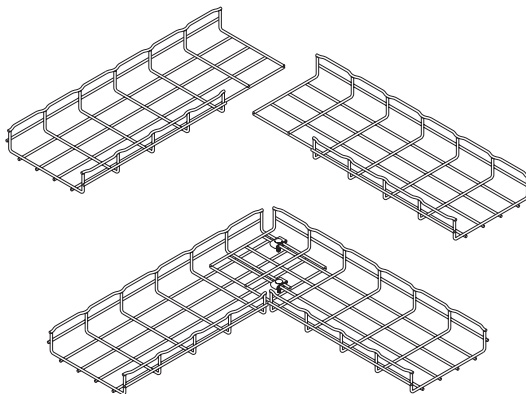

Flextray Width in. (mm)	Side Sections To Be Removed	WASHER SPL KIT Qty.
4" (100)	1	2
6" (150)	2	2
8" (200)	2	2
12" (300)	3	2
16" (400)	4	2
18" (450)	5	2
20" (500)	5	2
24" (600)	6	2
30" (750)	8	2
32" (800)	8	2

Reducers

Large Flextray Width in. (mm)	WASHER SPL KIT		Component Qty. FTHDWE 1/4 & BTM WASHER		SPLICE BAR	
	(SR)	(LRR)	(SR)	(LRR)	(SR)	(LRR)
4" (100)	—	1	—	2	—	1
6" (150)	—	2	—	2	—	1
8" (200)	1	2	4	2	2	1
12" (300)	2	3	4	2	2	1
16" (400)	2	3	4	2	2	1
18" (450)	2	3	4	2	2	1
20" (500)	3	3	4	2	2	1
24" (600)	3	3	4	2	2	1
30" (750)	3	3	4	2	2	1
32" (800)	3	3	4	2	2	1

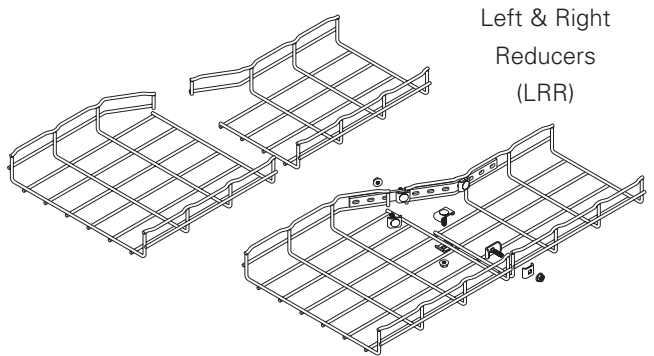
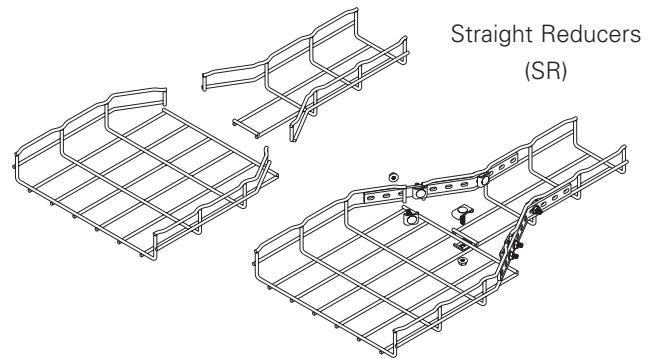

- 1.5" deep Flextray has only one (1) side wire
- 2" deep Flextray has two (2) side wires - shown
- 4" deep Flextray has three (3) side wires
- 6" deep Flextray has four (4) side wires

Vertical inside & outside bends

- Cut wire section as shown and bend to desired angle
- 1.5" deep Flextray has only one (1) side wire
- 2" deep Flextray has two (2) side wires - shown
- 4" deep Flextray has three (3) side wires
- 6" deep Flextray has four (4) side wires

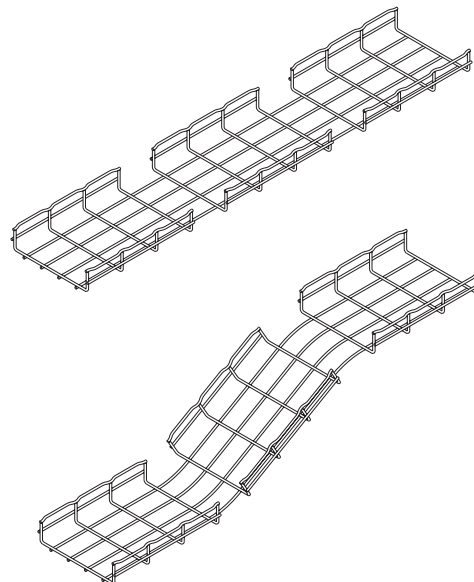

Horizontal tees (and crosses)

- Cut wire side sections as shown in the illustration below (Illustration is for a 8" (200mm) width)
- 2" deep Flextray has two (2) side wires - (shown below)
- 4" deep Flextray has three (3) side wires
- 6" deep Flextray has four (4) side wires
- For crosses, duplicate process on opposite side

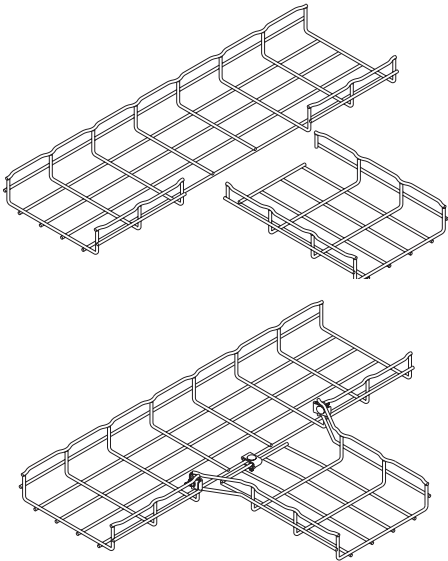

Tray Width in. (mm)	WASHER SPL KIT Qty.
2" (50)	2
4" (100)	2
6" (150)	3
8" (200)	3
12" (300)	4
16" (400)	4
18" (450)	4
20" (500)	4
24" (600)	4
30" (750)	5
32" (800)	5



KSCC Splice Plate
Patent pending

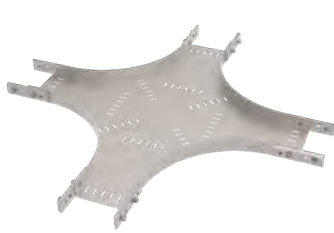

KSCC Horizontal Cross
Patent pending

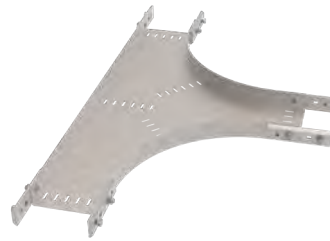

KSCC Horizontal Tee
Patent pending



KSCC Drop Out
Patent pending



KSCC Reducer Splice Plate



KSCC Horizontal Adjustable Splice Plate
Patent pending



KSCC Vertical Adjustable Splice Plate
Patent pending



KSCC Heavy Duty Expansion Splice Plate



KSCC Blind End



KSCC Expansion Splice Plate

How The Service Advisor Works

We know that your time is important! That's why the color-coding system in this catalog is designed to help you select products that fit your service needs. Products are marked to indicate the typical lead time for orders of 50 pieces or less.

Customer: How do I select my cable channel product so that I get the quickest turnaround?

Service Advisor: Each part of our selection chart is shown in colors. If any section of a part number is a different color, the part will typically ship with the longer lead time represented by the colors.

- Green = Fastest shipped items
- Black = Normal lead-time items

Example: **KSCC A 06 - 120**

● ● ● ●

Channel with pass through available to ship in Q3 of 2022.

Straight Section Part Numbering

Example: **KSCC A - 04 - 240**

Prefix

Type	Material	Width	Length
KSCC = Ventilated Cable Channel with Pass Through	<i>Only available in Aluminum</i> A = Aluminum 6063-T6	● 02 = 2"*** ● 04 = 4" ● 06 = 6"	① ● 120 = 10 ft. ② ● 144 = 12 ft. ③ ● 240 = 20 ft.
KSCCS = Ventilated Cable Channel			
KSCCN = Non-Ventilated Cable Channel Solid Bottom			

*** 2" width not offered with KSCC Ventilated Cable Channel with Pass Through



KSCCNA-06-240
Non-Ventilated Cable Channel
Patent pending

**KSCCNA-06,
KSCCA-06 & KSCCSA-06**
6" (150mm) wide
2" (51mm) deep

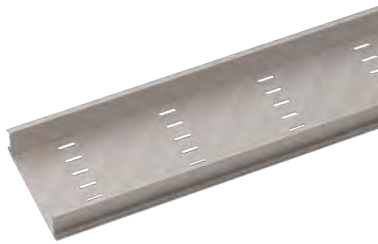
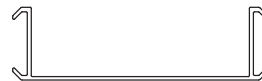

KSCCSA-06-240
Ventilated Cable Channel
Patent pending

**KSCCNA-04,
KSCCA-04 & KSCCSA-04**
4" (100mm) wide
2" (51mm) deep



**KSCCNA-02 &
KSCCSA-02**
2" (51mm) wide
2" (51mm) deep

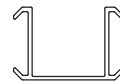

***2x2 not available in KSCCA perforation pattern

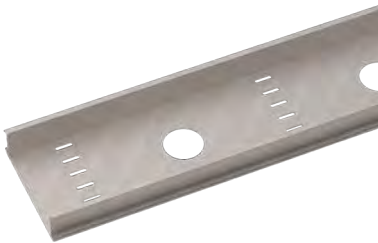

KSCCA-06-240
Ventilated Cable Channel with Pass Through*
Patent pending

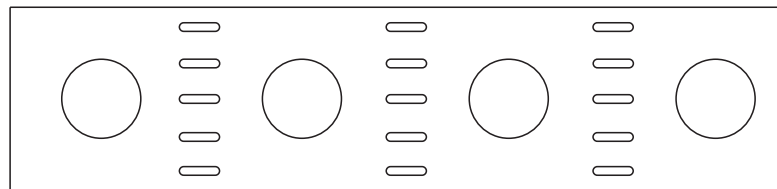

4" wide pattern shown

Ventilated straight sections contain 2 1/4" (57.1mm) pass through and 1/4" (6.4mm) x 1" (25.4mm) slots for cable attachment.

*Pass through hole offering available in Q3 2022.

● Green = Fastest shipped items ● Black = Normal lead-time items

KwikSplice cable channel tray - straight sections

Tray data & loading

Material Type	Tray Series	Width in. (mm)	Depth in. (mm)	UL Cross-Sectional Area	Span		Loading	
					ft.	(m)	lbs/ft	(kg/m)
Aluminum Non-Ventilated solid bottom	KSCCN*A-02	2 (51)	2 (51)	0.40 in ²	10	(3.0)	13	(20)
					12	(3.6)	6	(9)
					20	(6.1)	3	(5)
	KSCCN*A-04	4 (101)	2 (51)	0.60 in ²	10	(3.0)	27	(40)
					12	(3.6)	12	(18)
					20	(6.1)	7	(10)
	KSCCN*A-06	6 (152)	2 (51)	0.60 in ²	10	(3.0)	40	(60)
					12	(3.6)	18	(26)
					20	(6.1)	10	(15)
Aluminum Ventilated slotted	KSCCS*A-02	2 (51)	2 (51)	0.40 in ²	10	(3.0)	13	(20)
					12	(3.6)	6	(9)
					20	(6.1)	3	(5)
	KSCCS*A-04	4 (101)	2 (51)	0.60 in ²	10	(3.0)	27	(40)
					12	(3.6)	12	(18)
					20	(6.1)	7	(10)
	KSCCS*A-06	6 (152)	2 (51)	0.60 in ²	10	(3.0)	40	(60)
					12	(3.6)	18	(26)
					20	(6.1)	10	(15)
Aluminum Ventilated with Pass Through	KSCC*A-04	4 (101)	2 (51)	0.40 in ²	10	(3.0)	27	(40)
					12	(3.6)	12	(18)
					20	(6.1)	7	(10)
	KSCC*A-06	6 (152)	2 (51)	0.60 in ²	10	(3.0)	40	(60)
					12	(3.6)	18	(26)
					20	(6.1)	10	(15)



Pass through hole offering available in Q3 2022.

Splice Plate

Features dove tail locking design which allows for quick installation.

- Furnished in pairs with pre-installed hardware
- 1 size fits all channel widths
Patent pending



Catalog No.	Channel Width	
	in.	(mm)
KSCCA-SSP	2 to 6	(51 to 152)

Horizontal Adjustable Splice Plate

Adapts to changes in direction on a horizontal plane beyond the capability of the standard horizontal fittings.

- Allows 0 to 90° of adjustment
- Furnished as one assembly with hardware
Patent pending



Catalog No.	Channel Width	
	in.	(mm)
KSCCA-02-HSP	2	(51)
KSCCA-04-HSP	4	(101)
KSCCA-06-HSP	6	(152)

Vertical Adjustable Splice Plate

Adapts to changes in direction on a vertical plane beyond the capability of the standard vertical fittings.

- Allows 0 to 90° of adjustment
- Furnished as one assembly with hardware
Patent pending



Catalog No.	Channel Width	
	in.	(mm)
KSCCA-02-VSP	2	(51)
KSCCA-04-VSP	4	(101)
KSCCA-06-VSP	6	(152)

Expansion Splice Plate

Allow for one inch expansion or contraction of the cable channel run. See page C-8 for use instructions.

- 1 size fits all channel widths
Patent pending



Catalog No.	Channel Width	
	in.	(mm)
KSCCA-ESP	2 to 6	(51 to 152)

Requires supports within 24" on both sides, per NEMA VE 2.

Heavy Duty Expansion Splice Plate

Engineered to eliminate the additional supports recommended by NEMA at an expansion joint location.

- Can be placed out to 1/4 support span without requiring any additional supports at junction.
- Can be used on all widths 2", 4" and 6"
- Installation will require field drilling on straight sections



Catalog No.	Channel Width	
	in.	(mm)
KSCCA-HDESP	2 to 6	(51 to 152)

Channel Reducer Plate

Used to join cable channel sections with different widths.

- Product will be boxed with one standard splice plate (included with the kit)
- Requires supports within 24" on both sides per NEMA VE 2



Catalog No.	Channel Width in. (mm)
KSCCA-20FSP	4 to 2 (101-51) 6 to 4 (152-101)
KSCCA-40FSP	6 to 2 (152-51)

Wrap Around Cover Clamp/Bolted Cover Clamp

- Secures the cover to the cable channel
- Furnished as one clamp with hardware



Catalog No.	Channel Width in. (mm)
KSCCA-02-HDCC	2 (51)
KSCCA-04-HDCC	4 (101)
KSCCA-06-HDCC	6 (152)

Hold Down/Guide/Trapeze Support Bracket

- Locks into side rail with channel nut attachment
- No drilling of channel is required
- Furnished as pair of brackets with channel mounting hardware.
- Order $\frac{3}{8}$ " support attachment hardware separately
- Can be used on all widths 2", 4" and 6" widths
- To use part as a guide, torque down the nut before inserting into the channel



Bracket includes dove tail nut

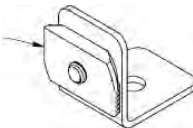

Catalog No.	Channel Width in. (mm)
KSCCA-HLD	2 to 6 (51-152)

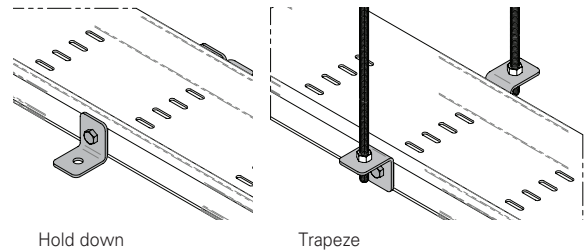

Parallel Tray Mounting Bracket

Allows a parallel run of cable channel to be attached to the side of a cable tray / channel.

- Furnished as one support with channel mounting hardware
- Will support all widths 2", 4" and 6" widths



Catalog No.	Channel Width in. (mm)
KSCCA-UMB	2 to 6 (51-152)

Tray Mounting Bracket

Allows a perpendicular run of cable channel to be attached to the side of a cable tray / channel.

- Furnished as one support with channel mounting hardware
- Will support all widths 2", 4" and 6" widths



Catalog No.	Channel Width in. (mm)
KSCCA-06-TMB	2 to 6 (51-152)

End Drop Out

- Provides 4" (101mm) radius
- Holes provided to help secure cables

Patent pending



Catalog No.	Channel Width in. (mm)
KSCCA-02-OUT	2 (51)
KSCCA-04-OUT	4 (101)
KSCCA-06-OUT	6 (152)

Cable Channel Bushing

Used to help protect cable from mechanical wear.

- Snap in place plastic bushing

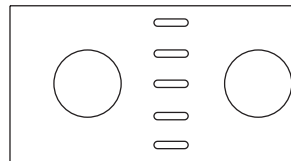

Catalog No.

99-1125

Cable Channel Bracket

- Safety factor of 2.5
- Finishes available: ZN, GRN, HDG

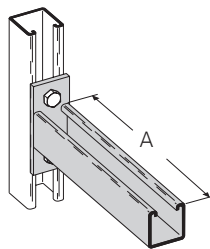

Catalog No.	Channel Width in. (mm)	Uniform Load lbs (kN)	A in. (mm)
B409-6	3 (76)	1920 (8.54)	6 (152)
B409-9	4, 6 (101, 152)	1280 (5.69)	9 (228)

Blind End

Designed to terminate channel run.

- Furnished as one plate with hardware
- Comes pre-assembled as pictured



Catalog No.	Channel Width in. (mm)
KSCCA-02-END	2 (51)
KSCCA-04-END	4 (101)
KSCCA-06-END	6 (152)

Frame Type Connector

Designed to attach the end of a cable channel run to a distribution cabinet or control center.

- Helps reinforce the box at the point of entry
- Furnished with channel connection hardware
- Comes pre-assembled as pictured



Catalog No.	Channel Width in. (mm)
KSCCA-02-FTB	2 (51)
KSCCA-04-FTB	4 (101)
KSCCA-06-FTB	6 (152)

Dove Tail Nut

Used to mount onto dove tail channel.

- The slip load is 300 lbs with a safety factor of 3
- The pull out is 330 lbs with a safety factor of 3



Catalog No.	Channel Width	
	in.	(mm)
KSCC-DTN-SS6	2 to 6	(51-152)

Side Rail Drop Out

Used to drop cable out of the side of the channel.

- Furnished with $\frac{3}{8}$ " bolt and dove tail nut hardware for connection
- Works on all channel widths
- Comes pre-assembled as pictured



Catalog No.	Channel Width	
	in.	(mm)
KSCC-SDO	2 to 6	(51-152)

Cable Drop Opening

Fitting design to provide pass through hole on solid bottom and slotted channel.

- Furnished as one assembly with hardware
- 6" and 4" width have 2 $\frac{1}{4}$ " pass through opening.
- 2" width has 1 $\frac{1}{2}$ " pass through opening
- Comes pre-assembled as pictured

Patent pending



Catalog No.	Channel Width	
	in.	(mm)
KSCCA-02-CDO	2	(51)
KSCCA-04-CDO	4	(101)
KSCCA-06-CDO	6	(152)

Bolted Cover Clamp

- Secures the cover to the cable channel
- Furnished as one clamp with hardware



Catalog No.	Channel Width	
	in.	(mm)
KSCCA-HDCC-02	2	(51)
KSCCA-HDCC-04	4	(101)
KSCCA-HDCC-06	6	(152)

Conduit to Channel Adaptor

- Material: 7 gauge (4.5)
- Standard finishes: ZN, SS4

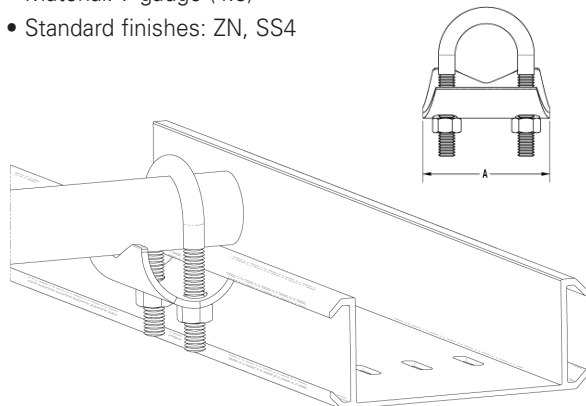

Catalog No.	Conduit size	A	Wt./C
	In. mm	In. mm	Lbs. kg
B422-1/2	1/2" (15)	2 $\frac{3}{8}$ " (60.3)	38 (17.2)
B422-3/4	3/4" (20)	2 $\frac{3}{8}$ " (60.3)	39 (17.7)
B422-1	1" (25)	2 $\frac{7}{8}$ " (73.0)	48 (21.8)
B422-1$\frac{1}{4}$	1 $\frac{1}{4}$ " (32)	2 $\frac{7}{8}$ " (73.0)	50 (22.7)
B422-1$\frac{1}{2}$	1 $\frac{1}{2}$ " (40)	3 $\frac{1}{4}$ " (82.5)	59 (26.7)
B422-2	2 (50)	3 $\frac{11}{16}$ " (93.7)	75 (34.0)
B422-2$\frac{1}{2}$	2 $\frac{1}{2}$ " (65)	4 $\frac{1}{4}$ " (107.9)	98 (44.4)
B422-3	3" (80)	4 $\frac{7}{8}$ " (123.8)	111 (50.3)
B422-3$\frac{1}{2}$	3 $\frac{1}{2}$ " (90)	5 $\frac{7}{16}$ " (138.1)	123 (55.8)
B422-4	4" (100)	6" (152.4)	135 (61.2)

Note: Recommended torque would be 11 ft-lbs.
Max torque would be 15 ft-lbs.

Cable Channel Covers



Aluminum

Standard Straight Section

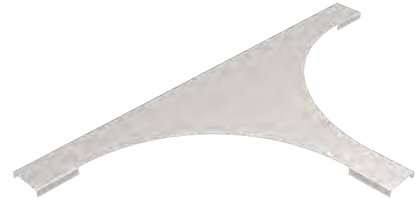

Fitting Covers
Horizontal Tee (HT) shown above

Straight Section Covers Part Numbering

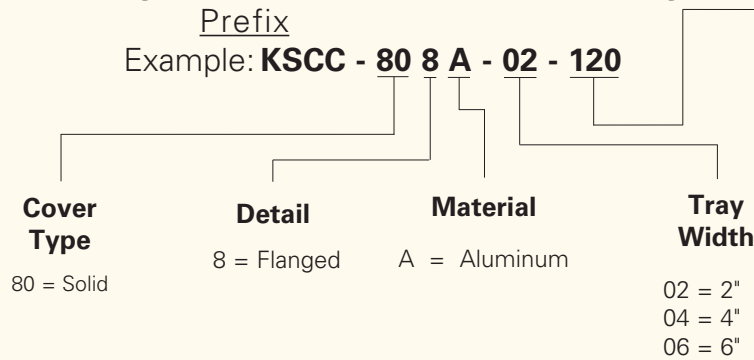

Item Description

Straight sections covers are only available in aluminum.

- 144 = 12 ft.
- 120 = 10 ft.
- 72 = 6 ft.
- 60 = 5 ft.

See below for fitting catalog number examples.

Fittings Part Numbering

To order covers for fittings, reference examples below.

Horizontal Bend Cover Example

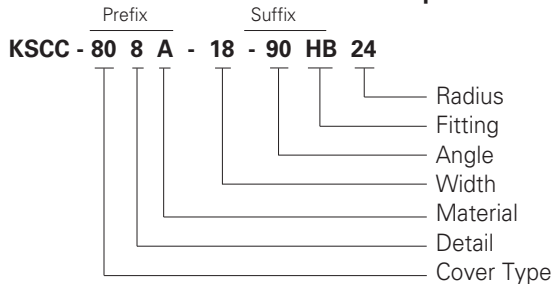

Vertical Bend Cover Example

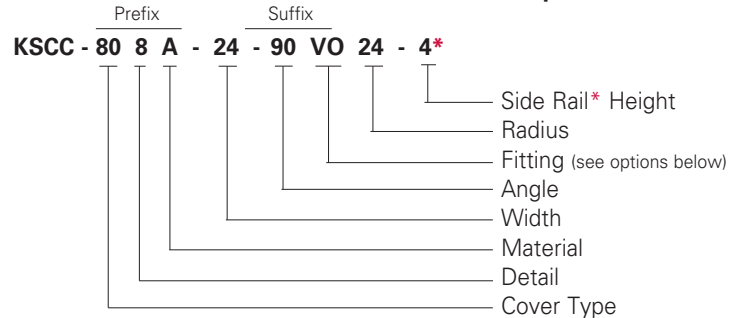

Fitting Options

- HB_ = Horizontal Bend
- HT_ = Horizontal Tee
- HX_ = Horizontal Cross
- VI_ = Vertical Inside Bend
- VO_ = Vertical Outside Bend

* Required for vertical outside (VO) fittings only

Fittings engineered with 3" tangents for splicing integrity.



90° Horizontal bend fitting
Patent pending

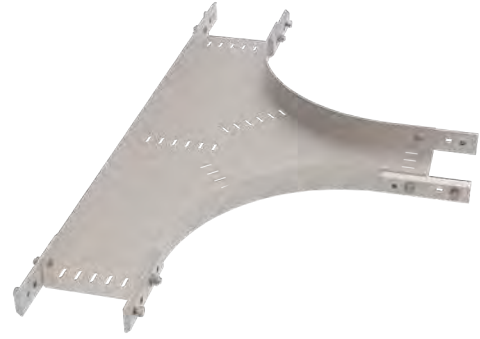

Horizontal tee
Patent pending



45° Horizontal bend fitting
Patent pending



Horizontal cross
Patent pending

Fittings Part Numbering

Example: **KSCC A- 06 - 90 HB 12**

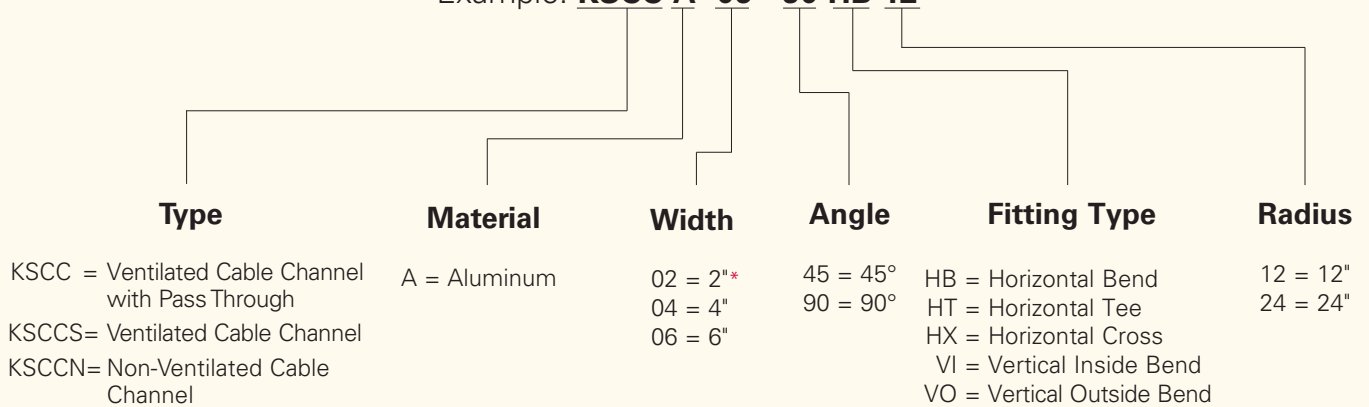

* 2" width not offered with KSCC Ventilated Cable Channel with Pass Through

90° Horizontal Bend (HB)

- Factory mounted splice plate and hardware included



90° Horizontal Bend
Ventilated perforation style shown

Catalog No.	Bend Radius		Tray Width		90° Horizontal Bend					
	R				A		B		C	
	in.	(mm)	in.	(mm)	in.	(mm)	in.	(mm)	in.	(mm)
(Pre)-02-90HB12	12	(305)	2	(25)	17.0	(432)	17	(432)	17	(432)
(Pre)-04-90HB12			4	(101)	17.0	(432)	17	(432)	17	(432)
(Pre)-06-90HB12			6	(152)	17.0	(432)	17	(432)	17	(432)
(Pre)-02-90HB24	24	(610)	2	(25)	29.0	(737)	29	(737)	29	(737)
(Pre)-04-90HB24			4	(101)	29.0	(737)	29	(737)	29	(737)
(Pre)-06-90HB24			6	(152)	29.0	(737)	29	(737)	29	(737)

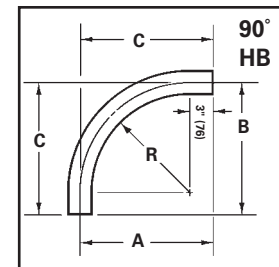

45° Horizontal Bend (HB)

- Factory mounted splice plate and hardware included



45° Horizontal Bend
Ventilated perforation style shown

Catalog No.	Bend Radius		Tray Width		45° Horizontal Bend					
	R				A		B		C	
	in.	(mm)	in.	(mm)	in.	(mm)	in.	(mm)	in.	(mm)
(Pre)-02-45HB12	12	(305)	2	(25)	15.0	(382)	6.222	(158)	8.799	(223)
(Pre)-04-45HB12			4	(101)	15.0	(382)	6.222	(158)	8.799	(223)
(Pre)-06-45HB12			6	(152)	15.0	(382)	6.222	(158)	8.799	(223)
(Pre)-02-45HB24	24	(610)	2	(25)	23.5	(597)	9.737	(247)	13.77	(350)
(Pre)-04-45HB24			4	(101)	23.5	(597)	9.737	(247)	13.77	(350)
(Pre)-06-45HB24			6	(152)	23.5	(597)	9.737	(247)	13.77	(350)

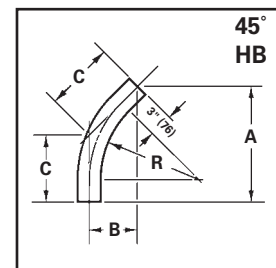

(Pre) = prefix. See page E-10 for catalog number prefix.

Horizontal Tee (HT)

- Factory mounted splice plate and hardware included

Catalog No.	Bend Radius		Tray Width		Horizontal Tee			
	in.	(mm)	in.	(mm)	A		B	
(Pre)-02-HT12			2	(25)	16	(406)	32	(813)
(Pre)-04-HT12	12	(305)	4	(101)	17	(432)	34	(864)
(Pre)-06-HT12			6	(152)	18	(457)	36	(914)
(Pre)-02-HT24			2	(25)	28	(711)	56	(1422)
(Pre)-04-HT24	24	(610)	4	(101)	29	(737)	58	(1473)
(Pre)-06-HT24			6	(152)	30	(762)	60	(1524)



Horizontal Tee
Ventilated perforation style shown

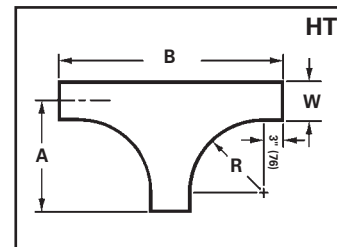

Horizontal Cross (HX)

- Factory mounted splice plate and hardware included

Catalog No.	Bend Radius		Tray Width		Horizontal Cross			
	in.	(mm)	in.	(mm)	A		B	
(Pre)-02-HX12			2	(25)	16	(406)	32	(813)
(Pre)-04-HX12	12	(305)	4	(101)	17	(432)	34	(864)
(Pre)-06-HX12			6	(152)	18	(457)	36	(914)
(Pre)-02-HX24			2	(25)	28	(711)	56	(1422)
(Pre)-04-HX24	24	(610)	4	(101)	29	(737)	58	(1473)
(Pre)-06-HX24			6	(152)	30	(762)	60	(1524)



Horizontal Cross
Ventilated perforation style shown

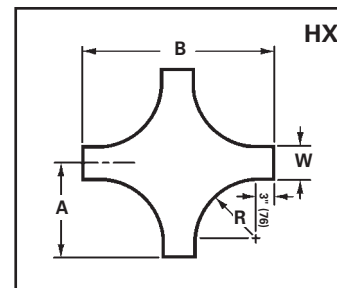

(Pre) = prefix. See page E-10 for catalog number prefix.

90° Vertical Outside Bends (VO)

- Factory mounted splice plate and hardware included



90° Vertical Outside Bend
Ventilated perforation style shown

Catalog No.	Bend Radius		Tray Width		90° Vertical Outside Bend					
	in.	(mm)	in.	(mm)	A		B		C	
					in.	(mm)	in.	(mm)	in.	(mm)
(Pre)-02-90VO12	12	(305)	2	(25)	15	(381)	15	(381)	15	(381)
(Pre)-04-90VO12			4	(101)	15	(381)	15	(381)	15	(381)
(Pre)-06-90VO12			6	(152)	15	(381)	15	(381)	15	(381)
(Pre)-02-90VO24	24	(610)	2	(25)	27	(686)	27	(686)	27	(686)
(Pre)-04-90VO24			4	(101)	27	(686)	27	(686)	27	(686)
(Pre)-06-90VO24			6	(152)	27	(686)	27	(686)	27	(686)

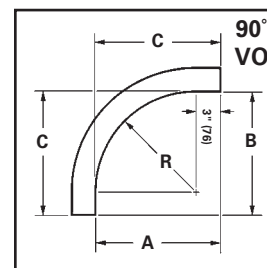

45° Vertical Outside Bends (VO)

- Factory mounted splice plate and hardware included



45° Vertical Outside Bend
Ventilated perforation style shown

Catalog No.	Bend Radius		Tray Width		45° Vertical Outside Bend					
	in.	(mm)	in.	(mm)	A		B		C	
					in.	(mm)	in.	(mm)	in.	(mm)
(Pre)-02-45VO12	12	(305)	2	(25)	13.607	(346)	5.6	(143)	7.971	(202)
(Pre)-04-45VO12			4	(101)	13.607	(346)	5.6	(143)	7.971	(202)
(Pre)-06-45VO12			6	(152)	13.607	(346)	5.6	(143)	7.971	(202)
(Pre)-02-45VO24	24	(610)	2	(25)	22.092	(561)	9.2	(232)	12.941	(329)
(Pre)-04-45VO24			4	(101)	22.092	(561)	9.2	(232)	12.941	(329)
(Pre)-06-45VO24			6	(152)	22.092	(561)	9.2	(232)	12.941	(329)

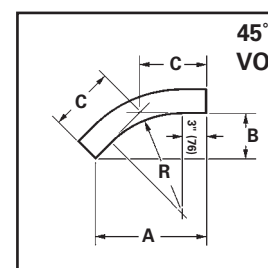

(Pre) = prefix. See page E-10 for catalog number prefix.

90° Vertical Inside Bends (VI)

- Factory mounted splice plate and hardware included

Catalog No.	Bend Radius		Tray Width		90° Vertical Inside Bend					
	in.	(mm)	in.	(mm)	A		B		C	
(Pre)-02-90VI12	12	(305)	2	(25)	17.0	(432)	17	(432)	17	(432)
(Pre)-04-90VI12			4	(101)	17.0	(432)	17	(432)	17	(432)
(Pre)-06-90VI12			6	(152)	17.0	(432)	17	(432)	17	(432)
(Pre)-02-90VI24	24	(305)	2	(25)	29.0	(737)	29	(737)	29	(737)
(Pre)-04-90VI24			4	(101)	29.0	(737)	29	(737)	29	(737)
(Pre)-06-90VI24			6	(152)	29.0	(737)	29	(737)	29	(737)



90° Vertical Inside Bend
Ventilated perforation style shown

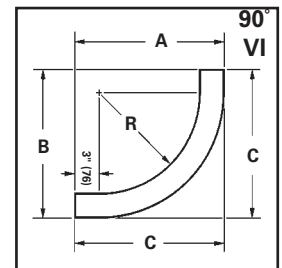

45° Vertical Inside Bends (VI)

- Factory mounted splice plate and hardware included

Catalog No.	Bend Radius		Tray Width		45° Vertical Inside Bend					
	in.	(mm)	in.	(mm)	A		B		C	
(Pre)-02-45VI12	12	(305)	2	(25)	15.0	(382)	6.222	(158)	8.799	(223)
(Pre)-04-45VI12			4	(101)	15.0	(382)	6.222	(158)	8.799	(223)
(Pre)-06-45VI12			6	(152)	15.0	(382)	6.222	(158)	8.799	(223)
(Pre)-02-45VI24	24	(305)	2	(25)	23.5	(597)	9.737	(247)	13.77	(350)
(Pre)-04-45VI24			4	(101)	23.5	(597)	9.737	(247)	13.77	(350)
(Pre)-06-45VI24			6	(152)	23.5	(597)	9.737	(247)	13.77	(350)



45° Vertical Inside Bend
Ventilated perforation style shown

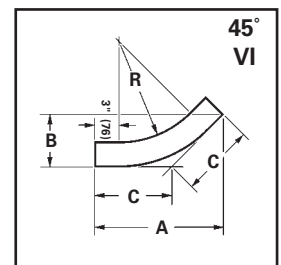

(Pre) = prefix. See page E-10 for catalog number prefix.

Section 1- Acceptable Manufacturers

- 1.1 **Manufacturer:** Subject to compliance with these specifications, B-Line series channel cable tray systems shall be as manufactured by Eaton.

Section 2- Selection and Components

- 2.1 **General:** Except as otherwise indicated, provide ventilated metal channel cable trays, of types, classes and sizes indicated with splice connectors, fittings and all other necessary accessories for a complete system. Provide channel cable tray with rounded edges and smooth surfaces in compliance with applicable standards and with the following additional requirements.
- 2.2 **Materials and finishes:** Material and finishes specifications for each channel cable tray are as follows:
- A. **Aluminum:** Extruded components shall be made from Aluminum Association Alloy 6063. All fabricated parts shall be made from Aluminum Association Alloy 5052.
- 2.3 Cable channel straight sections shall consist of a singularly extruded channel shaped body that includes dove tail openings on each channel upright for the explicit purposes of:
- A. Accommodating field cuts at any point on the section of cable channel without the need for additional modification, splices, hardware and/or labor
 - B. Attachment of splices, fittings and/or accessories in the creation of the desired cable channel system
- 2.4 The cable channel shall have a post-punched pattern on the underside of the profile consistent with one of the following:
- A. Ventilating cable channel with pass through holes: a repeating uniform perforated pattern with 2.25 diameter cable pass through holes every 12 inches.
 - B. Ventilating cable channel: a repeating uniform perforated pattern for ventilation every 6 inches without pass through holes.
 - C. Non-ventilating cable channel (solid bottom).
- 2.5 Straight sections shall be supplied in standard [10 ft (3 m)] [12 ft (4 m)] [20 foot (6 m)] lengths, except where shorter lengths are permitted to facilitate cable channel assembly as shown on drawings.
- 2.6 Channel cable tray width shall be [2] [4] [6] inches with a minimum loading depth of 2 inches.
- 2.7 Fittings shall have a minimum radius of [12] [24] inches.
- 2.8 Each straight section of cable channel:
- A. Shall include pre-assembled splices and hardware.
 - B. Pre-assembled splices and hardware can be pre-installed in straight sections upon request.
- 2.9 Fittings are to be supplied with pre-installed splices.
- 2.10 Loading Capacities
- A. Cable channels shall be capable of carrying a uniformly distributed load of 10 lbs./ft. on a 20-foot support span with a safety factor of 1.5 when supported as a simple span and tested per NEMA VE 1 Section 5.2
- 2.11 Accessories to facilitate cable channel assembly as shown on drawings.
- A. Splices
 - 1. Shall be universally compatible for all cable channel widths.
 - 2. Shall be pre-assembled for immediate field installation.
 - 3. The resistance of fixed splice connections between adjacent sections of cable channel shall not exceed 0.00033 ohms.

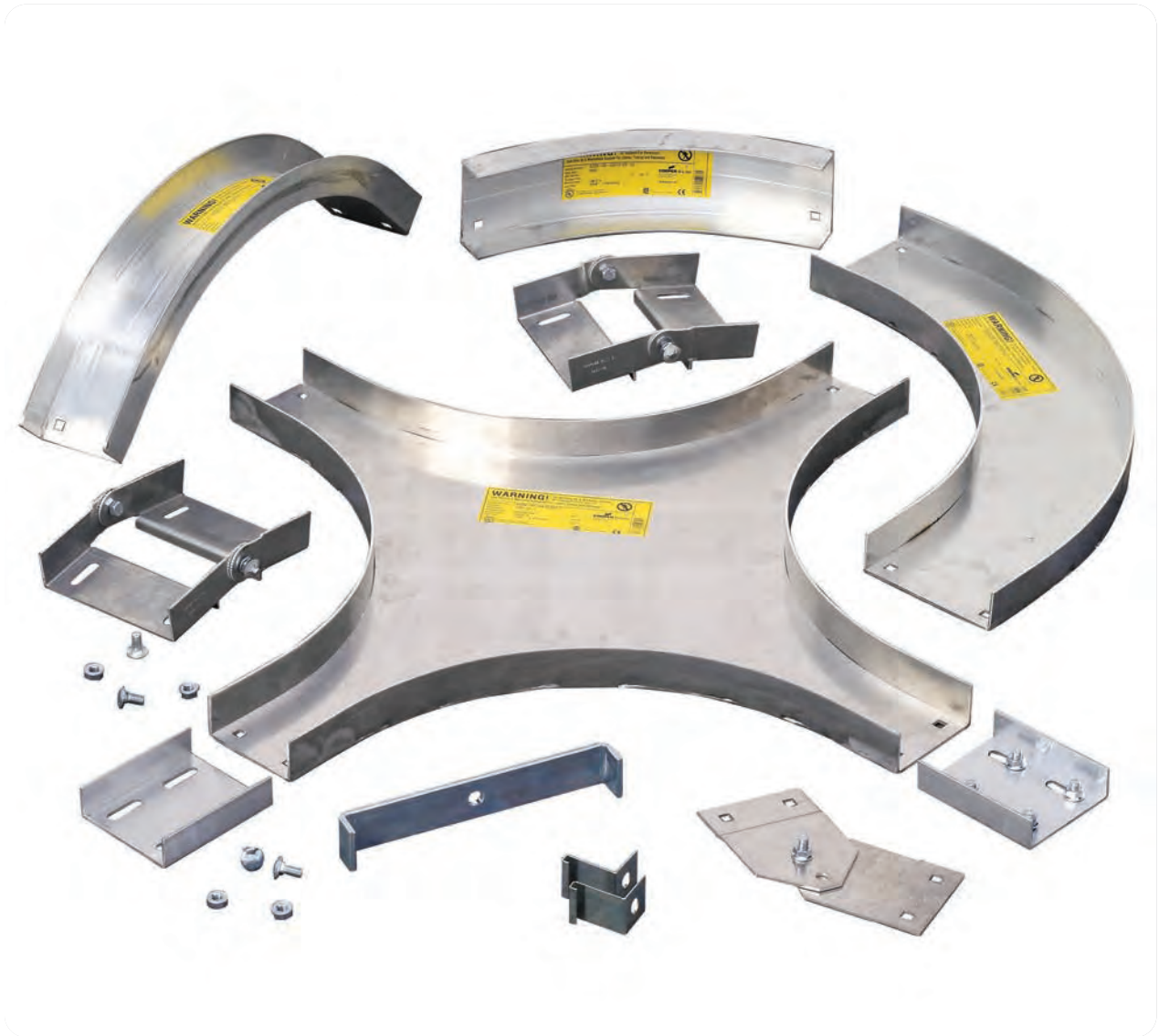

How The Service Advisor Works

We know that your time is important! That’s why the color-coding system in this catalog is designed to help you select products that fit your service needs. Products are marked to indicate the typical lead time for orders of 50 pieces or less.

Customer: How do I select my cable channel product so that I get the quickest turnaround?

Service Advisor: Each part of our selection chart is shown in colors. If any section of a part number is a different color, the part will typically ship with the longer lead time represented by the colors.

- Green = Fastest shipped items
- Black = Normal lead-time items
- Red = Normally long lead-time items

Example: ● A ● CC ● 03 ● 144

Part will have a normal lead time because of the 03 width.

Changing the part number to 04 width instead of 03 will reduce the lead time.

Straight Section Part Numbering

Example: **A CC - 04 - 120**

Material	Type	Width	Length
● A = Aluminum 6063-T4	● CC = Ventilated Cable Channel	● 03 = 3"	● ① 144 = 12 ft.
● G = Type 1 - HDGAF	● CCN = Non-Ventilated Cable Channel	● 04 = 4"	● ② 120 = 10 ft.
● P = Type 2 - Pre-Galvanized		● 06 = 6"	① Primary Length. ② Secondary Length.
● SS4 = 304 Stainless Steel			See page C-23 for explanation of lengths.
● SS6 = 316 Stainless Steel			

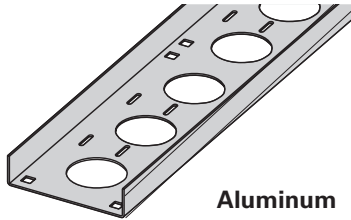

ACC & ACCN03
3" (75mm) wide
1 1/4" (32mm) deep



PCC & PCCN03
SS4CC & SS4CCN03
SS6CC & SS6CCN03
3" (75mm) wide
1 1/4" (32mm) deep

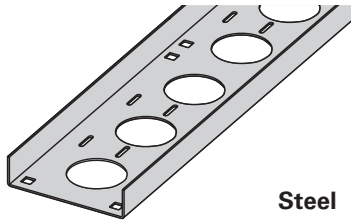

ACC & ACCN04
4" (100mm) wide
1 3/4" (44mm) deep



PCC & PCCN04
SS4CC & SS4CCN04
SS6CC & SS6CCN04
4" (100mm) wide
1 3/4" (44mm) deep



Ventilated

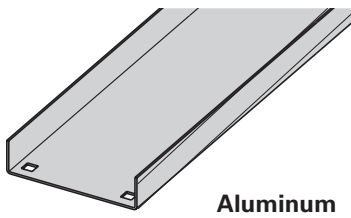

ACC & ACCN06
6" (150mm) wide
1 3/4" (44mm) deep



PCC & PCCN06
SS4CC & SS4CCN06
SS6CC & SS6CCN06
6" (150mm) wide
1 3/4" (44mm) deep

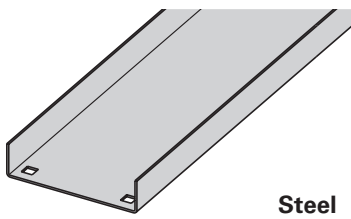

Non-Ventilated

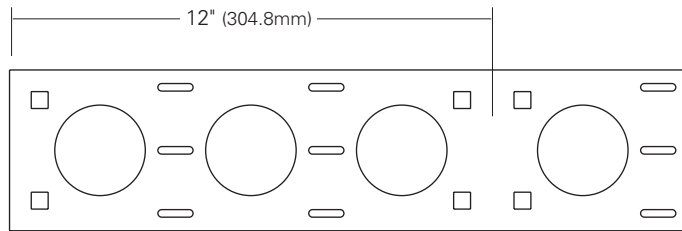

4" wide pattern shown

Ventilated straight sections contain 2 1/4" (57.1mm) diameter holes and 3/16" (4.7mm) x 7/8" (22.2mm) slots for cable attachment. Ventilated straight sections also have splice holes repeating every 12" (304.8mm) to simplify field modifications.

● Green = Fastest shipped items ● Black = Normal lead-time items ● Red = Normally long lead-time items

Tray data & loading

Material Type	Tray Series	Width in. (mm)	Depth in. (mm)	UL Cross-Sectional Area	Span ft. (m)	Loading			
						lbs/ft	Deflection Multiplier	(kg/m)	Deflection Multiplier
Aluminum Ventilated	ACC-03	3 (76)	1 ¹ / ₄ (32)	0.40 in ²	5 (1.5)	17	0.020	(26)	0.350
					6 (1.8)	12	0.042	(18)	0.720
					10 (3.0)	4	0.326	(6)	5.600
					12 (3.7)	3	0.676	(4)	12.000
Aluminum Ventilated	ACC-04	4 (101)	1 ³ / ₄ (44)	0.60 in ²	5 (1.5)	46	0.007	(69)	0.130
					6 (1.8)	32	0.015	(48)	0.260
					10 (3.0)	12	0.118	(17)	2.000
					12 (3.7)	8	0.244	(12)	4.200
Aluminum Ventilated	ACC-06	6 (152)	1 ³ / ₄ (44)	0.60 in ²	5 (1.5)	60	0.006	(90)	0.110
					6 (1.8)	42	0.013	(62)	0.230
					10 (3.0)	15	0.102	(22)	1.700
					12 (3.7)	10	0.211	(16)	3.600
Aluminum Non-Ventilated	ACCN-03	3 (76)	1 ¹ / ₄ (32)	0.40 in ²	5 (1.5)	23	0.020	(34)	0.350
					6 (1.8)	16	0.042	(24)	0.720
					10 (3.0)	6	0.326	(9)	5.600
					12 (3.7)	4	0.676	(6)	12.000
Aluminum Non-Ventilated	ACCN-04	4 (101)	1 ³ / ₄ (44)	0.60 in ²	5 (1.5)	46	0.007	(69)	0.130
					6 (1.8)	32	0.015	(48)	0.260
					10 (3.0)	12	0.118	(17)	2.000
					12 (3.7)	8	0.244	(12)	4.200
Aluminum Non-Ventilated	ACCN-06	6 (152)	1 ³ / ₄ (44)	0.60 in ²	5 (1.5)	60	0.006	(90)	0.110
					6 (1.8)	42	0.013	(62)	0.230
					10 (3.0)	15	0.102	(22)	1.700
					12 (3.7)	10	0.211	(16)	3.600
Steel & Stainless Steel Ventilated	PCC-03 SS4CC-03 SS6CC-03	3 (76)	1 ¹ / ₄ (32)	0.20 in ²	5 (1.5)	24	0.013	(36)	0.220
					6 (1.8)	17	0.028	(25)	0.480
					10 (3.0)	6	0.216	(9)	3.700
					12 (3.7)	4	0.447	(6)	7.600
Steel & Stainless Steel Ventilated	PCC-03 SS4CC-03 SS6CC-03	4 (101)	1 ³ / ₄ (44)	0.40 in ²	5 (1.5)	52	0.0039	(77)	0.070
					6 (1.8)	36	0.0082	(54)	0.140
					10 (3.0)	13	0.063	(19)	1.100
					12 (3.7)	9	0.130	(13)	2.200
Steel & Stainless Steel Ventilated	PCC-03 SS4CC-03 SS6CC-03	6 (152)	1 ³ / ₄ (44)	0.40 in ²	5 (1.5)	59	0.003	(88)	0.050
					6 (1.8)	41	0.0063	(61)	0.110
					10 (3.0)	15	0.049	(22)	0.840
					12 (3.7)	10	0.101	(15)	1.700
Steel & Stainless Steel Non-Ventilated	PCCN-03 SS4CCN-03 SS6CCN-03	3 (76)	1 ¹ / ₄ (32)	0.20 in ²	5 (1.5)	24	0.013	(36)	0.220
					6 (1.8)	17	0.028	(25)	0.480
					10 (3.0)	6	0.216	(9)	3.700
					12 (3.7)	4	0.447	(6)	7.600
Steel & Stainless Steel Non-Ventilated	PCCN-03 SS4CCN-03 SS6CCN-03	4 (101)	1 ³ / ₄ (44)	0.40 in ²	5 (1.5)	52	0.0039	(77)	0.070
					6 (1.8)	36	0.0082	(54)	0.140
					10 (3.0)	13	0.063	(19)	1.100
					12 (3.7)	9	0.130	(13)	2.200
Steel & Stainless Steel Non-Ventilated	PCCN-03 SS4CCN-03 SS6CCN-03	6 (152)	1 ³ / ₄ (44)	0.40 in ²	5 (1.5)	59	0.003	(88)	0.050
					6 (1.8)	41	0.0063	(61)	0.110
					10 (3.0)	15	0.049	(22)	0.840
					12 (3.7)	10	0.101	(15)	1.700

Cable Channel

Splice Plate

The Splice Plate has the standard 4-hole pattern for all cable channel.

- Provided with straight sections and fittings. **A G P SS4 SS6**
- Furnished as one plate with hardware.
- (*) Insert

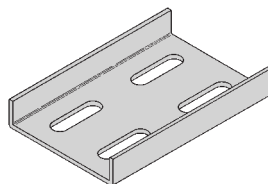

Catalog No.	Channel Width	
	in.	(mm)
9(*)-1043	3	(76)
9(*)-1044	4	(101)
9(*)-1044-6	6	(152)

Horizontal Adjustable Splice Plate

The Horizontal Adjustable Splice Plate adapts to changes in direction in a horizontal plane, beyond the capability of the standard horizontal fittings.

- Furnished as one plate with hardware.
- (*) Insert **A G P SS4 SS6**

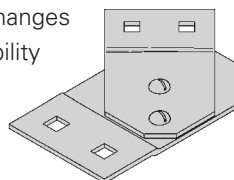

Requires supports within 24" on both sides, per NEMA VE 2.

Catalog No.	Channel Width	
	in.	(mm)
9(*)-1743	3	(76)
9(*)-1744	4	(101)
9(*)-1746	6	(152)

Box Connector

The Box Connector is used to attach the end of a cable channel run to a distribution box or a control center.

- Furnished as one connector with hardware.
- (*) Insert **A G P SS4 SS6**

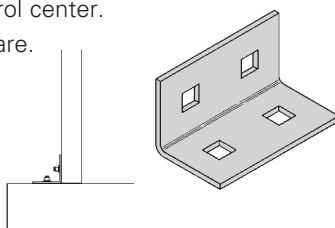

Catalog No.	Channel Width	
	in.	(mm)
9(*)-1543	3	(76)
9(*)-1544	4	(101)
9(*)-1546	6	(152)

Channel Reducer Plate

The Channel Reducer Plate is used to join cable channel sections of different widths.

- Furnished as one plate with hardware.
- (*) Insert **A G P SS4 SS6**

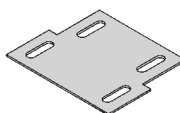

Catalog No.	Channel Width	
	in.	(mm)
9(*)-1843	4 to 3	(101 to 76)
9(*)-1863	6 to 3	(152 to 76)
9(*)-1864	6 to 4	(152 to 101)

Blind End Plate

The Blind End Plate forms a closure for any cable channel dead end.

- Furnished as one plate with hardware.
- (*) Insert **A G P SS4 SS6**

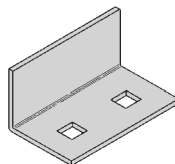

Catalog No.	Channel Width	
	in.	(mm)
9(*)-1583	3	(76)
9(*)-1584	4	(101)
9(*)-1586	6	(152)

● Green = Fastest shipped items ● Black = Normal lead-time items ● Red = Normally long lead-time items

All dimensions in shaded areas are millimeters unless otherwise specified.

Vertical Adjustable Splice Plate

The Adjustable Splice Plate allows changes in elevation where standard vertical fittings are not applicable.

- Furnished as one plate with hardware.
- (*) Insert **A G P SS4 SS6**

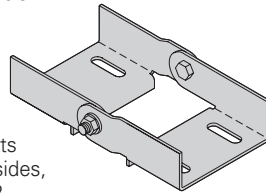

Requires supports within 24" on both sides, per NEMA VE 2.

Catalog No.	Channel Width	
	in.	(mm)
9(*)-1643	3	(76)
9(*)-1644	4	(101)
9(*)-1646	6	(152)

Channel To Tray or Channel To Channel Connector

The Channel Connector is used to link a cable channel to a cable tray, or a cable channel to cable channel.

- Furnished as one plate with hardware.
- (*) Insert **A G P SS4 SS6**

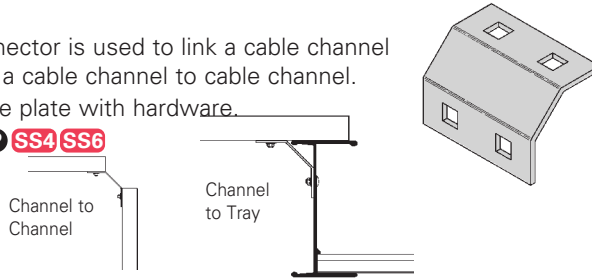

Catalog No.	Channel Width	
	in.	(mm)
9(*)-1261-3	3	(76)
9(*)-1261-4	4	(101)
9(*)-1261-6	6	(152)

Mounting Bracket - Channel To Tray

The Mounting Bracket allows a parallel run of cable channel to be attached to the side of a cable tray. It can also serve as a support splice connection.

- Furnished as one bracket.
- Order hardware separately.
- (*) Insert **A G ZN SS4 SS6**

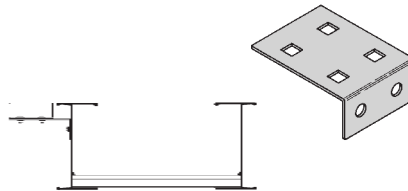

Catalog No.	Channel Width	
	in.	(mm)
9(*)-1237-3	3	(76)
9(*)-1237-4	4	(101)
9(*)-1237-6	6	(152)

Expansion Guide Clamp

The Expansion Guide Clamp allows cable channel to expand and contract in the horizontal plane, but not in the transverse plane.

- Furnished as one clamp.
- Order 1/2" hardware separately.
- (*) Insert **A G ZN SS4 SS6**

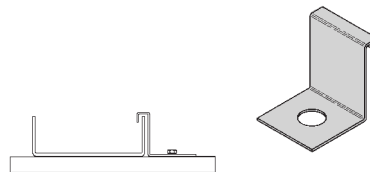

Catalog No.	Channel Width	
	in.	(mm)
9(*)-1243	3	(76)
9(*)-1244	4	(101)
9(*)-1244	6	(152)

Hold-Down Clamp

The Hold-Down Clamp secures cable channel to a support member.

- Furnished as one clamp.
- Order 1/2" hardware separately.
- (*) Insert **A G ZN SS4 SS6**

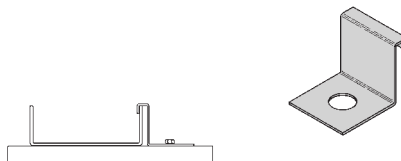

Catalog No.	Channel Width	
	in.	(mm)
9(*)-1245	3	(76)
9(*)-1246	4	(101)
9(*)-1246	6	(152)

● Green = Fastest shipped items ● Black = Normal lead-time items ● Red = Normally long lead-time items

All dimensions in shaded areas are millimeters unless otherwise specified.

Channel To Floor Base Plate

The Channel to Floor Base Plate is used to attach the end of a cable channel run to the floor or to an equipment mounting pad.

- Anchors and hardware are ordered separately.
- (*) Insert **A** **G** **ZN** **SS4** **SS6**

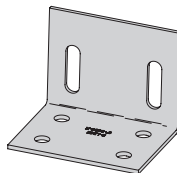

Catalog No.	Channel Width	
	in.	(mm)
9(*)-3305-3	3	(76)
9(*)-3305-4	4	(101)
9(*)-3305-6	6	(152)

Cable Channel Bushing

The Cable Channel Bushing is a snap-in plastic bushing used to protect cable insulation from mechanical wear.

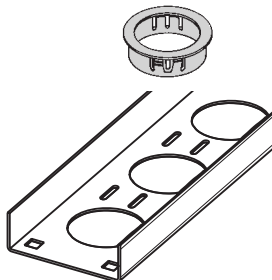

Catalog No.
99-1125

Cable Channel Bracket

- Uniform Load: 225 lbs (1.00 kN) Safety Factor of 2.5
- Finishes available: **ZN** **G**

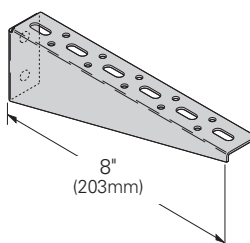

Catalog No.	Channel Width	
	in.	(mm)
B185CCL	3 to 6	(76 to 152)

Cable Channel Bracket

- Safety Factor of 2.5
- Finishes available: **ZN** **G** **GRN**

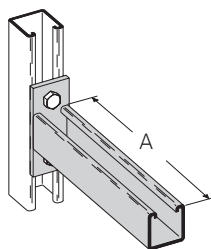

Catalog No.	Channel Width		Uniform Load		A	
	in.	(mm)	lbs	(kN)	in.	(mm)
B409-6	3	(76)	1920	(8.54)	6	(152)
B409-9	4, 6	(101, 152)	1280	(5.69)	9	(228)

Cable Channel Hanger

Designed for 1/2" threaded rod, double nut installation

Single Cable Channel Hanger and Wall Mount

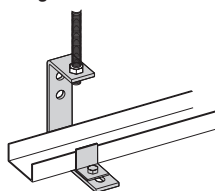

150 lb.
Safety Factor 3.0

Material	Channel Width		
	in. (mm)	in. (mm)	in. (mm)
	3 (76)	4 (101)	6 (152)
Zinc Plated Steel			
Double Channel	● 9ZN-1232-3	● 9ZN-1232-4	● 9ZN-1232-6
Single Channel	● 9ZN-1231-3 & 4	● 9ZN-1231-3 & 4	● 9ZN-1231-6
HDGAF Steel (18 Ga.)			
Double Channel	● 9G-1232-3	● 9G-1232-4	● 9G-1232-6
Single Channel	● 9G-1231-3 & 4	● 9G-1231-3 & 4	● 9G-1231-6

Double Cable Channel Hanger

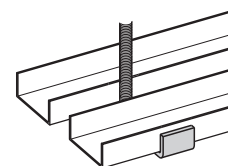

265 lb.
Safety Factor 3.0

● Green = Fastest shipped items ● Black = Normal lead-time items ● Red = Normally long lead-time items

All dimensions in shaded areas are millimeters unless otherwise specified.

Cable Channel Covers

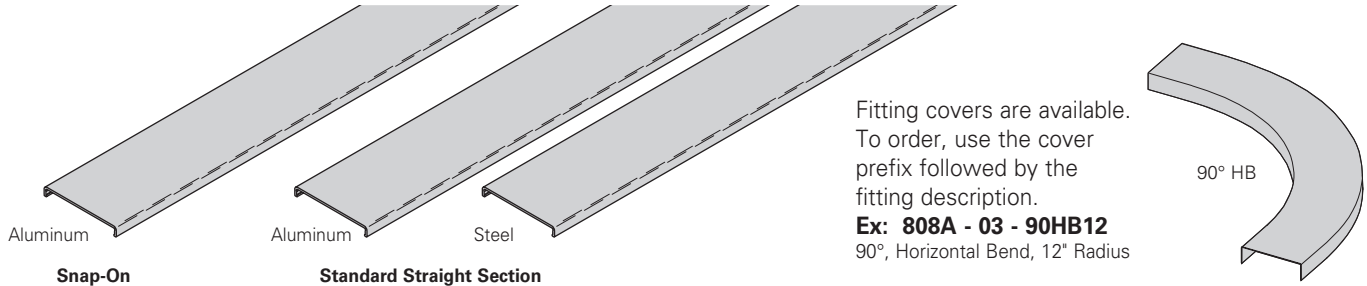

Covers Part Numbering

Prefix
 Example: **80 8 S A - 04 - 144**

Cover Type 80 = Solid	Detail 8 = Flanged	Style S = Snap-On (Aluminum only*) __ = Standard	Material ● A = Aluminum ● G = Type 1 HDGAF ● P = Type 2 Pre-Galvanized ● SS4 = 304 Stainless Steel ● SS6 = 316 Stainless Steel	Tray Width ● 03 = 3" ● 04 = 4" ● 06 = 6"	Item Description For Straight Section Cover: Pre-Galv & Aluminum Only: 144 = 12 ft. 120 = 10 ft. Pre-Galv, HDGAF & Alum 72 = 6 ft.* 60 = 5 ft.* Insert suffix of fitting to be covered from the fitting's page. __HB__ = Horizontal Bend HT__ = Horizontal Tee HX__ = Horizontal Cross __VI__ = Vertical Inside Bend __VO__ = Vertical Outside Bend
---------------------------------	------------------------------	---	--	--	---

All items normal lead time except for those indicated

Material	Length ft (m)	Channel Width - Straight Section Part Number			
		in. (mm)	in. (mm)	in. (mm)	
● Aluminum (.032) Solid	12 3.56m	3 (76)	4 (101)	6 (152)	
	10 3.05m	808A-03-144	808A-04-144	808A-06-144	
● Type II Pre-Galvanized Steel (20 Ga.) Solid	12 3.56m	3 (76)	4 (101)	6 (152)	
	10 3.05m	808P-03-144	808P-04-144	808P-06-144	
● Type I Hot Dip Galvanized Steel (18 Ga.) Solid	12 3.56m	3 (76)	4 (101)	6 (152)	
	10 3.05m	808G-03-72	808G-04-72	808G-06-72	
			808G-03-60	808G-04-60	808G-06-60

Wrap-Around Cover Clamp

Wrap-Around Cover Clamps are used to securely hold a cover on cable channel in locations where strong winds can prevail.

- Furnished as one clamp with hardware.
- (*) Insert **A G P SS4 SS6**

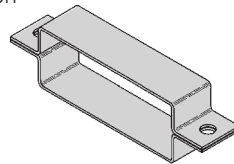

Catalog No.	Channel Width in. (mm)
9(*)-9033	3 (76)
9(*)-9034	4 (101)
9(*)-9036	6 (152)

Combination Hold-Down & Cover Clamp

This clamp is used to hold both the cable channel and cover in place at the same time.

- Furnished as one clamp.
- Order 1/4" hardware separately.
- (*) Insert **A G P SS6**

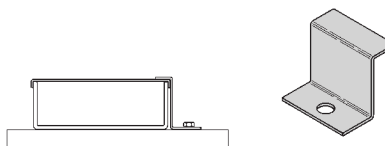

Catalog No.	Channel Width in. (mm)
9(*)-9023	3 (76)
9(*)-9024	4 (101)
9(*)-9024	6 (152)

● Green = Fastest shipped items ● Black = Normal lead-time items ● Red = Normally long lead-time items

All dimensions in shaded areas are millimeters unless otherwise specified.

Channel Cable Tray Connectors

Fast, economical, space saving Channel Cable Tray Connectors
 Patent No. 5,628,481; 5,782,439. Other patents pending.

Horizontal:

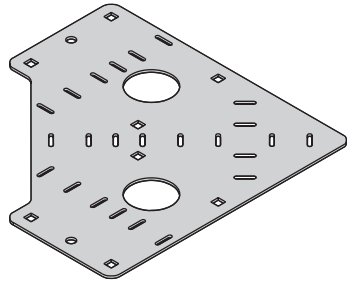

90° Bend

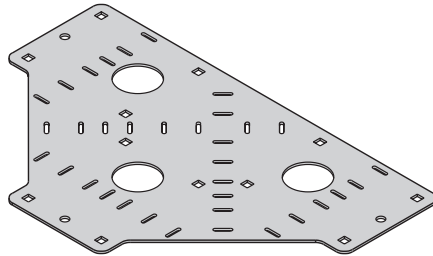

Tee

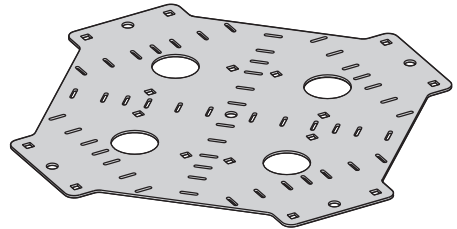
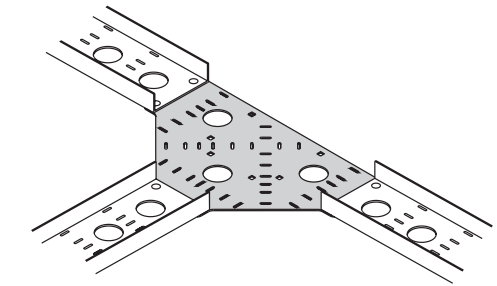

Cross

- Provides 0 or 6-inch radius connection for Cable Channel
- The Pivot Connector is available for custom angle adjustment
 - up to +/- 45° angle adjustment
 - order the desired quantity separately
- Slotted for easy cable fastening
- Shipped with the required hardware

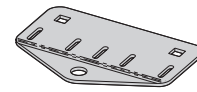

Pivot Connector

Vertical:

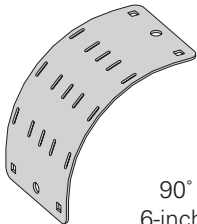

90° Bend
6-inch radius

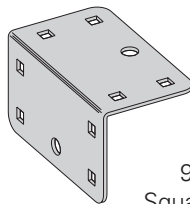

90° Vertical
Square Connector
0-inch radius

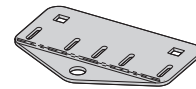

Pivot
Connector

- Use the same part for VO and VI applications
- Slotted for easy cable fastening
- The Pivot Connector is available for custom angle adjustment (order separately)
- Shipped with the required hardware

Connector Part Numbering

Example: **A CC - 04 - 90HC 060**

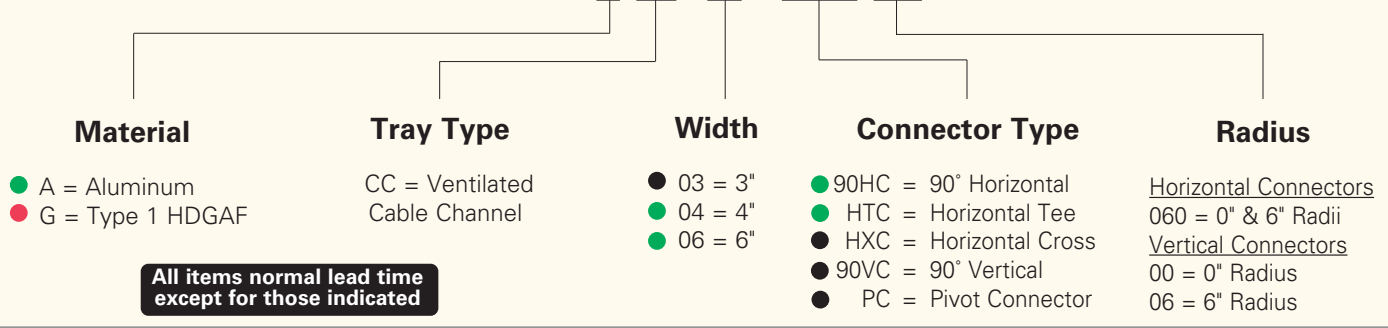

● Green = Fastest shipped items ● Black = Normal lead-time items ● Red = Normally long lead-time items

All dimensions in shaded areas are millimeters unless otherwise specified.

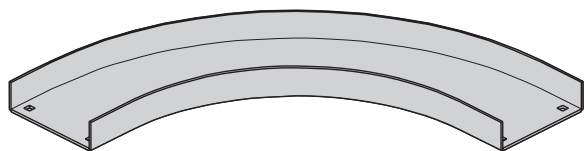

ACCN-04-90HB12
Non-Ventilated Horizontal Bend

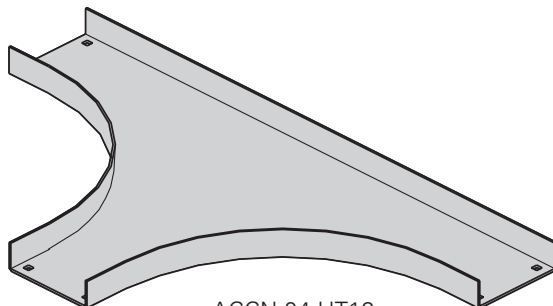

ACCN-04-HT12
Non-Ventilated Tee

Fittings engineered with 3" tangents for splicing integrity.

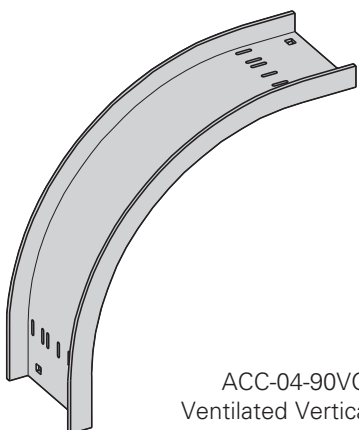

ACC-04-90VO12
Ventilated Vertical Bend

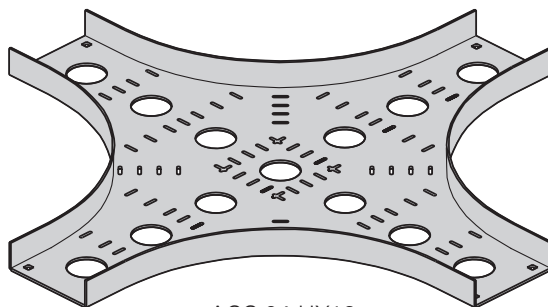

ACC-04-HX12
Ventilated Horizontal Cross

Fittings Part Numbering

Example: **A CCN - 04 - 90 HB 24**

Material

- A = Aluminum
- G = Type 1 HDGAF
- SS4 = 304 Stainless Steel
- SS6 = 316 Stainless Steel
- P = †

Tray Type

- *CC = Ventilated Cable Channel
- CCN = Non-ventilated Cable Channel

Width

- 03 = 3"
- 04 = 4"
- 06 = 6"

Angle

- 30 = 30°
- 45 = 45°
- 60 = 60°
- 90 = 90°

Fitting Type

- HB = Horizontal Bend
- HT = Horizontal Tee
- HX = Horizontal Cross
- VI = Vertical Inside Bend
- VO = Vertical Outside Bend

Radius

- 12 = 12"
- 24 = 24"
- 36 = 36"
- 48 = 48"

* Ventilated Cable Channel Fittings are available only in 12" and 24" radii.

† - Due to multiple piece welded construction, P fittings are not available - substitute G.

All items normal lead time except for those indicated

● Green = Fastest shipped items ● Black = Normal lead-time items ● Red = Normally long lead-time items

All dimensions in shaded areas are millimeters unless otherwise specified.

Horizontal Bends 90°, 60° (HB)

1 splice plate with hardware included.

Bend Radius R in. (mm)	Tray Width in. (mm)	90° Horizontal Bend Dimensions			
		Catalog No.	A in. (mm)	B in. (mm)	C in. (mm)
12 (305)	3 (76)	(Pre)-03-90HB12	16 ¹ / ₂ (419)	16 ¹ / ₂ (419)	16 ¹ / ₂ (419)
	4 (101)	(Pre)-04-90HB12	17 (432)	17 (432)	17 (432)
	6 (152)	(Pre)-06-90HB12	18 (457)	18 (457)	18 (457)
24 (609)	3 (76)	(Pre)-03-90HB24	28 ¹ / ₂ (723)	28 ¹ / ₂ (723)	28 ¹ / ₂ (723)
	4 (101)	(Pre)-04-90HB24	29 (737)	29 (737)	29 (737)
	6 (152)	(Pre)-06-90HB24	30 (762)	30 (762)	30 (762)
36 (915)	3 (76)	(Pre)-03-90HB36	40 ¹ / ₂ (1029)	40 ¹ / ₂ (1029)	40 ¹ / ₂ (1029)
	4 (101)	(Pre)-04-90HB36	41 (1041)	41 (1041)	41 (1041)
	6 (152)	(Pre)-06-90HB36	42 (1067)	42 (1067)	42 (1067)
48 (1218)	3 (76)	(Pre)-03-90HB48	52 ¹ / ₂ (1334)	52 ¹ / ₂ (1334)	52 ¹ / ₂ (1334)
	4 (101)	(Pre)-04-90HB48	53 (1346)	53 (1346)	53 (1346)
	6 (152)	(Pre)-06-90HB48	54 (1372)	54 (1372)	54 (1372)

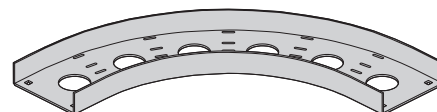

90° Horizontal Bend
Ventilated Horizontal Bend

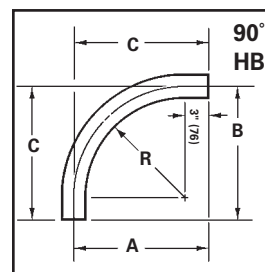

60° Horizontal Bend					
12 (305)	3 (76)	(Pre)-03-60HB12	16 ¹ / ₄ (412)	9 ³ / ₈ (239)	10 ³ / ₄ (273)
	4 (101)	(Pre)-04-60HB12	16 ⁵ / ₈ (422)	9 ⁵ / ₈ (245)	11 ¹ / ₈ (283)
	6 (152)	(Pre)-06-60HB12	17 ¹ / ₂ (445)	10 (254)	11 ⁵ / ₈ (296)
24 (609)	3 (76)	(Pre)-03-60HB24	26 ⁵ / ₈ (676)	15 ³ / ₈ (391)	17 ³ / ₄ (451)
	4 (101)	(Pre)-04-60HB24	27 (686)	15 ⁵ / ₈ (397)	18 (450)
	6 (152)	(Pre)-06-60HB24	27 ⁷ / ₈ (708)	16 (406)	18 ⁵ / ₈ (466)
36 (915)	3 (76)	(Pre)-03-60HB36	37 (940)	21 ³ / ₈ (543)	24 ⁵ / ₈ (625)
	4 (101)	(Pre)-04-60HB36	37 ³ / ₈ (949)	21 ⁵ / ₈ (549)	25 (635)
	6 (152)	(Pre)-06-60HB36	38 ¹ / ₄ (972)	22 (559)	25 ¹ / ₂ (648)
48 (1218)	3 (76)	(Pre)-03-60HB48	47 ³ / ₈ (1203)	27 ³ / ₈ (695)	31 ⁵ / ₈ (803)
	4 (101)	(Pre)-04-60HB48	47 ⁷ / ₈ (1216)	27 ⁵ / ₈ (702)	31 ⁷ / ₈ (810)
	6 (152)	(Pre)-06-60HB48	48 ⁵ / ₈ (1235)	28 (711)	32 ¹ / ₂ (826)

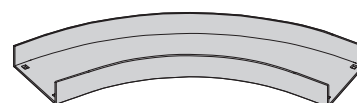

60° Horizontal Bend
Non-Ventilated Horizontal Bend

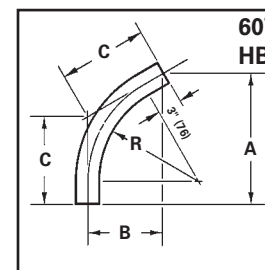

(Pre) See page E-10 for catalog number prefix.

Horizontal Bends 45°, 30° (HB)

1 splice plate with hardware included.

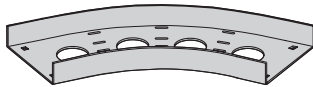

45° Horizontal Bend
Ventilated Horizontal Bend

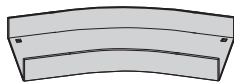
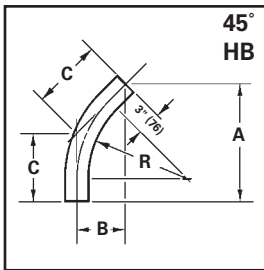

30° Horizontal Bend
Non-Ventilated Horizontal Bend

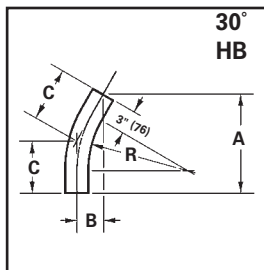

Bend Radius R in. (mm)	Tray Width in. (mm)	45° Horizontal Bend Dimensions			
		Catalog No.	A in. (mm)	B in. (mm)	C in. (mm)
12 (305)	3 (76)	(Pre)-03-45HB12	14 ⁵ / ₈ (371)	6 ¹ / ₈ (156)	8 ⁵ / ₈ (219)
	4 (101)	(Pre)-04-45HB12	15 (381)	6 ¹ / ₄ (159)	8 ⁷ / ₈ (225)
	6 (152)	(Pre)-06-45HB12	15 ³ / ₄ (400)	6 ¹ / ₂ (165)	9 ¹ / ₄ (235)
24 (609)	3 (76)	(Pre)-03-45HB24	23 ¹ / ₈ (587)	9 ⁵ / ₈ (244)	13 ⁵ / ₈ (346)
	4 (101)	(Pre)-04-45HB24	23 ¹ / ₂ (597)	9 ³ / ₄ (248)	13 ³ / ₄ (349)
	6 (152)	(Pre)-06-45HB24	24 ¹ / ₈ (613)	10 (254)	14 ¹ / ₈ (359)
36 (915)	3 (76)	(Pre)-03-45HB36	31 ⁵ / ₈ (803)	13 ¹ / ₈ (334)	18 ⁵ / ₈ (473)
	4 (101)	(Pre)-04-45HB36	32 (813)	13 ¹ / ₄ (337)	18 ³ / ₄ (476)
	6 (152)	(Pre)-06-45HB36	32 ³ / ₄ (832)	13 ¹ / ₂ (343)	19 ¹ / ₈ (486)
48 (1218)	3 (76)	(Pre)-03-45HB48	40 ¹ / ₈ (1019)	16 ⁵ / ₈ (422)	23 ¹ / ₂ (597)
	4 (101)	(Pre)-04-45HB48	40 ¹ / ₂ (1029)	16 ³ / ₄ (425)	23 ³ / ₄ (603)
	6 (152)	(Pre)-06-45HB48	41 ¹ / ₈ (1045)	17 (432)	24 ¹ / ₈ (613)

30° Horizontal Bend					
Bend Radius R in. (mm)	Tray Width in. (mm)	30° Horizontal Bend Dimensions			
		Catalog No.	A in. (mm)	B in. (mm)	C in. (mm)
12 (305)	3 (76)	(Pre)-03-30HB12	12 ³ / ₈ (314)	3 ¹ / ₄ (83)	6 ⁵ / ₈ (168)
	4 (101)	(Pre)-04-30HB12	12 ⁵ / ₈ (321)	3 ³ / ₈ (86)	6 ³ / ₄ (171)
	6 (152)	(Pre)-06-30HB12	13 ¹ / ₈ (334)	3 ¹ / ₂ (89)	7 (178)
24 (609)	3 (76)	(Pre)-03-30HB24	18 ³ / ₈ (467)	4 ⁷ / ₈ (124)	9 ⁷ / ₈ (251)
	4 (101)	(Pre)-04-30HB24	18 ⁵ / ₈ (473)	5 (127)	10 (254)
	6 (152)	(Pre)-06-30HB24	19 ¹ / ₈ (486)	5 ¹ / ₈ (130)	10 ¹ / ₄ (260)
36 (915)	3 (76)	(Pre)-03-30HB36	24 ³ / ₈ (619)	6 ¹ / ₂ (165)	13 (330)
	4 (101)	(Pre)-04-30HB36	24 ⁵ / ₈ (626)	6 ⁵ / ₈ (168)	13 ¹ / ₈ (334)
	6 (152)	(Pre)-06-30HB36	25 ¹ / ₈ (638)	6 ³ / ₄ (171)	13 ¹ / ₂ (343)
48 (1218)	3 (76)	(Pre)-03-30HB48	30 ³ / ₈ (772)	8 ¹ / ₈ (207)	16 ¹ / ₄ (413)
	4 (101)	(Pre)-04-30HB48	30 ⁵ / ₈ (778)	8 ¹ / ₄ (210)	16 ³ / ₈ (416)
	6 (152)	(Pre)-06-30HB48	31 ¹ / ₈ (791)	8 ³ / ₈ (213)	16 ⁵ / ₈ (422)

(Pre) See page E-10 for catalog number prefix.

All dimensions in shaded areas are millimeters unless otherwise specified.

Horizontal Tee (HT)

2 splice plates with hardware included.

Bend Radius R in. (mm)	Tray Width in. (mm)	Horizontal Tee Dimensions		
		Catalog No.	A in. (mm)	B in. (mm)
12 (305)	3 (76)	(Pre)-03-HT12	16 ¹ / ₂ (419)	33 (838)
	4 (101)	(Pre)-04-HT12	17 (432)	34 (864)
	6 (152)	(Pre)-06-HT12	18 (457)	36 (914)
24 (609)	3 (76)	(Pre)-03-HT24	28 ¹ / ₂ (723)	57 (1448)
	4 (101)	(Pre)-04-HT24	29 (737)	58 (1473)
	6 (152)	(Pre)-06-HT24	30 (762)	60 (1524)
36 (915)	3 (76)	(Pre)-03-HT36	40 ¹ / ₂ (1029)	81 (2057)
	4 (101)	(Pre)-04-HT36	41 (1041)	82 (2083)
	6 (152)	(Pre)-06-HT36	42 (1067)	84 (2134)
48 (1218)	3 (76)	(Pre)-03-HT48	52 ¹ / ₂ (1334)	105 (2667)
	4 (101)	(Pre)-04-HT48	53 (1346)	106 (2692)
	6 (152)	(Pre)-06-HT48	54 (1372)	108 (2743)

(Pre) See page E-10 for catalog number prefix.

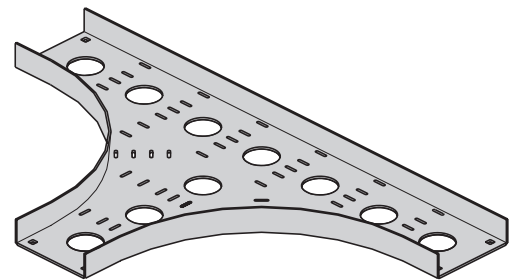

Horizontal Tee
Ventilated Horizontal Tee

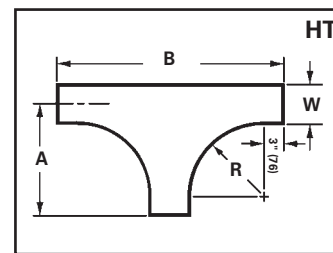

Horizontal Cross (HX)

3 splice plates with hardware included.

Bend Radius R in. (mm)	Tray Width in. (mm)	Horizontal Cross Dimensions		
		Catalog No.	A in. (mm)	B in. (mm)
12 (305)	3 (76)	(Pre)-03-HX12	16 ¹ / ₂ (419)	33 (838)
	4 (101)	(Pre)-04-HX12	17 (432)	34 (864)
	6 (152)	(Pre)-06-HX12	18 (457)	36 (914)
24 (609)	3 (76)	(Pre)-03-HX24	28 ¹ / ₂ (723)	57 (1448)
	4 (101)	(Pre)-04-HX24	29 (737)	58 (1473)
	6 (152)	(Pre)-06-HX24	30 (762)	60 (1524)
36 (915)	3 (76)	(Pre)-03-HX36	40 ¹ / ₂ (1029)	81 (2057)
	4 (101)	(Pre)-04-HX36	41 (1041)	82 (2083)
	6 (152)	(Pre)-06-HX36	42 (1067)	84 (2134)
48 (1218)	3 (76)	(Pre)-03-HX48	52 ¹ / ₂ (1334)	105 (2667)
	4 (101)	(Pre)-04-HX48	53 (1346)	106 (2692)
	6 (152)	(Pre)-06-HX48	54 (1372)	108 (2743)

(Pre) See page E-10 for catalog number prefix.

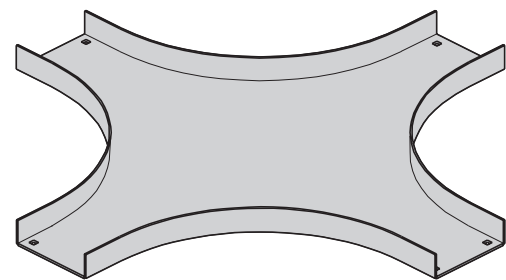

Horizontal Cross
Non-Ventilated Horizontal Cross

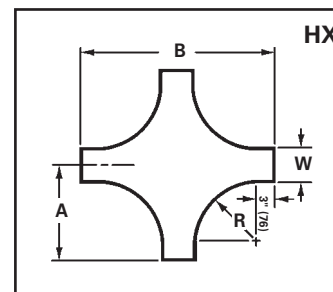

All dimensions in shaded areas are millimeters unless otherwise specified.

Vertical Outside Bends 90°, 60° (VO)

1 splice plate with hardware included.

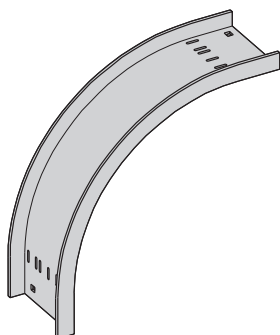

90° Vertical Outside Bend
Ventilated Vertical Outside Bend

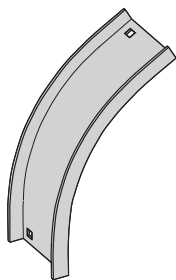
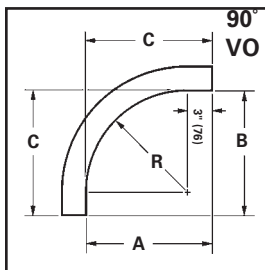

60° Vertical Outside Bend
Non-Ventilated Vertical Outside Bend

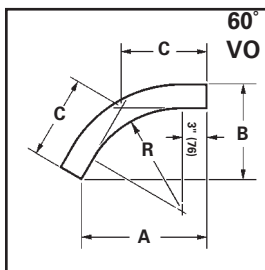

Bend Radius R in. (mm)	Tray Width in. (mm)	90° Vertical Outside Bend Dimensions			
		Catalog No.	A in. (mm)	B in. (mm)	C in. (mm)
12 (305)	3 (76)	(Pre)-03-90VO12	15 (381)	15 (381)	15 (381)
	4 (101)	(Pre)-04-90VO12	15 (381)	15 (381)	15 (381)
	6 (152)	(Pre)-06-90VO12	15 (381)	15 (381)	15 (381)
24 (609)	3 (76)	(Pre)-03-90VO24	27 (686)	27 (686)	27 (686)
	4 (101)	(Pre)-04-90VO24	27 (686)	27 (686)	27 (686)
	6 (152)	(Pre)-06-90VO24	27 (686)	27 (686)	27 (686)
36 (915)	3 (76)	(Pre)-03-90VO36	39 (991)	39 (991)	39 (991)
	4 (101)	(Pre)-04-90VO36	39 (991)	39 (991)	39 (991)
	6 (152)	(Pre)-06-90VO36	39 (991)	39 (991)	39 (991)
48 (1218)	3 (76)	(Pre)-03-90VO48	51 (1295)	51 (1295)	51 (1295)
	4 (101)	(Pre)-04-90VO48	51 (1295)	51 (1295)	51 (1295)
	6 (152)	(Pre)-06-90VO48	51 (1295)	51 (1295)	51 (1295)

60° Vertical Outside Bend					
Bend Radius R in. (mm)	Tray Width in. (mm)	Catalog No.	A in. (mm)	B in. (mm)	C in. (mm)
12 (305)	3 (76)	(Pre)-03-60VO12	14 ⁷ / ₈ (378)	8 ¹ / ₂ (216)	9 ⁷ / ₈ (251)
	4 (101)	(Pre)-04-60VO12	14 ⁷ / ₈ (378)	8 ¹ / ₂ (216)	9 ⁷ / ₈ (251)
	6 (152)	(Pre)-06-60VO12	14 ⁷ / ₈ (378)	8 ¹ / ₂ (216)	9 ⁷ / ₈ (251)
24 (609)	3 (76)	(Pre)-03-60VO24	25 ³ / ₈ (645)	14 ⁵ / ₈ (372)	16 ⁷ / ₈ (428)
	4 (101)	(Pre)-04-60VO24	25 ³ / ₈ (645)	14 ⁵ / ₈ (372)	16 ⁷ / ₈ (428)
	6 (152)	(Pre)-06-60VO24	25 ³ / ₈ (645)	14 ⁵ / ₈ (372)	16 ⁷ / ₈ (428)
36 (915)	3 (76)	(Pre)-03-60VO36	35 ³ / ₈ (905)	20 ⁵ / ₈ (524)	23 ³ / ₄ (603)
	4 (101)	(Pre)-04-60VO36	35 ³ / ₈ (905)	20 ⁵ / ₈ (524)	23 ³ / ₄ (603)
	6 (152)	(Pre)-06-60VO36	35 ³ / ₈ (905)	20 ⁵ / ₈ (524)	23 ³ / ₄ (603)
48 (1218)	3 (76)	(Pre)-03-60VO48	46 ¹ / ₈ (1172)	26 ⁵ / ₈ (676)	30 ³ / ₄ (781)
	4 (101)	(Pre)-04-60VO48	46 ¹ / ₈ (1172)	26 ⁵ / ₈ (676)	30 ³ / ₄ (781)
	6 (152)	(Pre)-06-60VO48	46 ¹ / ₈ (1172)	26 ⁵ / ₈ (676)	30 ³ / ₄ (781)

(Pre) See page E-10 for catalog number prefix.

All dimensions in shaded areas are millimeters unless otherwise specified.

Vertical Outside Bends 45°, 30° (VO)

1 splice plate with hardware included.

Bend Radius R	Tray Width	45° Vertical Outside Bend Dimensions			
		Catalog No.	A	B	C
in. (mm)	in. (mm)		in. (mm)	in. (mm)	in. (mm)
12 (305)	3 (76)	(Pre)-03-45VO12	13 ⁵ / ₈ (346)	5 ⁵ / ₈ (143)	8 (203)
	4 (101)	(Pre)-04-45VO12	13 ⁵ / ₈ (346)	5 ⁵ / ₈ (143)	8 (203)
	6 (152)	(Pre)-06-45VO12	13 ⁵ / ₈ (346)	5 ⁵ / ₈ (143)	8 (203)
24 (609)	3 (76)	(Pre)-03-45VO24	22 ¹ / ₄ (565)	9 ¹ / ₄ (235)	13 (330)
	4 (101)	(Pre)-04-45VO24	22 ¹ / ₄ (565)	9 ¹ / ₄ (235)	13 (330)
	6 (152)	(Pre)-06-45VO24	22 ¹ / ₄ (565)	9 ¹ / ₄ (235)	13 (330)
36 (915)	3 (76)	(Pre)-03-45VO36	30 ¹ / ₂ (775)	12 ⁵ / ₈ (321)	17 ⁷ / ₈ (454)
	4 (101)	(Pre)-04-45VO36	30 ¹ / ₂ (775)	12 ⁵ / ₈ (321)	17 ⁷ / ₈ (454)
	6 (152)	(Pre)-06-45VO36	30 ¹ / ₂ (775)	12 ⁵ / ₈ (321)	17 ⁷ / ₈ (454)
48 (1218)	3 (76)	(Pre)-03-45VO48	39 (991)	16 ¹ / ₈ (410)	22 ⁷ / ₈ (581)
	4 (101)	(Pre)-04-45VO48	39 (991)	16 ¹ / ₈ (410)	22 ⁷ / ₈ (581)
	6 (152)	(Pre)-06-45VO48	39 (991)	16 ¹ / ₈ (410)	22 ⁷ / ₈ (581)

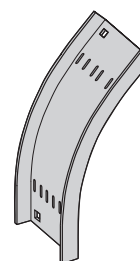

45° Vertical Outside Bend
Ventilated Vertical Outside Bend

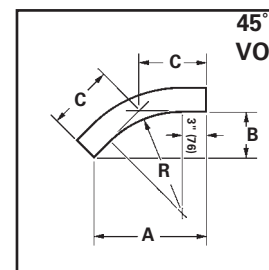

30° Vertical Outside Bend					
12 (305)	3 (76)	(Pre)-03-30VO12	11 ⁵ / ₈ (296)	3 ¹ / ₈ (79)	6 ¹ / ₄ (158)
	4 (101)	(Pre)-04-30VO12	11 ⁵ / ₈ (296)	3 ¹ / ₈ (79)	6 ¹ / ₄ (158)
	6 (152)	(Pre)-06-30VO12	11 ⁵ / ₈ (296)	3 ¹ / ₈ (79)	6 ¹ / ₄ (158)
24 (609)	3 (76)	(Pre)-03-30VO24	17 ¹ / ₂ (445)	4 ⁷ / ₈ (124)	9 ³ / ₈ (238)
	4 (101)	(Pre)-04-30VO24	17 ¹ / ₂ (445)	4 ⁷ / ₈ (124)	9 ³ / ₈ (238)
	6 (152)	(Pre)-06-30VO24	17 ¹ / ₂ (445)	4 ⁷ / ₈ (124)	9 ³ / ₈ (238)
36 (915)	3 (76)	(Pre)-03-30VO36	23 ¹ / ₂ (597)	6 ³ / ₈ (162)	12 ⁵ / ₈ (321)
	4 (101)	(Pre)-04-30VO36	23 ¹ / ₂ (597)	6 ³ / ₈ (162)	12 ⁵ / ₈ (321)
	6 (152)	(Pre)-06-30VO36	23 ¹ / ₂ (597)	6 ³ / ₈ (162)	12 ⁵ / ₈ (321)
48 (1218)	3 (76)	(Pre)-03-30VO48	29 ⁵ / ₈ (753)	8 (203)	15 ⁷ / ₈ (403)
	4 (101)	(Pre)-04-30VO48	29 ⁵ / ₈ (753)	8 (203)	15 ⁷ / ₈ (403)
	6 (152)	(Pre)-06-30VO48	29 ⁵ / ₈ (753)	8 (203)	15 ⁷ / ₈ (403)

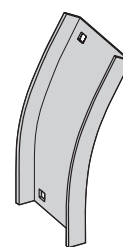

30° Vertical Outside Bend
Non-Ventilated Vertical Outside Bend

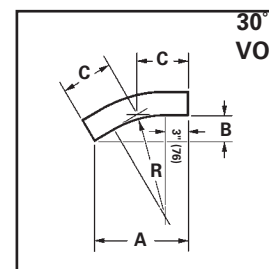

(Pre) See page E-10 for catalog number prefix.

All dimensions in shaded areas are millimeters unless otherwise specified.

Vertical Inside Bends 90°, 60° (VI)

1 splice plate with hardware included.

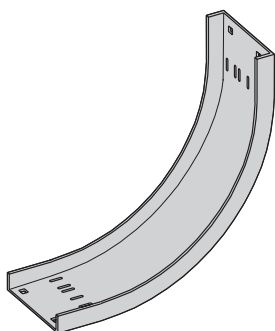

90° Vertical Inside Bend
Ventilated Vertical Inside Bend

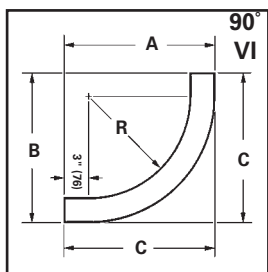

60° Vertical Inside Bend
Non-Ventilated Vertical Inside Bend

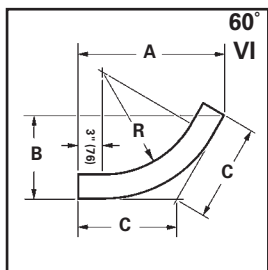

Bend Radius R	Tray Width	90° Vertical Inside Bend			
		Dimensions			
in. (mm)	in. (mm)	Catalog No.	A in. (mm)	B in. (mm)	C in. (mm)
12 (305)	3 (76)	(Pre)-03-90VI12	16 ¹ / ₄ (413)	16 ¹ / ₄ (413)	16 ¹ / ₄ (413)
	4 (101)	(Pre)-04-90VI12	16 ³ / ₄ (425)	16 ³ / ₄ (425)	16 ³ / ₄ (425)
	6 (152)	(Pre)-06-90VI12	16 ³ / ₄ (425)	16 ³ / ₄ (425)	16 ³ / ₄ (425)
24 (609)	3 (76)	(Pre)-03-90VI24	28 ¹ / ₄ (718)	28 ¹ / ₄ (718)	28 ¹ / ₄ (718)
	4 (101)	(Pre)-04-90VI24	28 ³ / ₄ (730)	28 ³ / ₄ (730)	28 ³ / ₄ (730)
	6 (152)	(Pre)-06-90VI24	28 ³ / ₄ (730)	28 ³ / ₄ (730)	28 ³ / ₄ (730)
36 (915)	3 (76)	(Pre)-03-90VI36	40 ¹ / ₄ (1024)	40 ¹ / ₄ (1024)	40 ¹ / ₄ (1024)
	4 (101)	(Pre)-04-90VI36	40 ³ / ₄ (1035)	40 ³ / ₄ (1035)	40 ³ / ₄ (1035)
	6 (152)	(Pre)-06-90VI36	40 ³ / ₄ (1035)	40 ³ / ₄ (1035)	40 ³ / ₄ (1035)
48 (1218)	3 (76)	(Pre)-03-90VI48	52 ¹ / ₄ (1327)	52 ¹ / ₄ (1327)	52 ¹ / ₄ (1327)
	4 (101)	(Pre)-04-90VI48	52 ³ / ₄ (1340)	52 ³ / ₄ (1340)	52 ³ / ₄ (1340)
	6 (152)	(Pre)-06-90VI48	52 ³ / ₄ (1340)	52 ³ / ₄ (1340)	52 ³ / ₄ (1340)

60° Vertical Inside Bend					
Bend Radius R	Tray Width	Catalog No.	A in. (mm)	B in. (mm)	C in. (mm)
12 (305)	3 (76)	(Pre)-03-60VI12	16 (406)	9 ¹ / ₄ (235)	10 ⁵ / ₈ (270)
	4 (101)	(Pre)-04-60VI12	16 ¹ / ₂ (419)	9 ¹ / ₂ (241)	11 (280)
	6 (152)	(Pre)-06-60VI12	16 ¹ / ₂ (419)	9 ¹ / ₂ (241)	11 (280)
24 (609)	3 (76)	(Pre)-03-60VI24	26 ¹ / ₂ (673)	15 ¹ / ₄ (387)	17 ⁵ / ₈ (448)
	4 (101)	(Pre)-04-60VI24	26 ⁷ / ₈ (683)	15 ¹ / ₂ (394)	17 ⁷ / ₈ (454)
	6 (152)	(Pre)-06-60VI24	26 ⁷ / ₈ (683)	15 ¹ / ₂ (394)	17 ⁷ / ₈ (454)
36 (915)	3 (76)	(Pre)-03-60VI36	36 ³ / ₄ (933)	21 ¹ / ₄ (540)	24 ¹ / ₂ (622)
	4 (101)	(Pre)-04-60VI36	37 ¹ / ₈ (943)	21 ³ / ₈ (543)	24 ³ / ₄ (629)
	6 (152)	(Pre)-06-60VI36	37 ¹ / ₈ (943)	21 ³ / ₈ (543)	24 ³ / ₄ (629)
48 (1218)	3 (76)	(Pre)-03-60VI48	47 ¹ / ₈ (1197)	27 ¹ / ₈ (689)	31 ³ / ₈ (797)
	4 (101)	(Pre)-04-60VI48	47 ⁵ / ₈ (1210)	27 ¹ / ₂ (699)	31 ³ / ₄ (806)
	6 (152)	(Pre)-06-60VI48	47 ⁵ / ₈ (1210)	27 ¹ / ₂ (699)	31 ³ / ₄ (806)

(Pre) See page E-10 for catalog number prefix.

All dimensions in shaded areas are millimeters unless otherwise specified.

Vertical Inside Bends 45°, 30° (VI)

1 splice plate with hardware included.

Bend Radius R in. (mm)	Tray Width in. (mm)	45° Vertical Inside Bend Dimensions			
		Catalog No.	A in. (mm)	B in. (mm)	C in. (mm)
12 (305)	3 (76)	(Pre)-03-45VI12	14 ¹ / ₂ (368)	6 (152)	8 ¹ / ₂ (216)
	4 (101)	(Pre)-04-45VI12	14 ⁷ / ₈ (373)	6 ¹ / ₈ (156)	8 ³ / ₄ (222)
	6 (152)	(Pre)-06-45VI12	14 ⁷ / ₈ (373)	6 ¹ / ₈ (156)	8 ³ / ₄ (222)
24 (609)	3 (76)	(Pre)-03-45VI24	23 (584)	9 ¹ / ₂ (241)	13 ¹ / ₂ (343)
	4 (101)	(Pre)-04-45VI24	23 ¹ / ₄ (591)	9 ⁵ / ₈ (245)	13 ⁵ / ₈ (346)
	6 (152)	(Pre)-06-45VI24	23 ¹ / ₄ (591)	9 ⁵ / ₈ (245)	13 ⁵ / ₈ (346)
36 (915)	3 (76)	(Pre)-03-45VI36	31 ³ / ₈ (797)	13 (330)	18 ³ / ₈ (467)
	4 (101)	(Pre)-04-45VI36	31 ³ / ₄ (806)	13 ¹ / ₈ (334)	18 ⁵ / ₈ (473)
	6 (152)	(Pre)-06-45VI36	31 ³ / ₄ (806)	13 ¹ / ₈ (334)	18 ⁵ / ₈ (473)
48 (1218)	3 (76)	(Pre)-03-45VI48	39 ⁷ / ₈ (1013)	16 ¹ / ₂ (419)	23 ³ / ₈ (594)
	4 (101)	(Pre)-04-45VI48	40 ³ / ₈ (1026)	16 ³ / ₄ (425)	23 ⁵ / ₈ (600)
	6 (152)	(Pre)-06-45VI48	40 ³ / ₈ (1026)	16 ³ / ₄ (425)	23 ⁵ / ₈ (600)

30° Vertical Inside Bend					
12 (305)	3 (76)	(Pre)-03-30VI12	12 ¹ / ₈ (308)	3 ¹ / ₈ (83)	6 ¹ / ₂ (165)
	4 (101)	(Pre)-04-30VI12	12 ³ / ₈ (314)	3 ³ / ₈ (86)	6 ⁵ / ₈ (163)
	6 (152)	(Pre)-06-30VI12	12 ³ / ₈ (314)	3 ³ / ₈ (86)	6 ⁵ / ₈ (163)
24 (609)	3 (76)	(Pre)-03-30VI24	18 ¹ / ₈ (461)	4 ³ / ₄ (121)	9 ³ / ₄ (248)
	4 (101)	(Pre)-04-30VI24	18 ³ / ₈ (467)	4 ⁷ / ₈ (124)	9 ⁷ / ₈ (251)
	6 (152)	(Pre)-06-30VI24	18 ³ / ₈ (467)	4 ⁷ / ₈ (124)	9 ⁷ / ₈ (251)
36 (915)	3 (76)	(Pre)-03-30VI36	24 ¹ / ₄ (616)	6 ¹ / ₂ (165)	13 (330)
	4 (101)	(Pre)-04-30VI36	24 ¹ / ₂ (622)	6 ⁵ / ₈ (168)	13 ¹ / ₈ (334)
	6 (152)	(Pre)-06-30VI36	24 ¹ / ₂ (622)	6 ⁵ / ₈ (168)	13 ¹ / ₈ (334)
48 (1218)	3 (76)	(Pre)-03-30VI48	30 ³ / ₈ (772)	8 ¹ / ₈ (207)	16 ¹ / ₄ (413)
	4 (101)	(Pre)-04-30VI48	30 ⁵ / ₈ (778)	8 ¹ / ₄ (210)	16 ³ / ₈ (416)
	6 (152)	(Pre)-06-30VI48	30 ⁵ / ₈ (778)	8 ¹ / ₄ (210)	16 ³ / ₈ (416)

(Pre) See page E-10 for catalog number prefix.

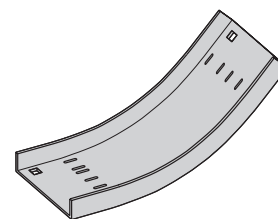

45° Vertical Inside Bend
Ventilated Vertical Inside Bend

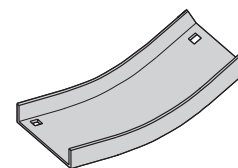
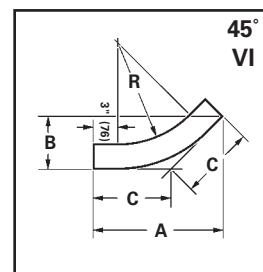

30° Vertical Inside Bend
Non-Ventilated Vertical Inside Bend

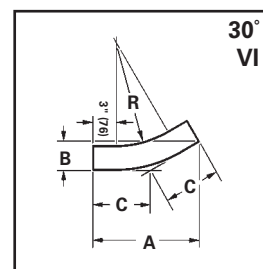

All dimensions in shaded areas are millimeters unless otherwise specified.

Section 1- Acceptable Manufacturers

- 1.01 Manufacturer: Subject to compliance with these specifications, B-Line series channel cable tray systems shall be as manufactured by Eaton.

Section 2- Selection and Components

- 2.01 General: Except as otherwise indicated, provide ventilated metal channel cable trays, of types, classes and sizes indicated with splice connectors, fittings and all other necessary accessories for a complete system. Provide channel cable tray with rounded edges and smooth surfaces in compliance with applicable standards, and with the following additional requirements.
- 2.02 Materials and finishes: Material and finishes specifications for each channel cable tray are as follows:
1. Aluminum: Extruded components shall be made from Aluminum Association Alloy 6063. All fabricated parts shall be made from Aluminum Association Alloy 5052.
 2. Pre-Galvanized Steel: Straight sections and fittings shall be made from structural quality mill galvanized 14 gauge steel meeting the properties of ASTM A653SS, coating designation G90.
 3. Hot Dip Galvanized Steel: Straight sections and fittings shall be made from 14 gauge structural quality steel meeting the minimum mechanical properties of ASTM A1011 SS, Grade 33 and shall be hot-dip galvanized after fabrication in accordance with ASTM A123.
All hot dip galvanized after fabrication cable trays must be returned to point of manufacture after coating for inspection, conditioning and labeling.
 4. Stainless Steel: Straight sections and fittings shall be AISI Type [304] [316].
- 2.03 Channel cable tray straight sections shall be constructed with ventilated flat bottom. Ventilating bottom shall be perforated with 2.25" diameter holes and have slots to facilitate the use of cable ties to secure the cables.
- 2.04 Straight sections shall be supplied in standard [12 foot] [10 foot (3 m)] lengths, except where shorter lengths are permitted to facilitate tray assembly as shown on drawings.
- 2.05 Ventilating straight sections shall have splice holes every 12 inches to simplify field modifications.
- 2.06 Channel cable tray width shall be [3] [4] [6] inches with a minimum loading depth of 1 1/4".
- 2.07 Fittings will have a minimum radius of [12] [24] [36] [48] inches.
- 2.08 Splice plates and hardware shall be included with each straight section and fitting.



KwikRail cable tray system advantages

The KwikRail straight sections are available with welded rungs or bolted rungs to allow installers to add or remove rungs* in the field.

The straight sections and fittings feature perforations along the side rail to allow you to quickly and easily alter the system.

Plus, add-rung-kits allow you to add rung at any location along the length of the tray making cable support and adding accessories simple to achieve.

- I-beam rungs provide high strength to weight ratio
- Vibration tested
- Patented fastener holes provide maximum grip for fastener threads
- Innovative time saving accessories
- Fast, easy to modify tray in the field

Patent Information

U.S. Patent D361982; 5,580,014

Canada 2,137,879

UK Patent 2,285,343

**If your application requires removal of more than one (1) rung from a KwikRail straight section, please contact the B-Line series technical team. We do not recommend removing rungs from the welded system. Please contact us if you have any questions.*

Straight Sections

see pages KR-1 – KR-3

Accessories

see pages KR-4 – KR-15

Covers

see page KR-10

Fittings

see pages KR-16 – KR-20

Specifications

see pages KR-21 – KR-22

KwikRail Aluminum Cable Tray - Straight Sections

KwikRail Straight Section Part Numbering

Prefix

Example: **KR A 4 A B 09 - 12 - 144**

Series	NEMA Class	Height	Material	Fabrication	Type	Width	Length
KR	A = 50 Lbs/Ft NEMA 12A (12 ft. span) B = 75 Lbs/Ft NEMA 12B (12 ft. span)	4 = 4" 6 = 6"***	A = Aluminum	Blank = Welded B = Bolted	<ul style="list-style-type: none"> ● SB = Solid Bottom* ● 04 = 4" rung spacing* ● 06 = 6" rung spacing ● 09 = 9" rung spacing ● 12 = 12" rung spacing 	<ul style="list-style-type: none"> 06 = 6" 09 = 9" 12 = 12" 18 = 18" 24 = 24" 30 = 30" 36 = 36" 	<ul style="list-style-type: none"> ● 144 = 12 ft. ● 120 = 10 ft.

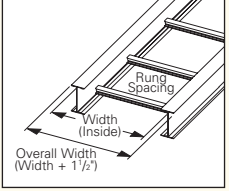

* 4" rung spacing and solid bottom only available on welded fabrication.
** Only available in NEMA 12 B class

● Green = Fastest shipped items ● Black = Normal lead-time items

KwikRail Cable Tray

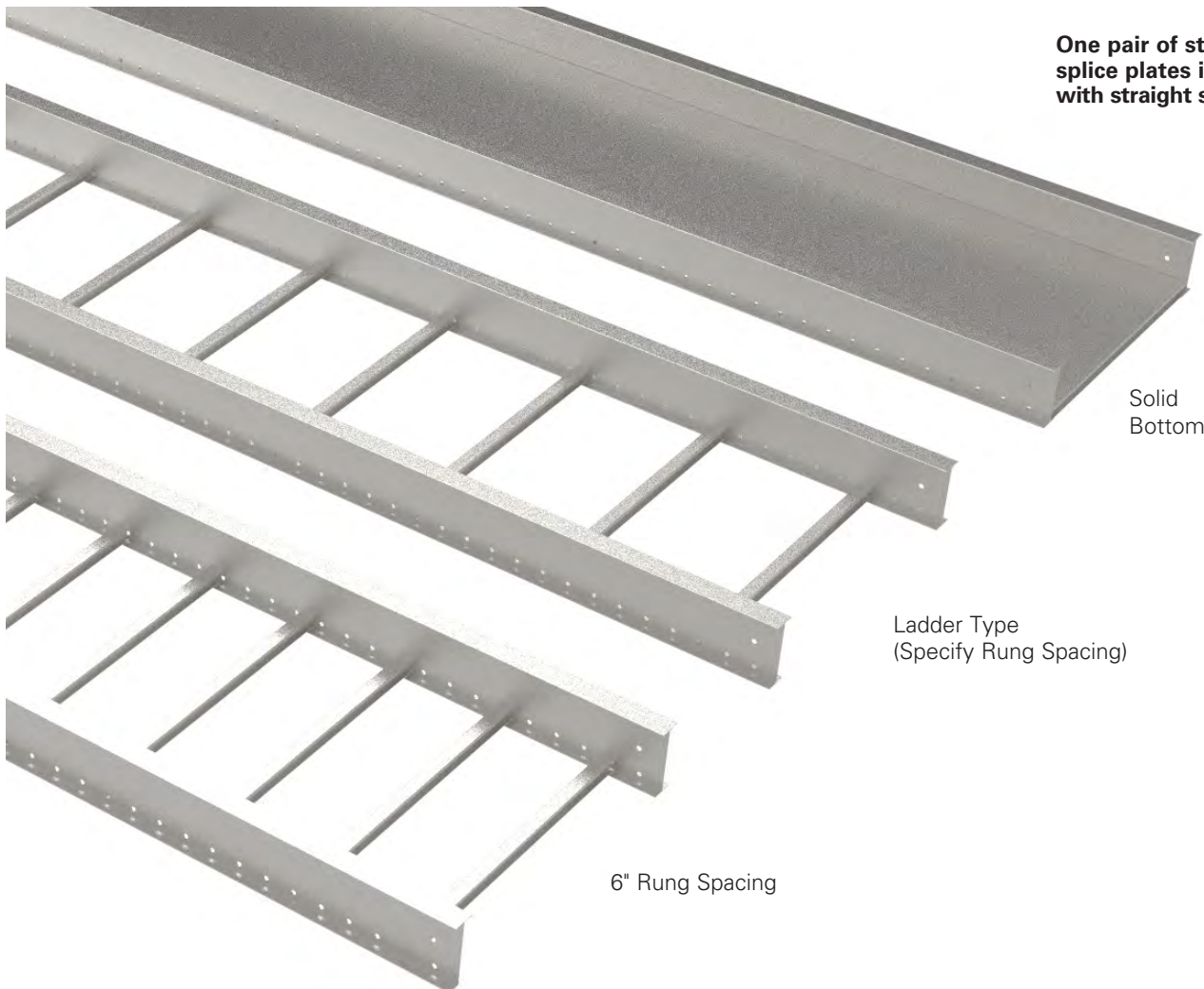

One pair of standard splice plates included with straight sections.

Solid Bottom

Ladder Type
(Specify Rung Spacing)

6" Rung Spacing

All dimensions in parentheses are millimeters unless otherwise specified.

KRA4A, KRB4A and KRB6A Straight Section Technical Data

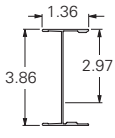
Side Rail Dimensions	NEMA, CSA & UL Classifications	Span ft	Load lbs/ft	Deflection Multiplier	Design Factors for Two Rails	Span meters	Load kg/m	Deflection Multiplier	Design Factors for Two Rails
KRA4A 	NEMA: 12A CSA: C-3m UL Cross-Sectional Area: 0.60 in ²	6	221	0.0016	Area = 0.80 in ² Sx = 0.90 in ³ Ix = 1.79 in ⁴	1.8	328	0.028	Area = 5.16 cm ² Sx = 14.75 cm ³ Ix = 74.51 cm ⁴
		8	124	0.0051		2.4	185	0.088	
		10	79	0.0126		3.0	125	0.215	
		12	55	0.0261		3.7	82	0.445	

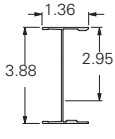
Side Rail Dimensions	NEMA, CSA & UL Classifications	Span ft	Load lbs/ft	Deflection Multiplier	Design Factors for Two Rails	Span meters	Load kg/m	Deflection Multiplier	Design Factors for Two Rails
KRB4A 	NEMA: 12B CSA: D-3m UL Cross-Sectional Area: 0.60 in ²	8	198	0.0040	Area = 0.99 in ² Sx = 1.07 in ³ Ix = 2.32 in ⁴	2.4	295	0.068	Area = 6.39 cm ² Sx = 17.53 cm ³ Ix = 96.57 cm ⁴
		10	127	0.0097		3.0	195	0.166	
		12	88	0.0201		3.7	131	0.343	

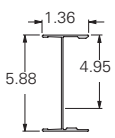
Side Rail Dimensions	NEMA, CSA & UL Classifications	Span ft	Load lbs/ft	Deflection Multiplier	Design Factors for Two Rails	Span meters	Load kg/m	Deflection Multiplier	Design Factors for Two Rails
KRB6A 	NEMA: 12B CSA: D-3m UL Cross-Sectional Area: 1.00 in ²	8	170	0.0015	Area = 1.25 in ² Sx = 1.91 in ³ Ix = 6.16 in ⁴	2.4	266	0.026	Area = 8.06 cm ² Sx = 31.30 cm ³ Ix = 256.40 cm ⁴
		10	114	0.0037		3.0	179	0.062	
		12	79	0.0076		3.7	118	0.129	

When cable trays are used in continuous spans, the deflection of the cable tray is reduced by as much as 50%.
 Design factors: Ix = Moment of Inertia, Sx = Section Modulus.

Values are based on simple beam tests per NEMA VE-1 on 36" wide cable tray with rungs spaced on 12" centers. The published load safety factor is 1.5. To convert 1.5 safety factor to 2.0, multiply the published load by 0.75. To obtain mid-span deflection, multiply a load by the deflection multiplier. Cable tray must be supported on spans shorter than or equal to the length of the tray.

KwikRail Cable Tray

KwikRail Aluminum Cable Tray - Accessories

Standard Splice Plates

- Furnished in pairs with 1/4" hardware.
- UL Classified as equipment grounding conductor.
- Splice plates and hardware included with straight sections and fittings.

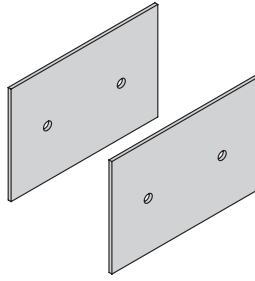

Tray Series	Catalog No.
KR_4A	KR4A-SSP
KRB6A	KR6A-SSP

- = insert A or B for class

Expansion Splice Plates

- Furnished in pairs with 1/4" hardware.
- Bonding jumpers required on each side rail.

Requires supports within 24" on both sides, per NEMA VE 2.

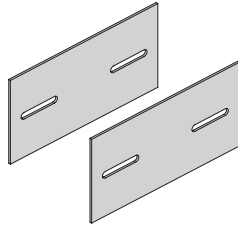

Tray Series	Catalog No.
KR_4A	KR4A-ESP
KRB6A	KR6A-ESP

- = insert A or B for class

Step Down Splice Plates

- Furnished in pairs with 1/4" hardware.
- UL Classified as equipment grounding conductor.

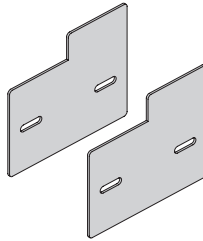

Tray Series	Catalog No.
KR_4A to KRB6A	KRA-DSP-46

- = insert A or B for class

Vertical Adjustable Splice Plates

- Furnished in pairs with 1/4" hardware.
- UL Classified as equipment grounding conductor.
- Bonding jumpers not required.
- Requires supports within 24" on both sides, per NEMA VE 2.

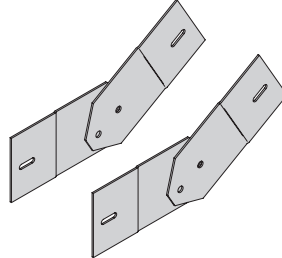

Tray Series	Catalog No.
KR_4A	KR4A-VSP
KRB6A	KR6A-VSP

- = insert A or B for class

Horizontal Adjustable Splice Plates (Flex-Mount™)

- Furnished in pairs with 1/4" hardware.
- Horizontally adjustable to 90°.
- Vertically adjustable to 15°.
- UL Classified as equipment grounding conductor.
- Requires supports within 24" on both sides, per NEMA VE 2.
- For optional rung, see page KR-14.

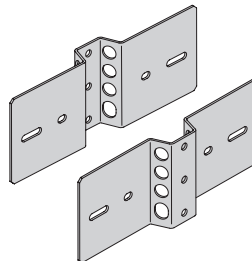

Tray Series	Catalog No.
KR_4A	KR4A-FSP
KRB6A	KR6A-FSP

- = insert A or B for class

Tray-To-Box Splice Plates

- Furnished in pairs with 1/4" hardware.
- UL Classified as equipment grounding conductor.

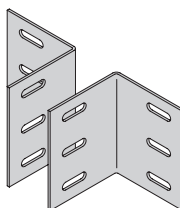

Tray Series	Catalog No.
KR_4A	KR4A-TTB
KRB6A	KR6A-TTB

- = insert A or B for class

All dimensions in parentheses are millimeters unless otherwise specified.

KwikRail Aluminum Cable Tray - Accessories

Offset Reducing Splice Plates

- Furnished in pairs with 1/4" hardware.
- UL Classified as equipment grounding conductor.

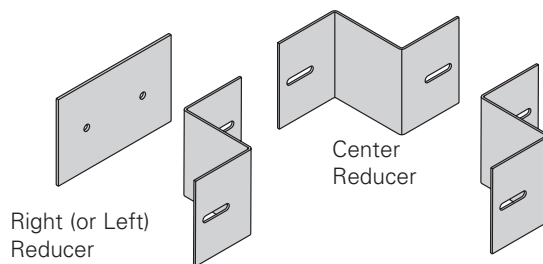

Tray Series	Catalog No.
KR_4A	KR4A-RSP-† r
KRB6A	KR6A-RSP-† r

- = insert A or B for class
Specify the following:
† C = center reducer
S = side reducer
r (tray reduction) 3", 6", 9", 12", 15", 18", 21", 24", 27", or 30"

Adapter Splice Plates

- Furnished in pairs with 1/4" hardware.
- For transitioning from Redi-Rail to KwikRail.

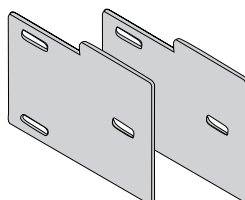

Tray Series	Catalog No.
KR_4A	KR4A-ASP
KRB6A	KR6A-ASP

- = insert A or B for class

Frame Type Box Connector

- Furnished with 1/4" hardware for tray connection.
- UL Classified as equipment grounding conductor.

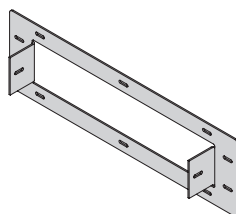

Tray Series	Catalog No.
KR_4A	KR4A-FTB-†
KRB6A	KR6A-FTB-†

† = Insert tray width

Bonding Jumper

- Sold individually with 1/4" hardware.
- UL Classified as equipment grounding conductor.
- Length: 14 1/2" (368mm)

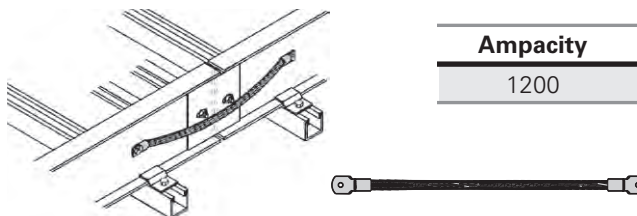

Ampacity	Catalog No.
1200	99-30

Grounding Clamp

- Accepts #6 AWG to 250 MCM.
- UL Classified, suitable as equipment grounding conductor.

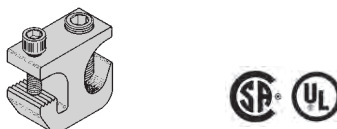

Material	Catalog No.
Tin plated aluminum	9A-2130

Conduit-to-Tray Adaptors

- For easy attachment of conduit terminating at a cable tray.
- Use on aluminum or steel cable trays.

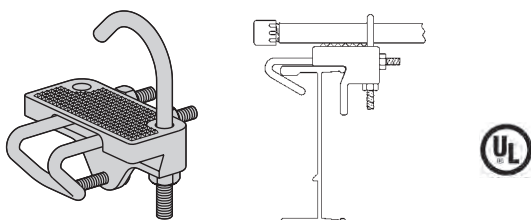

Conduit Size in. (mm)	Catalog No.
1/2, 3/4 (15, 20)	9G-1158-1/2 & 3/4
1, 1 1/4 (25, 32)	9G-1158-1 & 1 1/4
1 1/2, 2 (40, 50)	9G-1158-1 1/2 & 2
2 1/2, 3 (65, 80)	9G-1158-2 1/2 & 3
3 1/2, 4 (90, 100)	9G-1158-3 1/2 & 4

Guide-Rite™ Conduit-to-Tray Adaptor

- Assemblies support 1/2", 3/4", & 1" conduit.
- Attaches to top or bottom of I-Beam side rail flange.

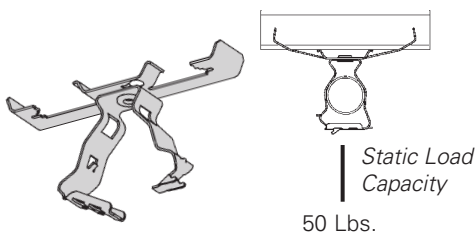

Conduit Size in. (mm)	Catalog No.
1/2, 3/4 (15, 20)	BG-8-12-W2
1, 1 1/4 (25, 32)	BG-16-W2

Patent #4958792

All dimensions in parentheses are millimeters unless otherwise specified.

KwikRail Aluminum Cable Tray - Accessories

Drop-Out

- Snaps on to both bolted and welded rung variations .
- Provides 4" (101mm) radius.
- Holes provided to secure cables.

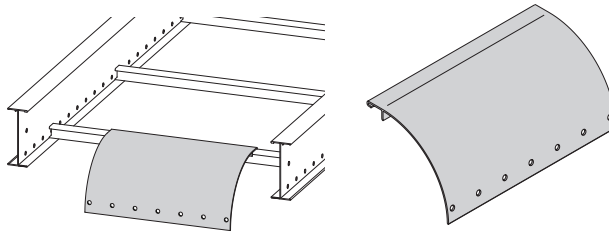

Catalog No.

KRA-OUT-†

† = Insert tray width

Side Rail Drop-Out

- Snaps on to cable tray side rail.
- Provides 4" (101mm) radius.
- Holes provided to secure cables.

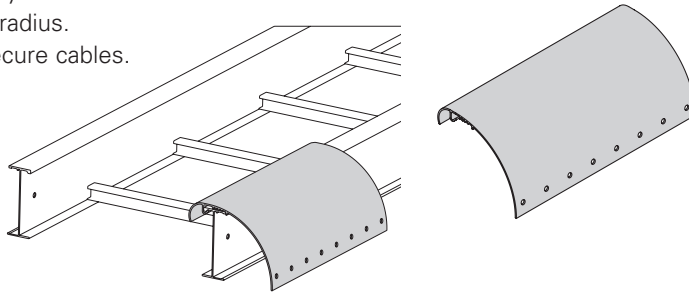

Catalog No.

Length

in. (mm)

KRA-SDO-06 6 (152)

KRA-SDO-12 12 (305)

KRA-SDO-18 18 (457)

Clamp/Guide

- Features a no-twist design.
- Each side is labeled to ensure proper installation.
- Designed for 1/4" hardware.
- Furnished in pairs with or without hardware.

Patent No.
RE35479

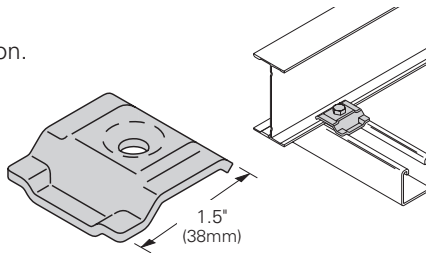

Catalog No.

9ZN-1204 (without hardware)

9ZN-1204NB (with hardware)

Blind End

- Furnished as one plate with 1/4" hardware.

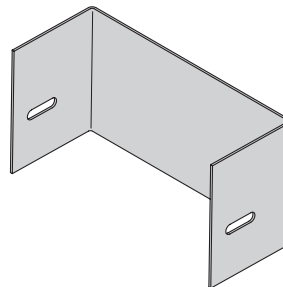

Tray
Series

Catalog No.

KR_4A **KR4A-END-†**

KRB6A **KR6A-END-†**

† = Insert tray width

_ = insert A or B for class

Hanger Rod Bracket

- Furnished as pair of studded clamps with 1/4" serrated flanged lock nuts.
- Loading is 1,000 lbs. (4.45kN) per pair with safety factor of 3.
- Position ATR 3" (76mm) wider than cable tray.

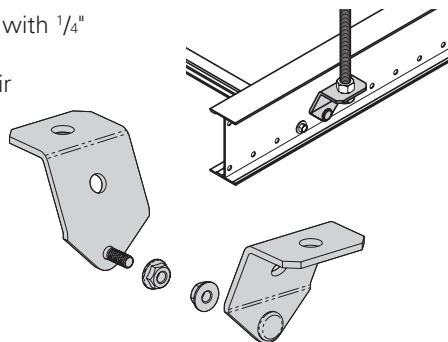

Support
ATR Size

Catalog No.

3/8" **9(*)-R238**

1/2" **9(*)-R250**

(*) Insert ZN option or SS4 option

All dimensions in parentheses are millimeters unless otherwise specified.

Tab and Lock Trapeze Support

- Hardware purchased separately.
- Accepts up to 3/8" rod.
- Accepts traditional hold down clamps (9ZN-1204) if necessary.
- Ability to adjust tabs with flat head screw driver (not included).
- Tabs clamp cable tray to trapeze support.
- Load capacity: Rated for maximum load of KwikRail cable tray system.
- Corrosion resistant pre-galvanized zinc finish.
- Other finishes available upon request.

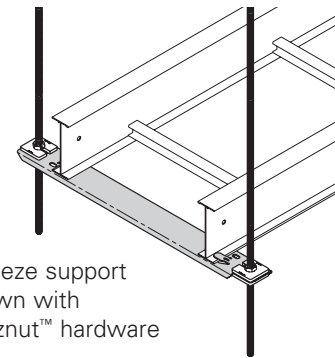

Trapeze support shown with Buzznut™ hardware

Trapeze support only

Hardware	Qty.	Catalog No.
Standard	(4)	B201
	(4)	3/8" HN
or		
Buzznut	(4)	SLWN3/8

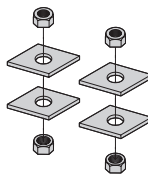

Standard hardware

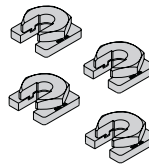

Buzznut hardware

Catalog No.	Tray Width	
	in.	(mm)
KRA-06CT	6	(152)
KRA-09CT	9	(229)
KRA-12CT	12	(305)
KRA-18CT	18	(457)
KRA-24CT	24	(610)
KRA-30CT	30	(762)
KRA-36CT	36	(914)

Trapeze Support Kit

Kit includes components for a single trapeze in one package.

- Kits available in pre-galvanized (P) or hot dip galvanized steel (G) with 316 stainless steel hardware.
- SH channel has pre-punched slots to eliminate field drilling
- Hardware is shipped in sealed plast back and boxed with pre-cut strut.
- Design for use with 1/2" all threaded rod (sold separately).
- Safety factor of 3.0 on all loads.

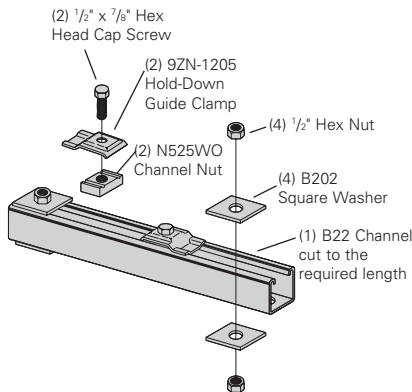
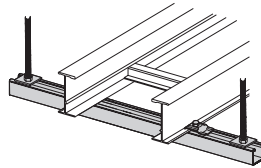

Catalog No.	Tray Width		Channel Length	Uniform Load	
	in.	(mm)		lbs	(kN)
9(*)-5506-22SH(†)	6	(152)	16	(406)	1600 (7.11)
9(*)-5509-22SH(†)	9	(229)	18	(457)	1250 (5.56)
9(*)-5512-22SH(†)	12	(305)	22	(559)	1125 (5.00)
9(*)-5518-22SH(†)	18	(457)	28	(711)	865 (3.85)
9(*)-5524-22SH(†)	24	(610)	34	(864)	700 (3.11)
9(*)-5530-22SH(†)	30	(762)	40	(1016)	590 (2.62)
9(*)-5536-22SH(†)	36	(914)	46	(1168)	510 (2.27)

- (*) Insert **P** or **G**
- (†) Insert 3/8" for 3/8" threaded rod hardware.

Trapeze Hardware Kit

- Hardware shipped in plastic bag.

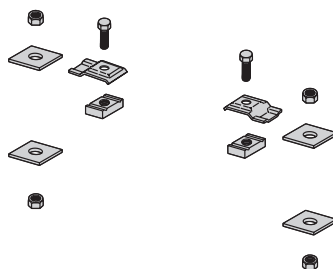

Catalog No.	
9ZN-5500-1/2	9G-5500-1/2
(1) pr. 9ZN-1205	(1) pr. 9G-1205
(2) HHC Screw 1/2 x 7/8 ZN	(2) HHC Screw 1/2 x 7/8 SS6
(2) N525 WO ZN	(2) N525 WO SS6
(4) B202 ZN 1/2" sq washer	(4) B202 HDG 1/2" sq washer
(4) HN 1/2 ZN	(4) HN 1/2 SS6

All dimensions in parentheses are millimeters unless otherwise specified.

KwikRail Aluminum Cable Tray - Accessories

Bracket

- Finishes available: ZN, GRN, or HDG.
- Safety Load Factor 2.5.
- Bottom brace is B42 channel on B494-24 and smaller and B22 channel on B494-30 and larger.

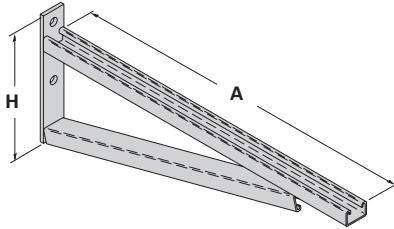

Catalog No.	Uniform Load		Tray Width		'A'		'H'	
	lbs	(kN)	in.	(mm)	in.	(mm)	in.	(mm)
B494-12	2500	(11.12)	6 & 9	(152 & 229)	12	(305)	8 ³ / ₄	(222)
B494-18	1700	(7.56)	12	(305)	18	(457)	8 ³ / ₄	(222)
B494-24	1300	(5.78)	18	(457)	24	(610)	8 ³ / ₄	(222)
B494-30	1600	(7.11)	24	(610)	30	(762)	11 ¹ / ₄	(286)
B494-36	1100	(4.89)	30	(762)	36	(914)	11 ¹ / ₄	(286)
B494-42	980	(4.36)	36	(914)	42	(1067)	16	(406)

For more dimensional data, see B-Line series Strut Systems catalog.

Cantilever Bracket

- Finishes available: ZN, GRN, HDG, SS4 or SS6.
- Safety Load Factor 2.5.

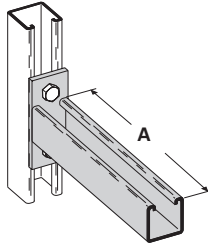

Catalog No.	Uniform Load		Tray Width		'A'	
	lbs	(kN)	in.	(mm)	in.	(mm)
B409-12	960	(4.27)	6 & 9	(152 & 229)	12	(305)
B409-18	640	(2.84)	12	(305)	18	(457)
B409-24	480	(2.13)	18	(457)	24	(610)

For more dimensional data, see B-Line series Strut Systems catalog.

Cantilever Bracket

- Finishes available: ZN, GRN, HDG, or SS4.
- Safety Load Factor 2.5.

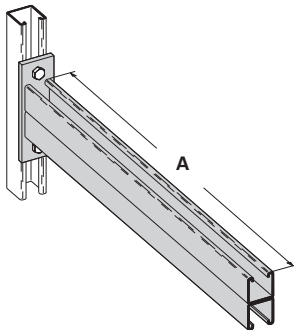

Catalog No.	Uniform Load		Tray Width		'A'	
	lbs	(kN)	in.	(mm)	in.	(mm)
B297-12	1660	(7.38)	6 & 9	(152 & 229)	12	(305)
B297-18	1100	(4.89)	12	(305)	18	(457)
B297-24	835	(3.71)	18	(457)	24	(610)
B297-30	665	(2.95)	24	(610)	30	(762)
B297-36	550	(2.44)	30	(762)	36	(914)
B297-42	465	(2.06)	36	(914)	42	(1067)

For more dimensional data, see B-Line series Strut Systems catalog.

All dimensions in parentheses are millimeters unless otherwise specified.

KwikRail Aluminum Cable Tray - Accessories

Underfloor Support (U-Bolts not included)

- Finishes available: ZN.
- Safety Load Factor 2.5.
- Order 2 properly sized U-Bolts (sold separately) for each underfloor support.

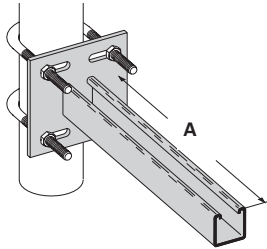

Catalog No.	Uniform Load		Tray Width		'A'	
	lbs	(kN)	in.	(mm)	in.	(mm)
B409UF-12	800	(3.55)	6 & 9	(152 & 229)	12	(305)
B409UF-21	450	(2.00)	12 & 18	(305 & 457)	21	(533)

U-Bolt Size	Fits Pipe O.D.	
	in.	(mm)
B501-3/4	.841 - 1.050	(21 - 26)
B501-1	1.051 - 1.315	(27 - 33)
B501-1 1/4	1.316 - 1.660	(33 - 42)
B501-1 1/2	1.661 - 1.900	(42 - 48)
B501-2	1.901 - 2.375	(48 - 60)
B501-2 1/2	2.376 - 2.875	(60 - 73)

Heavy Duty Hold Down Bracket

- Design load is 2000 lbs/pair.
- Two bolt design.
- Sold in pairs.
- 3/8" cable tray attachment hardware provided.
- 3/8" support attachment hardware **not** provided.
- (*) Insert ZN, SS4, or SS6.

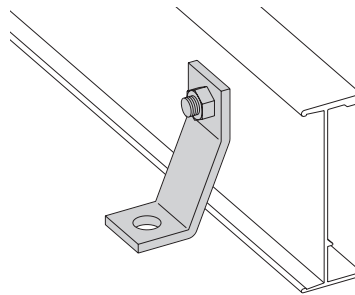

Catalog No.

9(*)-1241

Under Rung Fastener Attachment

- Supports electrical fixtures from bottom of rung or siderails.
- Wing nut included.
- Various 1/4"-20 stud lengths available.
- Static Load Capacity: 75 Lbs. (34kg).

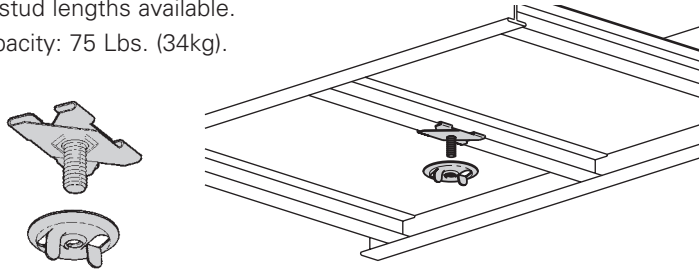

Catalog No.	Stud Length
	in. (mm)
BAX-4-16	5/8 (16)
BAX-4-16-24	1 1/2 (38)
BAX-4-16-32	2 (51)
BAX-4-16-48	3 (76)

DURA-BLOK™ Support Bases with B22 Channel

- Designed as a superior rooftop support for cable tray, UV resistant and approved for most roofing material or other flat surfaces.
- Can be used with any of our cable tray clamps and guides.
- Ultimate Uniform Load Capacity: 1,000 lbs. (4.45kN).



Catalog No.	Height x Width x Length	
	in.	(mm)
DB10-28	5 5/8 x 6 x 28	(143 x 152 x 711)
DB10-36	5 5/8 x 6 x 36	(143 x 152 x 914)
DB10-42	5 5/8 x 6 x 42	(143 x 152 x 1067)
DB10-50	5 5/8 x 6 x 50	(143 x 152 x 1270)
DB10-60	5 5/8 x 6 x 60	(143 x 152 x 1524)

General Note: Consult roofing manufacturer or engineer for roof load capacity. The weakest point may be the insulation board beneath the rubber membrane.



LEEDS credit available, base made from 100% recycled material.

All dimensions in parentheses are millimeters unless otherwise specified.

Covers for KRA4A, KRB4A and KRB6A

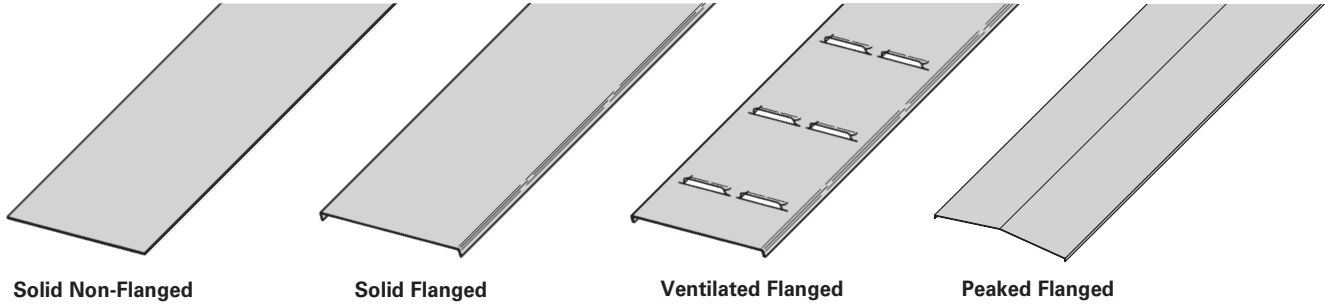

A full range of covers are available for straight sections and fittings.

Solid covers should be used when maximum enclosure of the cable is desired and no accumulation of heat is expected.

Ventilated covers provide cable protection, while allowing heat to escape.

Flanged covers have a 1/2 in. (13 mm) flange. Cover clamps are not included with the cover and must be ordered separately.

We recommend that covers be placed on vertical cable tray runs to a height of 6 ft. (1.83 m) to 8 ft. (2.44 m) above the floor to isolate both cables and protect personnel.

KwikRail Cable Tray

Aluminum Cover Part Numbering

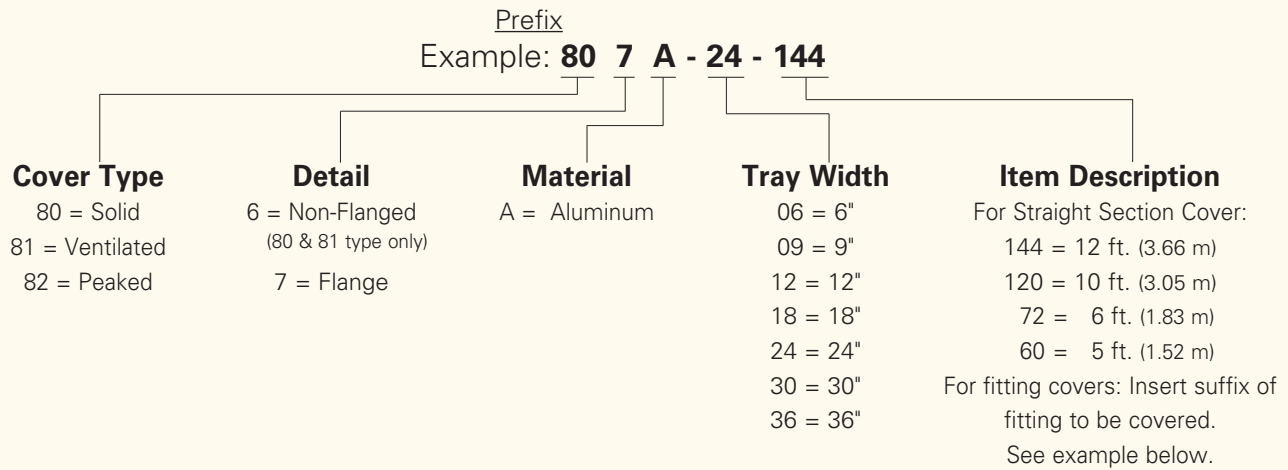

Examples of Catalog Numbers for Fitting Covers:

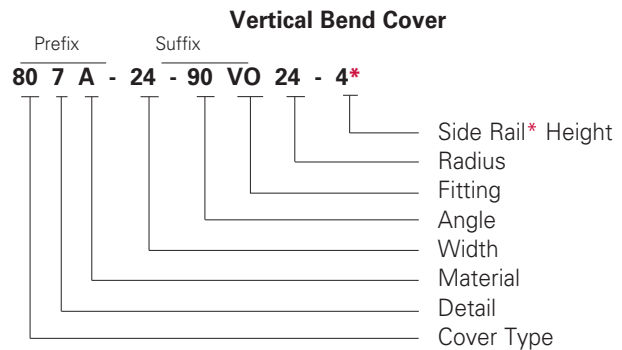
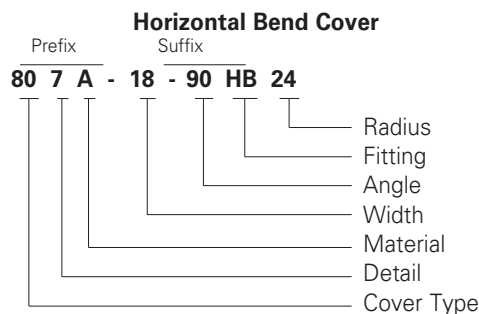

* Required for VO fittings only

All dimensions in parentheses are millimeters unless otherwise specified.

KwikRail Aluminum Cable Tray - Accessories

Standard Cover Clamp

- For indoor service only.
- Setscrew included.
- Sold per piece.



Tray Type	Side Rail Height	Catalog No.
KR Series	All Sizes	9ZN-9012
		9A-9012

Heavy Duty Cover Clamp

- Recommended for outdoor service.

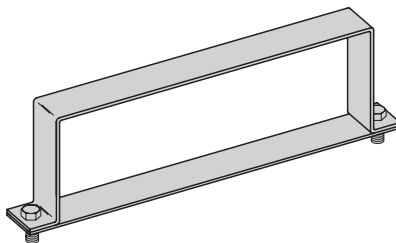

Side Rail Height in. (mm)	Catalog No.
4 (101)	KR4A-HDCC-(±)
6 (152)	KR6A-HDCC-(±)

(±) Insert tray width

Quantity of Standard Cover Clamps Required

Straight Section 60" or 72"	4 pcs.
Straight Section 120" or 144"	6 pcs.
Horizontal/Vertical Bends	4 pcs.
Tees	6 pcs.
Crosses	8 pcs.

Notes:

When using the Heavy Duty Cover Clamp, only one-half the number of clamps stated above is required.

Additional clamps may be necessary in extreme wind applications.

Cover Joint Strip

- Used to join covers.
- Plastic.
- (±) Insert tray width.

Catalog No.

99-9980-(±)

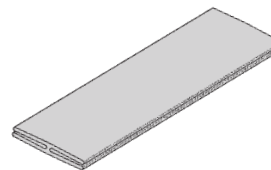

All dimensions in parentheses are millimeters unless otherwise specified.

KwikRail Aluminum Cable Tray - Accessories

Out Board Rungs

- Formed aluminum rung with attachment screw.
- Field installs as required.
- Torque rung fasteners to 6 ft•lbs.
- Uniform load capacity on rung: 10 lbs. (0.04kN)

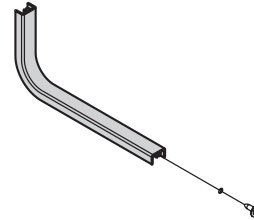
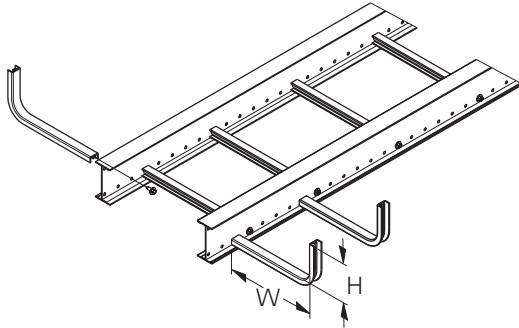

Catalog No.	Fill Depth 'H' in (mm)	Width 'W' in (mm)
9A-SR0406	4 101	6 152
9A-SR0409	4 101	9 226
9A-SR0506	5 127	6 152
9A-SR0509	5 127	9 226

Add-A-Rung™ Kit

- Kit allows an additional rung to be added to a desired location throughout the tray system.
- Pre-cut rung sections supplied.
- Attachment hardware is included.
- Torque rung fasteners to 18 ft•lbs.
- Add-A-Rung kit can be added to welded or bolted versions of KwikRail.
- Add-A-Rung kit does not work on any of the KwikRail horizontal fittings.
- Add-A-Rung does work with KwikRail VI/VO fittings.

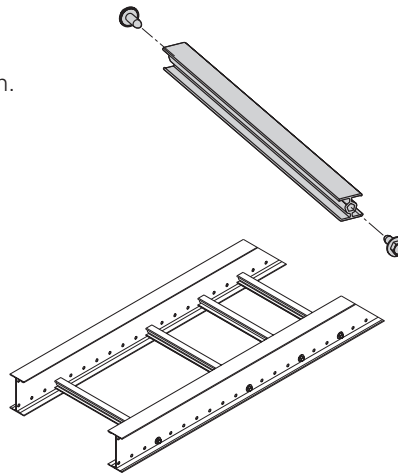

Tray Width in (mm)	Catalog No.
6 (152)	9A-R06RK
9 (226)	9A-R09RK
12 (305)	9A-R12RK
18 (452)	9A-R18RK
24 (609)	9A-R24RK
30 (762)	9A-R30RK
36 (914)	9A-R36RK

Barrier Strip Clip

- Provides attachment to bolted or welded KwikRail rungs.
- Allows for installed barrier adjustment.
- Asymmetrical clip provides a wide range for screw location.
- Barrier strip clips and hardware are included with all barriers.

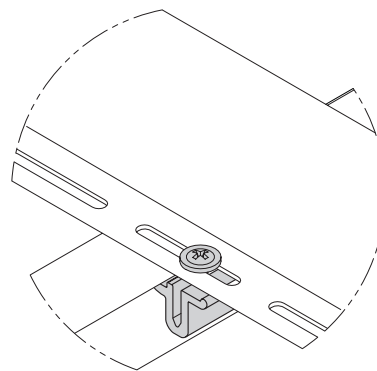

Catalog No.
9A-RBC

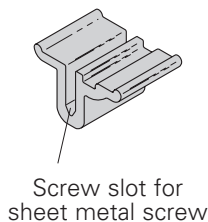

Barrier Flange

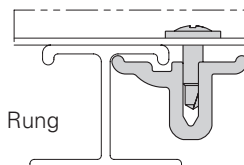

Welded rung assembly

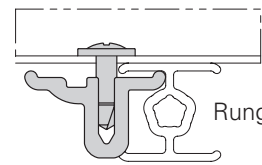

Bolted rung assembly

All dimensions in parentheses are millimeters unless otherwise specified.

Straight Section Barrier Strip

- Furnished with four (4) barrier strip clips, mounting hardware and splice.
- Standard lengths are 144" or 12 ft (3.7m) & 120" or 10 ft (3.0m).
- Order catalog number based on loading depth 'H'.

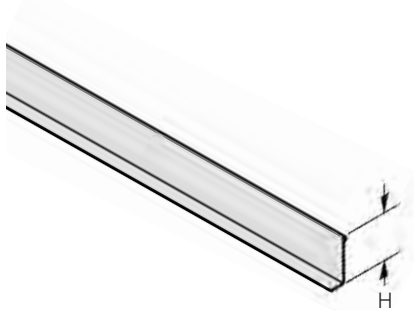

Tray Series	Catalog No.	H	
		in.	(mm)
KR_4A	KR4A-DSL-Length	3	(76)
KRB6A	KR6A-DSL-Length	5	(127)

Horizontal Bend Barrier Strip

- Furnished with three (3) barrier strip clips, mounting hardware and splice.
- Standard length is 72" or 6 ft (1.8m).
- Flexible to fit desired angles.
- Order catalog number based on loading depth 'H'.

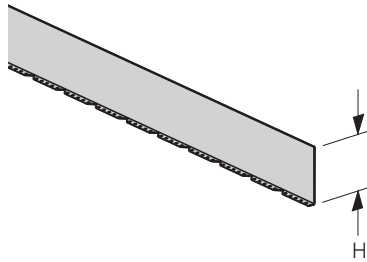

Tray Series	Catalog No.	H	
		in.	(mm)
KR_4A	KR4A-DHB	3	(76)
KRB6A	KR6A-DHB	5	(127)

Vertical Bend Barrier Strip

- Furnished with three (3) barrier strip clips, mounting hardware and splice.

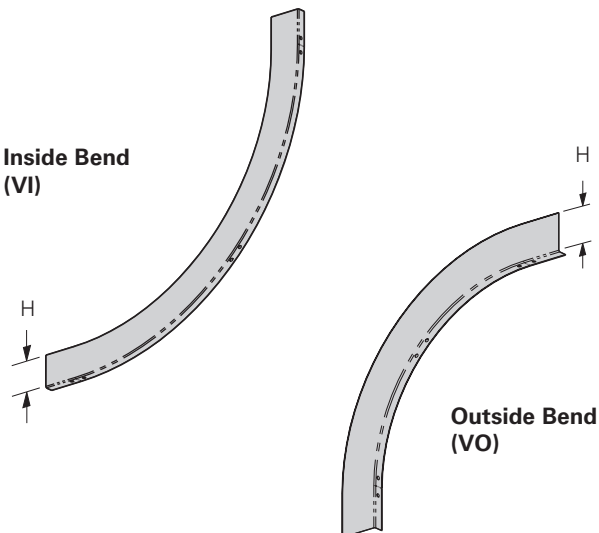

Tray Series	Catalog No.		H
	Inside Bend	Outside Bend	
KR_4A	KR4A-DVI-(**R)(†)	KR4A-DVO-(**R)(†)	3 (76)
KRB6A	KR6A-DVI-(**R)(†)	KR6A-DVO-(**R)(†)	5 (127)

(**) Insert 45°, 90° for angles
 (†) Insert 12, 24 for radius

All dimensions in parentheses are millimeters unless otherwise specified.

KwikRail Aluminum Cable Tray - Accessories

How to miter cut KwikRail cable tray for use with Horizontal Adjustable splice plates.

- Mark desired hole/cut locations per chart.
- Remove any rungs (if necessary) affected by cuts.
- Cut side rails through center of required holes per chart.
- Mount outside Horizontal Adjustable splice plate with provided hardware and bend KwikRail sections to desired angle.
- Form inside Horizontal Adjustable splice plate to fit contour of inner rails and bolt into place.
- Reinstall (if necessary) appropriate rungs. Torque to 18 ft•lbs.
- If Splice Rung Kit (see below) is required, order separately.
- Recommend adding one to the value in the chart if the first hole is less than $\frac{3}{8}$ " (9.5mm) from the end of tray.

Tray Width in. (mm)	Cut Length from Rail End For Desired Angle			
	30° in. (mm)	45° in. (mm)	60° in. (mm)	90° in. (mm)
6 (152)	1 ⁵ / ₈ (41.3)	3 ¹ / ₈ (79.4)	3 ¹ / ₈ (79.4)	6 ¹ / ₄ (158.7)
9 (228)	3 ¹ / ₈ (79.4)	3 ¹ / ₈ (79.4)	4 ³ / ₄ (120.6)	9 ³ / ₈ (238.2)
12 (305)	3 ¹ / ₈ (79.4)	4 ¹ / ₈ (120.6)	6 ¹ / ₄ (158.7)	12 ⁵ / ₈ (320.7)
18 (457)	4 ³ / ₄ (120.6)	7 ⁷ / ₈ (200.0)	11 (279.4)	17 ¹ / ₄ (438.1)
24 (609)	6 ¹ / ₄ (158.7)	9 ³ / ₈ (238.2)	14 ¹ / ₈ (358.8)	23 ⁵ / ₈ (600.1)
30 (762)	7 ⁷ / ₈ (200.0)	12 ⁵ / ₈ (320.7)	17 ¹ / ₄ (438.1)	29 ⁷ / ₈ (758.8)
36 (914)	9 ³ / ₈ (238.2)	15 ³ / ₄ (400.0)	20 ³ / ₈ (517.5)	36 ¹ / ₈ (917.6)

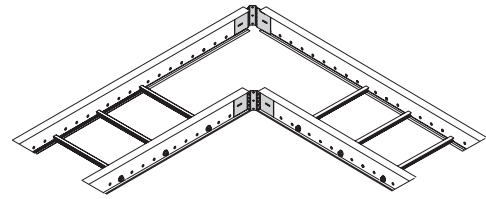
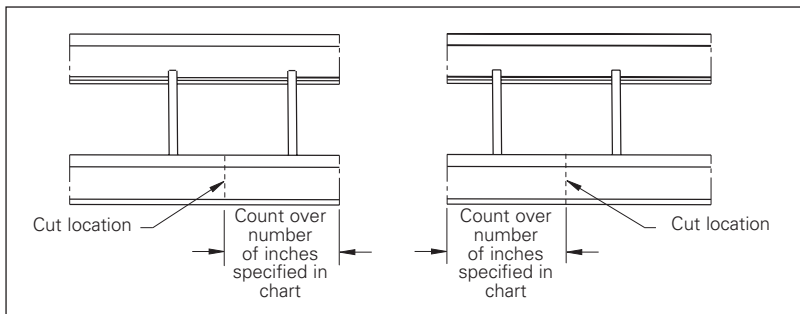

KRA5A09-12-144 Straight Section shown with required side rail removed to form 90° fitting.

Example: For a 12" (305mm) wide 90° bend, the cuts must be made 12⁵/₈" (320.7mm) from the end.

Flex-Mount Splice Rung Kit

- Kit allows a support rung to be added to flex-mount splice plates so that cables may be supported through a bend.
- The support rung is available in three lengths and should be ordered based upon tray width.
- The rung length is sized so that it will fit a maximum tray width when Flex-Mount™ splices are used to make a bend up to 90°.
- Once the Flex-Mount splices are installed in the cable tray system, the distance between the splice mounting surfaces should be measured. Cut support rung to the measured distance and install using the hardware included. Torque to 18 ft•lbs.

For Tray Width in. (mm)	Catalog No.	Actual Rung Length in. (mm)
Up to 12 (Up to 305)	9A-RFM-12RK	20" (508)
18 & 24 (453 to 609)	9A-RFM-24RK	37" (940)
30 & 36 (762 to 914)	9A-RFM-36RK	54" (1448)

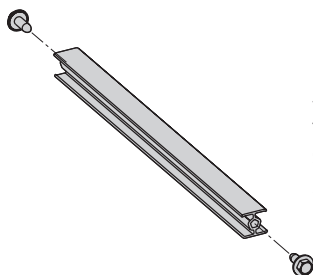

Example: Flex connectors are installed on an 18" (452mm) wide tray with approximately a 45° bend. The correct support rung kit is 9A-RFM-24RK. The tray width is 24" (609mm) or less and the angle is less than 90°.

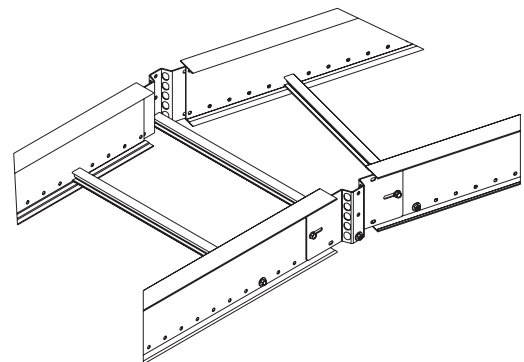

Data Cables

The National Electrical Code allows for 50% fill of ventilated cable tray for control or signal wiring (Article 392-9(b)). This rule requires that all the individual cable cross-sectional areas added up may not exceed one half the cable tray area.

The cable tray area is equal to the width times the load depth.

In actual practice with data cables, however, the cable tray becomes completely full in reaching the "50% cable fill".

The tray is completely full, but the sum of the cable areas is only 50% of the tray area, due to the empty spaces between the cables.

Data Cable Fill and Weight Chart

Number of Category 5/5e/6 Cables and Calculated Cable Weight in Lbs/Ft

Tray Depth in (mm)	Tray Width													
	6" (152mm)		9" (228mm)		12" (305mm)		18" (457mm)		24" (609mm)		30" (762mm)		36" (914mm)	
	Cables	lbs/ft	Cables	lbs/ft	Cables	lbs/ft	Cables	lbs/ft	Cables	lbs/ft	Cables	lbs/ft	Cables	lbs/ft
4" (101)	347	9	520	13	693	18	1040	27	1386	35	1733	43	2079	54
6" (152)	520	14	780	20	1040	27	1559	41	2079	52	2599	64	3119	81

This chart was based on 50% fill of 4 UTP Category 5, 5e, or 6 cables (O.D. = .21" .026 lbs/ft). In the above loading grid, the weight of the cables is not the issue. The volume capacity of the tray governs. For example, the worst case (6" load depth, 36" wide) has a total cable weight of 81 lbs/ft.

KwikRail Aluminum Cable Tray - Fittings

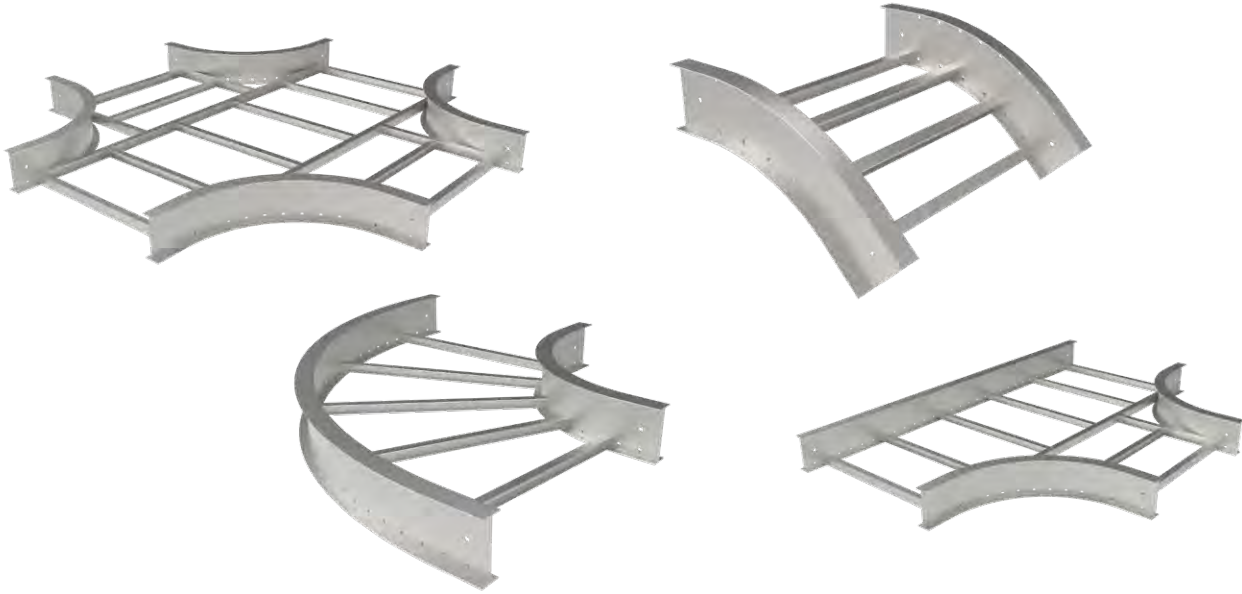

Note: All fittings are only offered in welded assembly

Fittings engineered with 3" tangents for splicing integrity.

KwikRail Cable Tray

Fitting Part Numbering

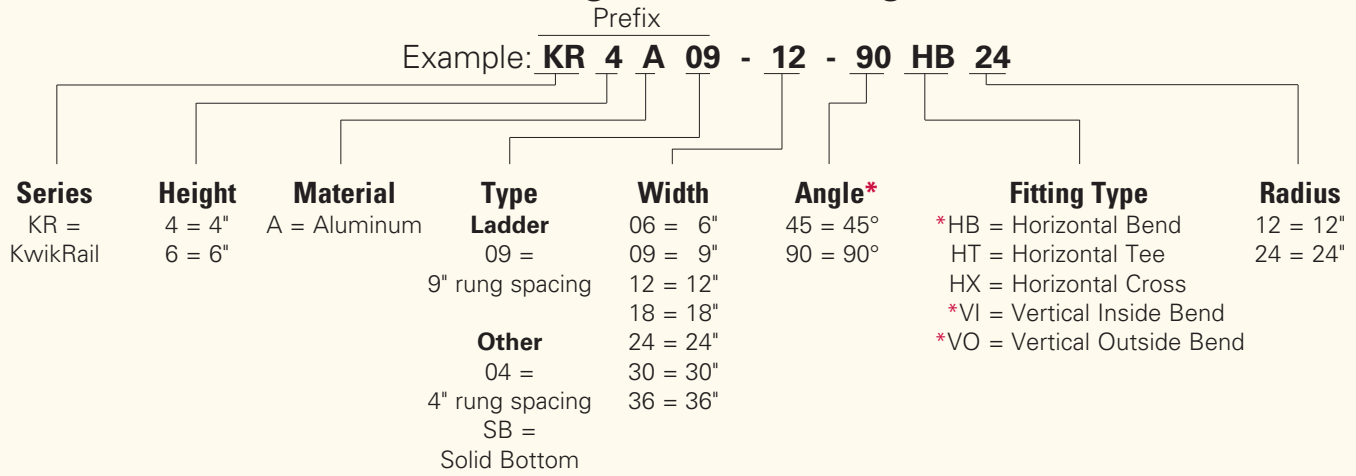

* Angle only required for HB, VI and VO fittings.

For ventilated or solid bottom, add 04 or SB as shown below: Available 6" thru 36"

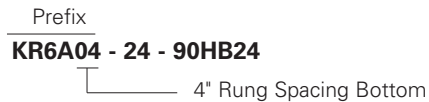

All dimensions in parentheses are millimeters unless otherwise specified.

KwikRail Aluminum Cable Tray - Fittings

Horizontal Bend 90° 45° (HB)

1 pair splice plates with hardware included.



90° Horizontal Bend



45° Horizontal Bend

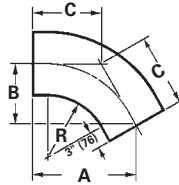
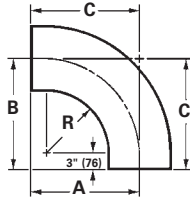

Bottoms manufactured:

Ladder = 9" Rung Spacing

04 = 4" Rung Spacing

SB = Flat sheet over 9" Rung Spacing

Bend Radius R in. (mm)	Tray Width in. (mm)	90° Horizontal Bend Dimensions				45° Horizontal Bend Dimensions			
		Catalog No.	A in. (mm)	B in. (mm)	C in. (mm)	Catalog No.	A in. (mm)	B in. (mm)	C in. (mm)
12 (305)	6 (152)	(Pre)-06-90HB12	18 (457)	18 (457)	18 (457)	(Pre)-06-45HB12	15 ³ / ₄ (400)	6 ¹ / ₂ (165)	9 ³ / ₁₆ (233)
	9 (228)	(Pre)-09-90HB12	19 ¹ / ₂ (495)	19 ¹ / ₂ (495)	19 ¹ / ₂ (495)	(Pre)-09-45HB12	16 ¹³ / ₁₆ (427)	6 ¹⁵ / ₁₆ (176)	9 ¹³ / ₁₆ (249)
	12 (305)	(Pre)-12-90HB12	21 (533)	21 (533)	21 (533)	(Pre)-12-45HB12	17 ⁷ / ₈ (454)	7 ³ / ₈ (187)	10 ⁷ / ₁₆ (265)
	18 (457)	(Pre)-18-90HB12	24 (610)	24 (610)	24 (610)	(Pre)-18-45HB12	20 (508)	8 ¹ / ₄ (210)	11 ¹¹ / ₁₆ (297)
	24 (610)	(Pre)-24-90HB12	27 (686)	27 (686)	27 (686)	(Pre)-24-45HB12	22 ¹ / ₁₆ (560)	9 ¹ / ₈ (232)	12 ¹⁵ / ₁₆ (329)
	30 (762)	(Pre)-30-90HB12	30 (762)	30 (762)	30 (762)	(Pre)-30-45HB12	22 ¹ / ₁₆ (560)	9 ¹ / ₈ (232)	12 ¹⁵ / ₁₆ (329)
	36 (914)	(Pre)-36-90HB12	33 (838)	33 (838)	33 (838)	(Pre)-36-45HB12	30 ¹ / ₂ (775)	17 ⁵ / ₈ (448)	20 ⁵ / ₁₆ (516)
24 (610)	6 (152)	(Pre)-06-90HB24	30 (762)	30 (762)	30 (762)	(Pre)-06-45HB24	24 ³ / ₁₆ (614)	10 (254)	14 ³ / ₁₆ (360)
	9 (228)	(Pre)-09-90HB24	31 ¹ / ₂ (800)	31 ¹ / ₂ (800)	31 ¹ / ₂ (800)	(Pre)-09-45HB24	25 ¹ / ₄ (641)	10 ¹ / ₂ (267)	14 ¹³ / ₁₆ (376)
	12 (305)	(Pre)-12-90HB24	33 (838)	33 (838)	33 (838)	(Pre)-12-45HB24	26 ⁵ / ₁₆ (668)	10 ¹⁵ / ₁₆ (278)	15 ⁷ / ₁₆ (392)
	18 (457)	(Pre)-18-90HB24	36 (914)	36 (914)	36 (914)	(Pre)-18-45HB24	28 ⁷ / ₁₆ (722)	11 ¹³ / ₁₆ (300)	16 ¹¹ / ₁₆ (424)
	24 (610)	(Pre)-24-90HB24	39 (991)	39 (991)	39 (991)	(Pre)-24-45HB24	30 ⁹ / ₁₆ (766)	12 ¹ / ₁₆ (322)	17 ¹⁵ / ₁₆ (456)
	30 (762)	(Pre)-30-90HB24	42 (1067)	42 (1067)	42 (1067)	(Pre)-30-45HB24	32 ¹¹ / ₁₆ (830)	13 ⁹ / ₁₆ (344)	19 ¹ / ₈ (486)
	36 (914)	(Pre)-36-90HB24	45 (1143)	45 (1143)	45 (1143)	(Pre)-36-45HB24	34 ¹³ / ₁₆ (884)	14 ⁷ / ₁₆ (367)	20 ⁹ / ₈ (518)

(Pre) = prefix. See page KR-16 for catalog number prefix.

Width dimensions are to inside wall. For aluminum fittings add 1.5 inches for total outside width.

Manufacturing tolerances apply to all dimensions.

All dimensions in parentheses are millimeters unless otherwise specified.

Horizontal Tee (HT)

2 pair splice plates with hardware included.

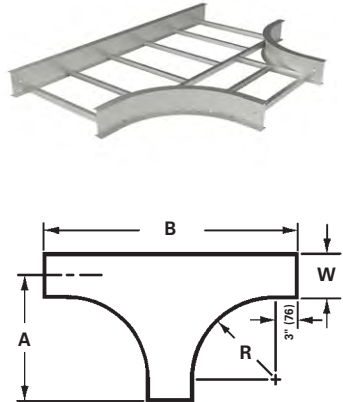

Horizontal Cross (HX)

3 pair splice plates with hardware included.

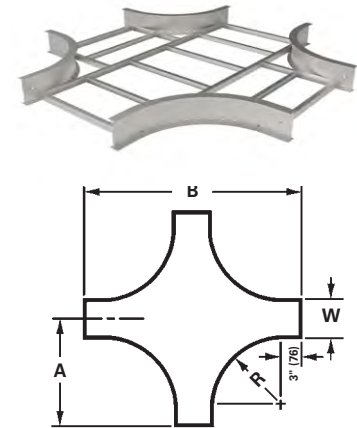

Bend Radius R in. (mm)	Tray Width in. (mm)	Horizontal Tee Dimensions			Horizontal Cross Dimensions		
		Catalog Number	A in. (mm)	B in. (mm)	Catalog Number	A in. (mm)	B in. (mm)
12 (305)	6 (152)	(Prefix)-06-HT12	18 (457)	36 (914)	(Prefix)-06-HX12	18 (457)	36 (914)
	9 (229)	(Prefix)-09-HT12	19½ (496)	39 (991)	(Prefix)-09-HX12	19½ (496)	39 (991)
	12 (305)	(Prefix)-12-HT12	21 (533)	42 (1067)	(Prefix)-12-HX12	21 (533)	42 (1067)
	18 (457)	(Prefix)-18-HT12	24 (609)	48 (1219)	(Prefix)-18-HX12	24 (609)	48 (1219)
	24 (609)	(Prefix)-24-HT12	27 (686)	54 (1372)	(Prefix)-24-HX12	27 (686)	54 (1372)
	30 (762)	(Prefix)-30-HT12	30 (762)	60 (1524)	(Prefix)-30-HX12	30 (762)	60 (1524)
	36 (914)	(Prefix)-36-HT12	33 (838)	66 (1676)	(Prefix)-36-HX12	33 (838)	66 (1676)
24 (610)	6 (152)	(Prefix)-06-HT24	30 (762)	60 (1524)	(Prefix)-06-HX24	30 (762)	60 (1524)
	9 (229)	(Prefix)-09-HT24	31½ (800)	63 (1600)	(Prefix)-09-HX24	31½ (800)	63 (1600)
	12 (305)	(Prefix)-12-HT24	33 (838)	66 (1676)	(Prefix)-12-HX24	33 (838)	66 (1676)
	18 (457)	(Prefix)-18-HT24	36 (914)	72 (1828)	(Prefix)-18-HX24	36 (914)	72 (1828)
	24 (609)	(Prefix)-24-HT24	39 (991)	78 (1982)	(Prefix)-24-HX24	39 (991)	78 (1982)
	30 (762)	(Prefix)-30-HT24	42 (1067)	84 (2134)	(Prefix)-30-HX24	42 (1067)	84 (2134)
	36 (914)	(Prefix)-36-HT24	45 (1143)	90 (2286)	(Prefix)-36-HX24	45 (1143)	90 (2286)

(Prefix) See page KR-16 for catalog number prefix.

Width dimensions are to inside wall. For aluminum fittings add 1.5 inches for total outside width.

Manufacturing tolerances apply to all dimensions.

All dimensions in parentheses are millimeters unless otherwise specified.

KwikRail Aluminum Cable Tray - Fittings

Vertical Bend 90° (VO, VI)

1 pair splice plates with hardware included.



90° Vertical Outside

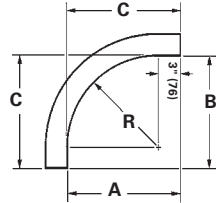

90° Vertical Inside

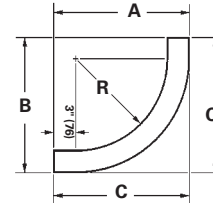

KwikRail Cable Tray

Bend Radius R	Tray Width Insert	(*) Insert "VO" for Vert. Outside Bend "VI" for Vert. Inside Bend Catalog No.	VO Side Rail Height			VI Side Rail Height						
			4" - 6" (101-152)			4" (101)			6" (152)			
in. (mm)	in. (mm)		A	B	C	A	B	C	A	B	C	
			in. (mm)	in. (mm)	in. (mm)	in. (mm)	in. (mm)	in. (mm)	in. (mm)	in. (mm)	in. (mm)	
12 (305)	6 (152)	(Prefix)-06-90(*)12										
	9 (228)	(Prefix)-09-90(*)12										
	12 (305)	(Prefix)-12-90(*)12										
	18 (457)	(Prefix)-18-90(*)12		15	15	15	19	19	19	21	21	21
	24 (609)	(Prefix)-24-90(*)12		(381)	(381)	(381)	(483)	(483)	(483)	((533)	(533)	(533)
	30 (762)	(Prefix)-30-90(*)12										
36 (914)	(Prefix)-36-90(*)12											
24 (609)	6 (152)	(Prefix)-06-90(*)24										
	9 (228)	(Prefix)-09-90(*)24										
	12 (305)	(Prefix)-12-90(*)24										
	18 (457)	(Prefix)-18-90(*)24		27	27	27	31	31	31	33	33	33
	24 (609)	(Prefix)-24-90(*)24		(686)	(686)	(686)	(787)	(787)	(787)	(838)	(838)	(838)
	30 (762)	(Prefix)-30-90(*)24										
36 (914)	(Prefix)-36-90(*)24											

(Prefix) See page KR-16 for catalog number prefix.

Manufacturing tolerances apply to all dimensions.

All dimensions in parentheses are millimeters unless otherwise specified.

KwikRail Aluminum Cable Tray - Fittings

Vertical Bend 45° (VO, VI)

1 pair splice plates with hardware included.



45° Vertical Outside



45° Vertical Inside

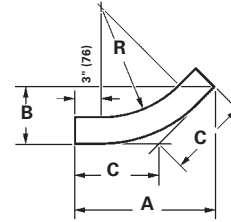
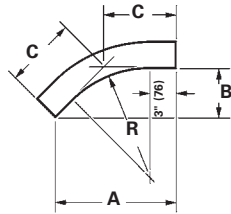

KwikRail Cable Tray

Bend Radius R	Tray Width Insert	(*) Insert "VO" for Vert. Outside Bend "VI" for Vert. Inside Bend Catalog No.	VO Side Rail Height			VI Side Rail Height					
			4" - 6" (101-152)			4" (101)			6" (127)		
in. (mm)	in. (mm)		A	B	C	A	B	C	A	B	C
			in. (mm)	in. (mm)	in. (mm)	in. (mm)	in. (mm)	in. (mm)	in. (mm)	in. (mm)	in. (mm)
12 (305)	6 (152)	(Prefix)-06-45(*)12									
	9 (228)	(Prefix)-09-45(*)12									
	12 (305)	(Prefix)-12-45(*)12									
	18 (457)	(Prefix)-18-45(*)12	13 ⁵ / ₈ (346)	5 ⁵ / ₈ (143)	8 (203)	16 ⁷ / ₁₆ (417)	6 ¹³ / ₁₆ (173)	9 ⁵ / ₈ (245)	17 ⁷ / ₈ (454)	7 ³ / ₈ (188)	10 ⁷ / ₁₆ (265)
	24 (609)	(Prefix)-24-45(*)12									
	30 (762)	(Prefix)-30-45(*)12									
36 (914)	(Prefix)-36-45(*)12										
24 (609)	6 (152)	(Prefix)-06-45(*)24									
	9 (228)	(Prefix)-09-45(*)24									
	12 (305)	(Prefix)-12-45(*)24									
	18 (457)	(Prefix)-18-45(*)24	22 ¹ / ₁₆ (561)	9 ¹ / ₈ (232)	12 ¹⁵ / ₁₆ (329)	24 ¹⁵ / ₁₆ (634)	10 ⁵ / ₁₆ (262)	14 ⁵ / ₈ (372)	26 ⁵ / ₁₆ (668)	10 ¹⁵ / ₁₆ (278)	15 ⁷ / ₁₆ (392)
	24 (609)	(Prefix)-24-45(*)24									
	30 (762)	(Prefix)-30-45(*)24									
36 (914)	(Prefix)-36-45(*)24										

(Prefix) See page KR-16 for catalog number prefix.

Manufacturing tolerances apply to all dimensions.

All dimensions in parentheses are millimeters unless otherwise specified.

Section 161xx - KwikRail Cable Tray

PART 1 GENERAL

1.01 Section Includes

- A. The work covered under this section consists of the furnishing of all necessary labor, supervision, materials, equipment, tests and services to install complete cable tray systems as shown on the drawings.
- B. Cable tray systems are defined to include, but are not limited to straight sections of of [ladder type] [vented bottom type] [solid bottom type] cable trays, bends, tees, elbows, drop-outs, supports, and accessories.

1.02 References

- A. ANSI/NFPA 70 - National Electrical Code
- B. NEMA VE 1-2009 - Metallic Cable Tray Systems
- C. NEMA VE 2-2013 - Cable Tray installation Guidelines

1.03 Drawings

- A. The drawings, which constitute a part of these specifications, indicate the general route of the cable runway systems. Data presented on these drawings is as accurate as preliminary surveys and planning can determine until final equipment selection is made. Accuracy is not guaranteed and field verification of all dimensions, routing, etc., is required.
- B. Specifications and drawings are for assistance and guidance, but exact routing, locations, distances and levels will be governed by actual field conditions. Contractor is directed to make field surveys as part of his work prior to submitting system layout drawings.

1.04 Submittals

- A. Submittal Drawings: Submit drawings of cable tray and accessories including clamps, brackets, hanger rods, splice plate connectors, expansion joint assemblies, and fittings, showing accurately scaled components.
- B. Product Data: Submit manufacturer's data on cable tray including, but not limited to, types, materials, finishes, rung spacings, inside depths and fitting radii. For side rails and rungs, submit cross sectional properties including Section Modulus (Sx) and Moment of Inertia (Ix).

1.05 Quality Assurance

- A. Manufacturers: Firms regularly engaged in manufacture of cable trays and fittings of types and capacities required, whose products have been in satisfactory use in similar service for not less than 10 years.
- B. NEMA Compliance: Comply with NEMA Standards Publication Number VE 1, "Cable Tray Systems".
- C. NEC Compliance: Comply with NEC, as applicable to construction and installation of cable tray and cable channel systems (Article 392, NEC).
- D. UL Compliance: Provide products that are UL-classified and labeled.
- E. NFPA Compliance: Comply with NFPA 70B, "Recommended Practice for Electrical Equipment Maintenance" pertaining to installation of cable tray systems.

1.06 Delivery, Storage and Handling

- A. Deliver cable tray systems and components carefully to avoid breakage, denting and scoring finishes. Do not install damaged equipment.
- B. Store cable trays and accessories in original cartons and in clean dry space; protect from weather and construction traffic. Wet materials should be unpacked and dried before storage.

PART 2 PRODUCTS

2.01 Acceptable Manufacturers

- A. Subject to compliance with these specifications, B-Line series cable tray systems shall be as manufactured by Eaton.

2.02 Cable Tray Sections and Components

- A. General: Except as otherwise indicated, provide metal cable trays, of types, classes, and sizes indicated; with splice plates, bolts, nuts, and washers for connecting units. Construct units with rounded edges and smooth surfaces; in compliance with applicable standards; and with the following additional construction features. Cable tray shall be installed according to the latest revision of NEMA VE-2.
- B. Material and Finish: Straight sections, fitting side rails, rungs and splice plates shall be extruded from Aluminum Association Alloy 6063. All fabricated parts shall be made from Aluminum Association Alloy 5052.

(continued on page KR-22)

(continued from page KRA-21)

2.03 Type of Tray System

- A. Ladder Cable Trays shall consist of two longitudinal members (side rails) with transverse members (rungs) either mechanically fastened or welded to the side rails with the option to add mechanically fastened rungs at any point along the longitudinal members. Rungs shall be spaced [6] [9] [12] inches apart. Rung spacing in radiused fittings shall be industry standard 9" maximum and measured at the center of the tray's width. Mechanically fastened rungs shall be capable of easy removal, reinstallation, or replacement if necessary.
- B. Ventilated Bottom Cable Trays shall consist of two longitudinal members (side rails) with rungs spaced 6" apart.
- C. Solid Bottom Cable Trays shall consist of two longitudinal members (side rails) with a solid sheet over rungs spaced on 12" centers.
- D. Cable tray loading depth shall be [3] [4] [5] inches per NEMA VE-1.
- E. Straight sections shall be supplied in standard [10 foot (3.05m)] [12 foot (3.65m)] lengths.
- F. Cable tray widths shall be [6] [9] [12] [18] [24] [30] [36] inches or as shown on drawings.
- G. Splice plates shall have (2) two nuts and bolts per plate. The resistance of fixed splice connections between adjacent sections of tray shall not exceed 0.00033 ohms. Splice plates shall be furnished with straight sections and fittings.
- H. All fittings must have an inside radius of [12] [24] inches.

2.04 Loading Capacities

- A. Cable trays shall meet NEMA class designation:
{NEMA 12A: [50 lbs./ft. on 12 ft. span]} OR {NEMA 12B: [75 lbs./ft. on 12 ft. span]}.
***** [OR] *****
- B. Cable tray shall be capable of carrying a uniformly distributed load of _____ lbs./ft on a _____ foot support span with a safety factor of 1.5 when supported as a simple span and tested per NEMA VE-1 Section 5.2.

PART 3 EXECUTION

3.01 Installation

- A. Install cable trays as indicated: Installation shall be in accordance with equipment manufacturer's instructions, and with recognized industry practices to ensure that cable tray equipment comply with requirements of NEC and applicable portions of NFPA 70B. Reference NEMA VE-2 for general cable tray installation guidelines.
- B. Coordinate cable tray with other electrical work as necessary to properly integrate installation of cable tray work with other work.
- C. Provide sufficient space encompassing cable trays to permit access for installing and maintaining cables.
- D. Cable tray fitting supports shall be located such that they meet the strength requirements of straight sections. Install fitting supports per NEMA VE-2 guidelines, or in accordance with manufacturer's instructions.

3.02 Testing

- A. Test cable trays to ensure electrical continuity of bonding and grounding connections, and to demonstrate compliance with specified maximum grounding resistance. See NFPA 70B, Chapter 18, for testing and test methods.
- B. Manufacturer shall provide test reports witnessed by an independent testing laboratory of the "worst case" loading conditions outlined in this specification and performed in accordance with the latest revision of NEMA VE-1-2002/CSA C22.2 No. 126.1-02.

END OF SECTION

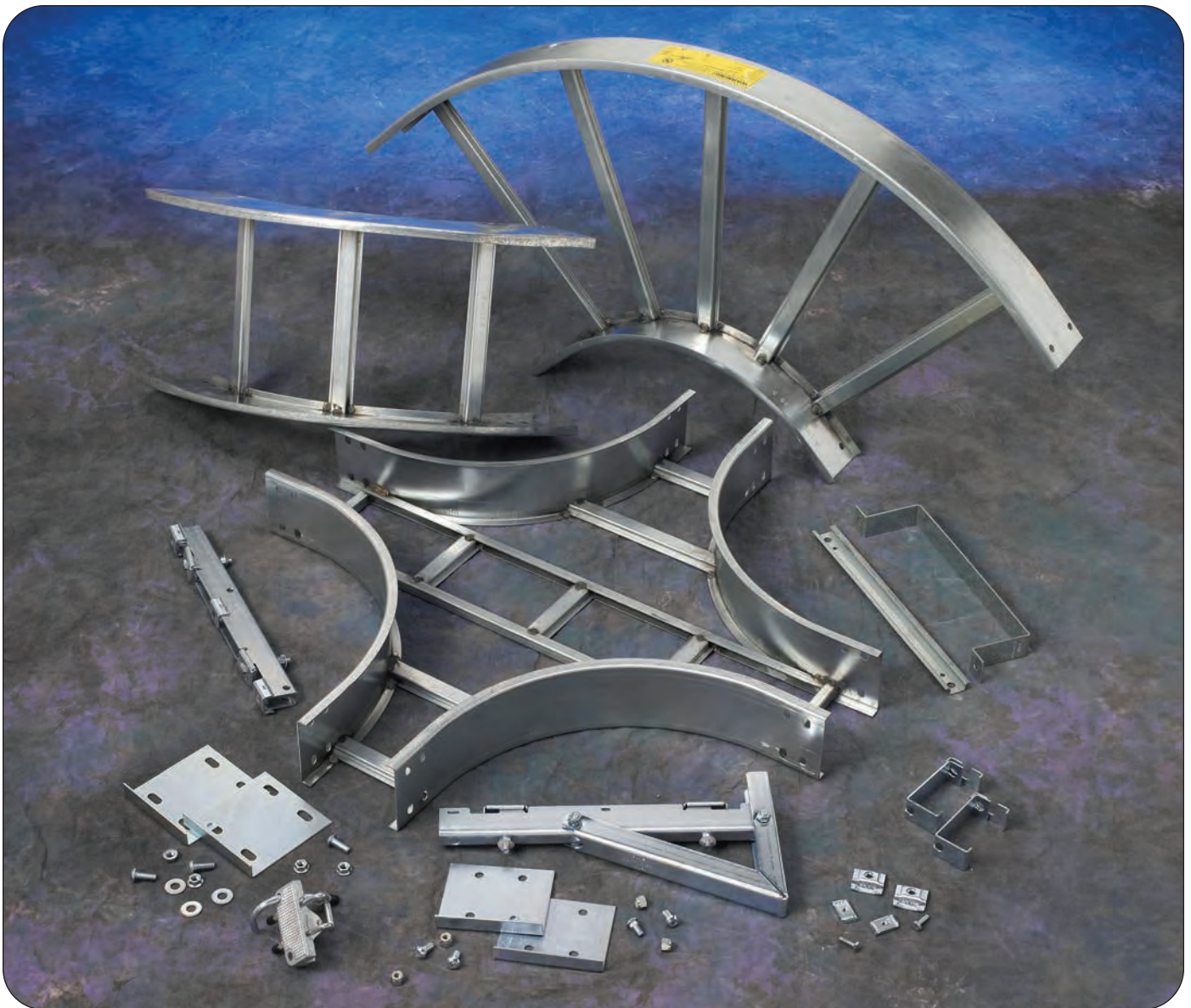

How The Service Advisor Works

We know that your time is important! That's why the color-coding system in this catalog is designed to help you select products that fit your service needs. Products are marked to indicate the typical lead time for orders of 50 pieces or less.

Customer: How do I select my straight sections, covers, or fittings so that I get the quickest turnaround?

Service Advisor: Each part of our selection chart is shown in colors. If any section of a part number is a different color, the part will typically ship with the longer lead time represented by the colors.

- Green = Fastest shipped items
- Black = Normal lead-time items
- Red = Normally long lead-time items

Example: 156G 09 - 24 - 144

● ● ● ●

● ● ● ●

Part will have a long lead time because of the 156G material.

Changing the part number from 156G to 156P will change the coding to black for all sections and reduce lead time.

3" NEMA VE 1 Loading Depth
Actual Loading Depth = 3.077"

Straight Section Part Numbering

Example: ^{Prefix} **148 P 09 - 24 - 144**

- | | | | | |
|----------------------|---|--|---|--|
| Series
148 | Material
● P = Pre-Galvanized Steel
● G = Hot Dip Galvanized After Fabrication Steel | Type
● SB = Solid Bottom
● 04 = Vented Bottom
● 06 = 6" rung spacing
● 09 = 9" rung spacing
● 12 = 12" rung spacing | Width
● 06 = 6"
● 09 = 9"
● 12 = 12"
● 18 = 18"
● 24 = 24"
● 30 = 30"
● 36 = 36" | Length
● ① 144 = 12 ft.
● ② 120 = 10 ft.

① Primary Length.
② Secondary Length.

See page C-23 for explanation of lengths. |
|----------------------|---|--|---|--|

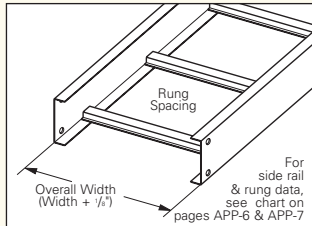

See page APP-1 for additional rung options. *SB available for all widths.

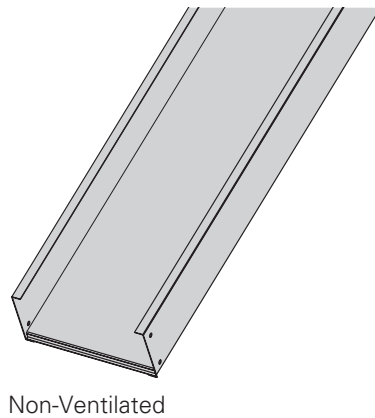
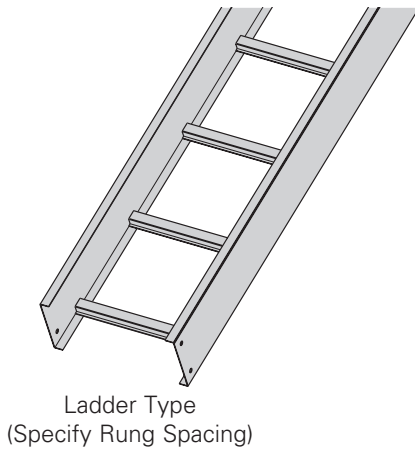

Values are based on simple beam tests per NEMA VE 1 on 36" wide cable tray with rungs spaced on 12" centers. The published load safety factor is 1.5. To convert 1.5 safety factor to 2.0, multiply the published load by 0.75. To obtain mid-span deflection, multiply a load by the deflection multiplier. Cable tray must be supported on spans shorter than or equal to the length of the cable tray being installed.

B-Line Series Side Rail Dimensions	NEMA, CSA & UL Classifications	Span ft	Load lbs/ft	Deflection Multiplier	Design Factors for Two Rails	Span meters	Load kg/m	Deflection Multiplier	Design Factors for Two Rails
	NEMA: 12A, 8C	6	204*	0.0011	Area = 0.510 in ²	1.8	304*	0.019	Area = 3.290 cm ²
	CSA: C1-3m	8	115	0.0036	Sx = 0.480 in ³	2.4	171	0.061	Sx = 7.870 cm ³
	UL Cross-Sectional	10	73	0.0087	Ix = 0.890 in ⁴	3.0	109	0.149	Ix = 37.04 cm ⁴
	Area: 0.40 in ²	12	51	0.0181		3.7	76	0.309	

*When using 12" rung spacing load capacity is limited to 195 lbs/ft (290.16 kg/m) for 36" tray width. When cable trays are used in continuous spans, the deflection of the cable tray is reduced by as much as 50%.
Design factors: Ix = Moment of Inertia, Sx = Section Modulus.

● Green = Fastest shipped items ● Black = Normal lead-time items ● Red = Normally long lead-time items

4" NEMA VE 1 Loading Depth
Actual Loading Depth = 3.628"

Straight Section Part Numbering

Prefix
Example: **156 P 09 - 24 - 144**

Series	Material	Type	Width	Length
156	<ul style="list-style-type: none"> ● P = Pre-Galvanized Steel ● G = Hot Dip Galvanized After Fabrication Steel 	<ul style="list-style-type: none"> ● SB = Solid Bottom ● 04 = Vented Bottom ● 06 = 6" rung spacing ● 09 = 9" rung spacing ● 12 = 12" rung spacing 	<ul style="list-style-type: none"> ● 06 = 6" ● 09 = 9" ● 12 = 12" ● 18 = 18" ● 24 = 24" ● 30 = 30" ● 36 = 36" 	<ul style="list-style-type: none"> ● ① 144 = 12 ft. ● ② 120 = 10 ft. <p>① Primary Length. ② Secondary Length.</p> <p>See page C-23 for explanation of lengths.</p>

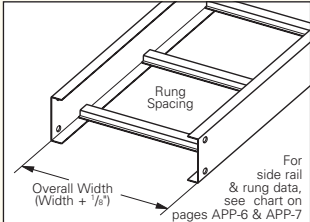

Overall Width (Width + 1/8")

Rung Spacing

For side rail & rung data, see chart on pages APP-6 & APP-7

See page APP-1 for additional rung options. *SB available for all widths.

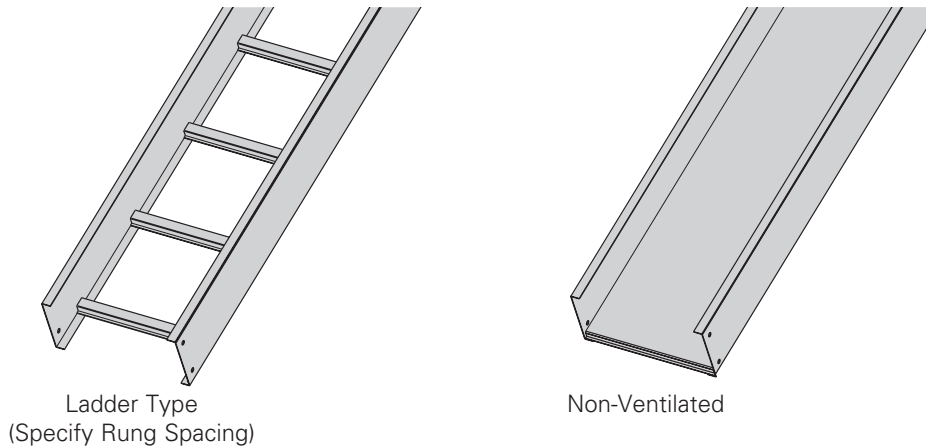

Values are based on simple beam tests per NEMA VE 1 on 36" wide cable tray with rungs spaced on 12" centers. Cable trays will support without collapse a 200 lb. (90.7 kg) concentrated load over and above the published loads. The published load safety factor is 1.5. To convert 1.5 safety factor to 2.0, multiply the published load by 0.75. To obtain mid-span deflection, multiply a load by the deflection multiplier. Cable tray must be supported on spans shorter than or equal to the length of the cable tray being installed.

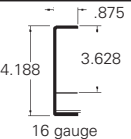
B-Line Series Slide Rail Dimensions	NEMA, CSA & UL Classifications	Span ft	Load lbs/ft	Deflection Multiplier	Design Factors for Two Rails	Span meters	Load kg/m	Deflection Multiplier	Design Factors for Two Rails
 <p>156</p>	NEMA: 12B, 8C CSA: C1-3m UL Cross-Sectional Area: 0.40 in ²	6	304*	0.0007	Area = 0.690 in ² Sx = 0.724 in ³ Ix = 1.517 in ⁴	1.8	452*	0.011	Area = 4.390 cm ² Sx = 11.860 cm ³ Ix = 63.140 cm ⁴
		8	171	0.0021		2.4	254	0.036	
		10	109	0.0051		3.0	163	0.087	
		12	76	0.0011		3.7	113	0.181	

*When using 12" rung spacing, load capacity is limited to 234 lbs/ft (348.192 kg/m) for 30" tray width and 195 lbs/ft (290.16 kg/m) for 36" tray width. When trays are used in continuous spans, the deflection of the tray is reduced by as much as 50%. Design factors: Ix = Moment of Inertia, Sx = Section Modulus.

● Green = Fastest shipped items ● Black = Normal lead-time items ● Red = Normally long lead-time items

All dimensions in parentheses are millimeters unless otherwise specified.

5" NEMA VE 1 Loading Depth

Actual Loading Depth = 4.628"

Straight Section Part Numbering

Prefix
Example: **166 P 09 - 24 - 144**

Series
166

Material
 ● **P** = Pre-Galvanized Steel
 ● **G** = Hot Dip Galvanized After Fabrication Steel

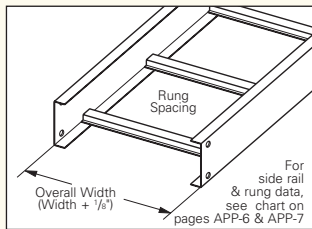

Type
 ● **SB** = Solid Bottom
 ● **04** = Vented Bottom
 ● **06** = 6" rung spacing
 ● **09** = 9" rung spacing
 ● **12** = 12" rung spacing

Width
 ● **06** = 6"
 ● **09** = 9"
 ● **12** = 12"
 ● **18** = 18"
 ● **24** = 24"
 ● **30** = 30"
 ● **36** = 36"

Length
 ● ① **144** = 12 ft.
 ● ② **120** = 10 ft.

Note
 ① Primary Length.
 ② Secondary Length.

See page C-23 for explanation of lengths.

See page APP-1 for additional rung options. *SB available for all widths.

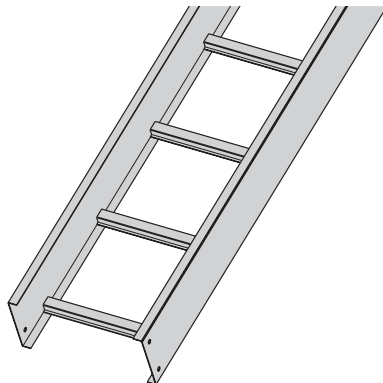

Ladder Type
(Specify Rung Spacing)

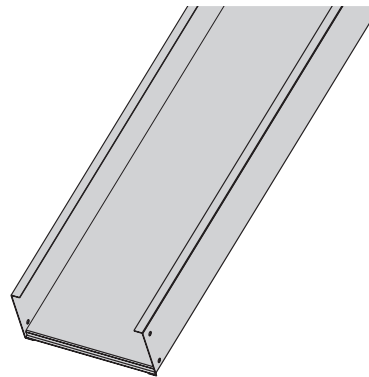

Non-Ventilated

Values are based on simple beam tests per NEMA VE 1 on 36" wide cable tray with rungs spaced on 12" centers. Cable trays will support without collapse a 200 lb. (90.7 kg) concentrated load over and above published loads. The published load safety factor is 1.5. To convert 1.5 safety factor to 2.0, multiply the published load by 0.75. To obtain mid-span deflection, multiply a load by the deflection multiplier. Cable tray must be supported on spans shorter than or equal to the length of the cable tray being installed.

B-Line Series Side Rail Dimensions	NEMA, CSA & UL Classifications	Span ft	Load lbs/ft	Deflection Multiplier	Design Factors for Two Rails	Span meters	Load kg/m	Deflection Multiplier	Design Factors for Two Rails
	NEMA: 12B, 8C CSA: C1-3m UL Cross-Sectional Area: 0.70 in ²	6	308*	0.0004	Area = 0.770 in ²	1.8	458*	0.007	Area = 4.970 cm ²
		8	173	0.0013	Sx = 0.930 in ³	2.4	258	0.023	Sx = 15.240 cm ³
		10	111	0.0032	Ix = 2.400 in ⁴	3.0	165	0.055	Ix = 99.900 cm ⁴
		12	77	0.0067		3.7	115	0.114	

*When using 12" rung spacing, the load capacity is limited to 234 lbs/ft (348.192 kg/m) for 30" tray width and 195 lbs/ft (290.16 kg/m) for 36" tray width. When trays are used in continuous spans, the deflection of the tray is reduced by as much as 50%. Design factors: Ix = Moment of Inertia, Sx = Section Modulus.

● Green = Fastest shipped items ● Black = Normal lead-time items ● Red = Normally long lead-time items

All dimensions in parentheses are millimeters unless otherwise specified.

6" NEMA VE 1 Loading Depth
Actual Loading Depth = 5.628"

Straight Section Part Numbering

Prefix
Example: **176 P 09 - 24 - 144**

<p>Series 176</p>	<p>Material</p> <ul style="list-style-type: none"> ● P = Pre-Galvanized Steel ● G = Hot Dip Galvanized After Fabrication Steel 	<p>Type</p> <ul style="list-style-type: none"> ● SB = Solid Bottom ● 04 = Vented Bottom ● 06 = 6" rung spacing ● 09 = 9" rung spacing ● 12 = 12" rung spacing 	<p>Width</p> <ul style="list-style-type: none"> ● 06 = 6" ● 09 = 9" ● 12 = 12" ● 18 = 18" ● 24 = 24" ● 30 = 30" ● 36 = 36" 	<p>Length</p> <ul style="list-style-type: none"> ● ① 144 = 12 ft. ● ② 120 = 10 ft. <p>① Primary Length. ② Secondary Length.</p> <p>See page C-23 for explanation of lengths.</p>
------------------------------	---	--	---	---

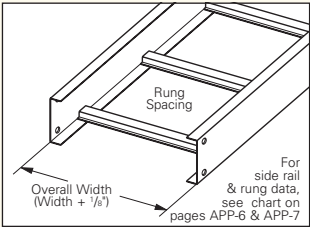

See page APP-1 for additional rung options. *SB available for all widths.

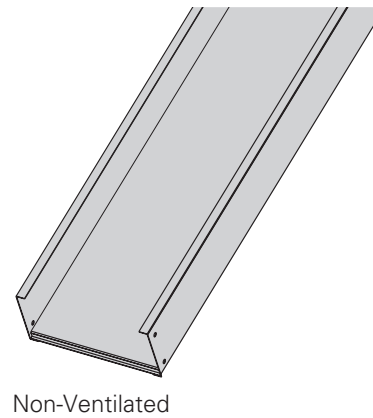
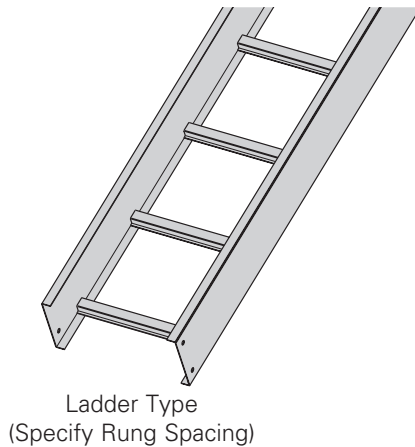

Values are based on simple beam tests per NEMA VE 1 on 36" wide cable tray with rungs spaced on 12" centers. Cable trays will support without collapse a 200 lb. (90.7 kg) concentrated load over and above published loads. The published load safety factor is 1.5. To convert 1.5 safety factor to 2.0, multiply published load by 0.75. To obtain mid-span deflection, multiply a load by the deflection multiplier. Cable tray must be supported on spans shorter than or equal to the length of the cable tray being installed.

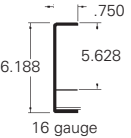
B-Line Series Slide Rail Dimensions	NEMA, CSA & UL Classifications	Span ft	Load lbs/ft	Deflection Multiplier	Design Factors for Two Rails	Span meters	Load kg/m	Deflection Multiplier	Design Factors for Two Rails
<div style="display: flex; align-items: center; justify-content: center;">  </div>	NEMA: 12B, 8C	8	194	0.0008	Area = 0.890 in ²	2.4	458*	0.014	Area = 5.740 cm ²
	CSA: 137 kg/m 3.7m	10	124	0.0020	Sx = 1.230 in ³	3.0	258	0.035	Sx = 20.160 cm ³
	UL Cross-Sectional Area: 0.70 in ²	12	86	0.0042	Ix = 3.800 in ⁴	3.7	165	0.072	Ix = 158.200 cm ⁴

When cable trays are used in continuous spans, the deflection of the tray is reduced by as much as 50%.
Design factors: Ix = Moment of Inertia, Sx = Section Modulus.

● Green = Fastest shipped items ● Black = Normal lead-time items ● Red = Normally long lead-time items

All dimensions in parentheses are millimeters unless otherwise specified.

Series 1 Steel - Accessories

Standard (L-Shaped) Splice Plates

- One pair including hardware provided with each section.
(Expansion splice quantity subtracted)
- Furnished in pairs with hardware.
- Prepackaged in pairs in a plastic bag, with hardware.
- 4-hole pattern L-shaped splice plates.
- L-shaped lay-in design.
- (*) Insert **ZN** or **G**

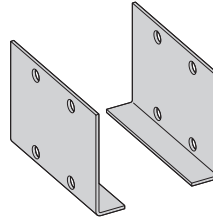

Tray Series	Catalog No.
148	9(*)-4004
156	9(*)-4005
166	9(*)-4006
176	9(*)-4007

Expansion (L-Shaped) Splice Plates

- Expansion plates allow for one inch expansion or contraction of the cable tray, or where expansion joints occur in the supporting structure.
- Bonding Jumpers are required on each side rail. Order Separately.
- L-shaped lay-in design.
- Furnished in pairs with hardware.
- (*) Insert **ZN** or **G**

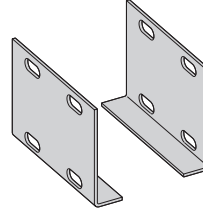

Tray Series	Catalog No.
148	9(*)-4014
156	9(*)-4015
166	9(*)-4016
176	9(*)-4017

Requires supports within 24" on both sides, per NEMA VE 2.

Universal Splice Plates

- Used to splice to existing cable tray systems.
- Furnished in pairs with hardware.
- (*) Insert **P** or **G**

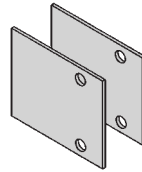

Tray Series	Catalog No.
148	9(*)-2004-1/2
156	9(*)-2005-1/2
166	9(*)-2006-1/2
176	9(*)-2007-1/2

Step Down Splice Plates

- These splice plates are offered for connecting cable tray sections having side rails of different heights.
- Furnished in pairs with hardware.
- (*) Insert **ZN** or **G**

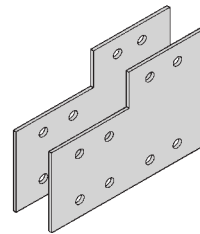

Tray Series	Catalog No.
156 to 148	9(*)-8044
166 to 156 or 148	9(*)-8045
176 to 156 or 148	9(*)-8046
176 to 166	9(*)-8060

Vertical Adjustable Splice Plates

- These plates provide for changes in elevation that do not conform to standard vertical fittings.
- Bonding jumpers not required.
- Furnished in pairs with hardware.
- (*) Insert **ZN** or **G**
- (***) Insert **P** or **G**

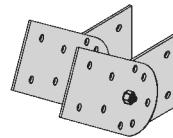

Requires supports within 24" on both sides, per NEMA VE 2.

Tray Series	Catalog No.
148	9(**)-7024
156	9(*)-8024
166	9(*)-8025
176	9(*)-8026

Horizontal Adjustable Splice Plates

- Offered to adjust a cable tray run for changes in direction in a horizontal plane that do not conform to standard horizontal fittings.
- Furnished in pairs with hardware.
- Bonding jumpers not required.
- (*) Insert **ZN** or **G**
- (X) Insert 4 for series 148 or 156, 5 for series 166, or 6 for series 176

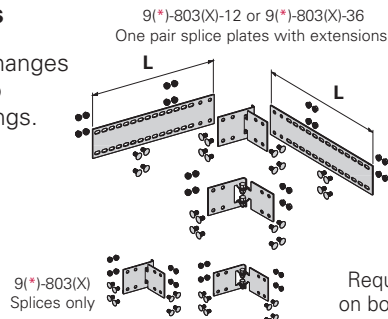

Catalog No.	Cable Tray End Cut	Tray Width	'L'
9(*)-803(X)	Mitered	Thru 36"	N/A
9(*)-803(X)-12	Not mitered	Thru 12"	16"
9(*)-803(X)-36	Not mitered	Thru 36"	41"

Requires supports within 24" on both sides, per NEMA VE 2.

● Green = Fastest shipped items ● Black = Normal lead-time items ● Red = Normally long lead-time items

All dimensions in parentheses are millimeters unless otherwise specified.

Branch Pivot Connectors

- Branch from existing cable tray runs at any point.
- Pivot to any required angle.
- UL Classified for grounding (bonding jumpers are not required).
- Furnished in pairs with hardware.
- (*) Insert **ZN** or **G**

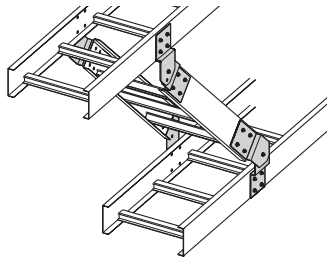

Tray Series	Catalog No.
156 to 148	9(*)-8244
166	9(*)-8245
176	9(*)-8246

Offset Reducing Splice Plate

- This plate is used for joining cable trays having different widths. When used in pairs they form a straight reduction; when used singly with a standard splice plate they form an offset reduction.
- Furnished as one plate with hardware.
- (‡) Insert reduction
- (*) Insert **P** or **G**

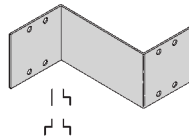

Tray Series	Catalog No.
148	9(*)-8064-(‡)
156	9(*)-8064-(‡)
166	9(*)-8065-(‡)
176	9(*)-8066-(‡)

Tray to Box Splice Plates

- Used to attach the end of a cable tray run to a distribution box or control panel.
- Furnished in pairs with hardware.
- (*) Insert **P** or **G**

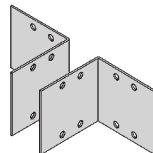

Tray Series	Catalog No.
148	9(*)-8054
156	9(*)-8054
166	9(*)-8055
176	9(*)-8056

Frame Type Box Connector

- Designed to attach the end of a cable tray run to a distribution cabinet or control center to help reinforce the box at the point of entry.
- Furnished with tray connection hardware.
- (‡) Insert tray width
- (*) Insert **ZN** or **G**

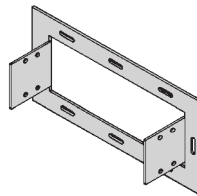

Tray Series	Catalog No.
148	9(*)-8074-(‡)
156	9(*)-8074-(‡)
166	9(*)-8075-(‡)
176	9(*)-8076-(‡)

Blind End

- This plate forms a closure for a dead end cable tray.
- Furnished as one plate with hardware.
- (‡) Insert tray width
- (*) Insert **P** or **G**

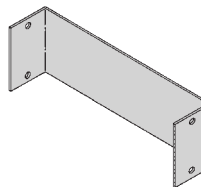

Tray Series	Catalog No.
148	9(*)-8084-(‡)
156	9(*)-8084-(‡)
166	9(*)-8085-(‡)
176	9(*)-8086-(‡)

Tray Hardware

Pre-Galvanized Tray Hardware

Catalog No. ● **RNCB 3/8"-16 x 3/4" Znplt**
Ribbed Neck Carriage Bolt ASTM A307 Grade A

Catalog No. ● **SFHN 3/8"-16 Znplt**
Serrated Flange Hex Nut ASTM A563 Grade A

Finish: Zinc Plated ASTM B633, SC1

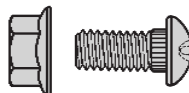

Hot Dip Galvanized Tray Hardware

Catalog No. ● **RNCB 3/8"-16 x 3/4" CZ** Ribbed Neck Carriage Bolt Chromium Zinc ASTM F-1136-88

Catalog No. ● **SFHN 3/8"-16 CZ** Serrated Flange Hex Nut Chromium Zinc ASTM F-1136-88

● Green = Fastest shipped items ● Black = Normal lead-time items ● Red = Normally long lead-time items

All dimensions in parentheses are millimeters unless otherwise specified.

Series 1 Steel - Accessories

Conduit to Tray Adaptor

- For easy attachment of conduit terminating at a cable tray.
- Use on aluminum or steel cable trays.

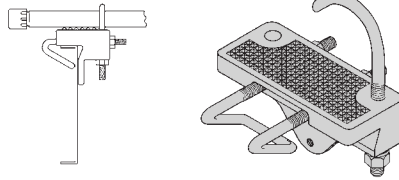

Conduit Size in. (mm)	Catalog No.
1/2, 3/4 (15, 20)	9G-1159-1/2, 3/4
1, 1 1/4 (25, 32)	9G-1159-1, 1 1/4
1 1/2, 2 (40, 50)	9G-1159-1 1/2, 2
2 1/2, 3 (65, 80)	9G-1159-2 1/2, 3
3 1/2, 4 (90, 100)	9G-1159-3 1/2, 4

Conduit to Tray Adaptor

- Assembly required.
- Mounting hardware included.
- Conduit clamp included
- (‡) = Conduit size (1/2" thru 4").

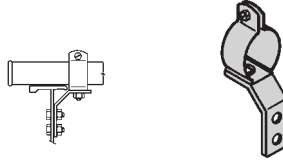

Catalog No.
9ZN-1150-(‡)

Cable Tie (Ladder Tray)

- Nylon ties provide easy attachment of cable to ladder rungs; maximum cable O.D. of 3" (76 mm).

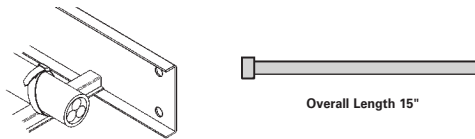

Catalog No.
99-2125-15

Cable Tray Clamp/Guide

- Features a no-twist design.
- Has four times the strength of the traditional design.
- Each side is labeled to ensure proper installation.
- Furnished in pairs, with or without hardware.

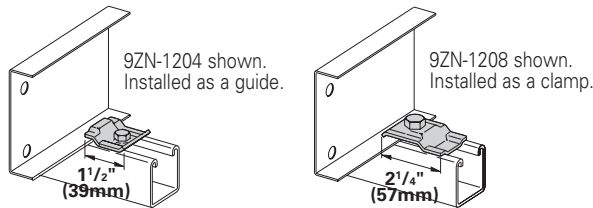

Catalog No.		Overall Length in. (mm)	Hardware Size	Finish
Without Hardware	With Hardware			
9ZN-1204	9ZN-1204NB	1 1/2 38	1/4"	G90
9ZN-1208	9ZN-1208NB	2 1/4 57	3/8"	G90

Patent # RE35479

Bonding Jumper

Use at each expansion splice and where the cable tray is not mechanically/electrically continuous to ground. Sold individually.

- Hardware included.
- See table 392.7(B)(2) on page C-9 for amperage ratings required to match the UL cross-sectional area of the tray.
- 600 amp rating.
- Bonding jumper is 14 1/2" (368mm) long.

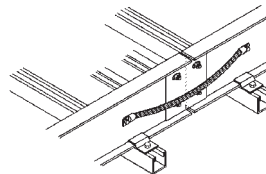

Catalog No.	Copper Wire Size
99-N1	#1

Grounding Clamp

Eaton's B-Line series cable tray is UL® classified as to its suitability as an equipment grounding conductor. If a separate conductor for additional grounding capability is desired, we offer this clamp for bolting the conductor at least once to each tray section.

- Tin plated Aluminum clamp accepts #6 AWG to 250 MCM.

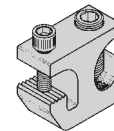

Catalog No.
9A-2130

Ground Wire Clamp

- Mechanically attaches grounding cables to cable tray.
- Hardware included.
- (*) Insert **ZN** or **SS4**

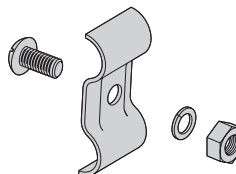

Catalog No.	Cable Size
9(*)-2351	#1 thru 2/0
9(*)-2352	3/0 thru 250 MCM

● Green = Fastest shipped items ● Black = Normal lead-time items ● Red = Normally long lead-time items

All dimensions in parentheses are millimeters unless otherwise specified.

Threaded Rod (ATR) & Rod Coupling

- Loading based on safety factor 5.
- Standard Finish: Zinc plated

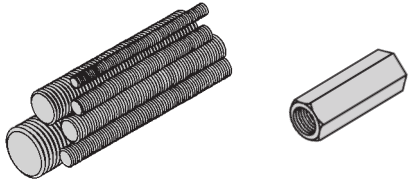

Size	Loading lbs. (kN)	Threaded Rod Catalog No.	Available Lengths in. (mm)	Coupling Cat. No.
3/8-16	730 (3.25)	● ATR 3/8 x Length	36, 72, 120, 144 (914, 1829, 3048, 3657)	● B655-3/8
1/2-13	1350 (6.00)	● ATR 3/8 x Length	36, 72, 120, 144 (914, 1829, 3048, 3657)	● B655-1/2

See B-Line series Strut Systems Catalog for other sizes and finishes.

Hanger Rod Clamp

- For 1/2" ATR.
- Furnished in pairs.
- Order ATR and hex nuts separately.
- Two piece "J"-hanger design.
- 9ZN-1113 has 275 lbs./pair safety factor 3.
- 9ZN-532(X) has 1500 lbs./pair safety factor 3.

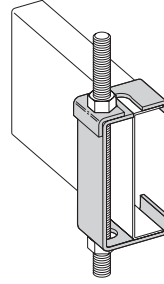

Tray Series	Catalog No.
148	● 9ZN-1113
156	● 9ZN-5324
166	● 9ZN-5325
176	● 9ZN-5326

Support Bracket

- Designed for center hung or trapeze supports.
- Used with ladder or vented bottom tray only.
- Can be purchased as a wall mounted bracket.
- Load capacity is 600 lbs. (272.1 kg), safety factor 3.
- All components are zinc plated.
- 1/2" threaded rod and 1/2" hex nuts not included.

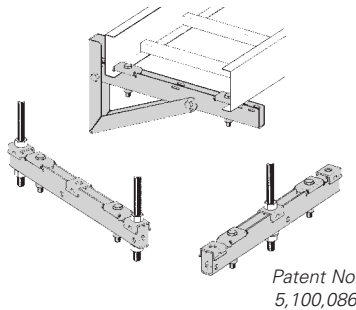

Patent No.
5,100,086

Catalog No.		For Cable Tray Width in. (mm)
Center Hung or Trapeze	Wall Mount	
● 9ZN-5106	● 9ZN-5106-WB	6 (152)
● 9ZN-5109	● 9ZN-5109-WB	9 (226)
● 9ZN-5112	● 9ZN-5112-WB	12 (305)
● 9ZN-5118	● 9ZN-5118-WB	18 (452)
● 9ZN-5124	● 9ZN-5124-WB	24 (609)

Cantilever Bracket (12" - 42")

- Finishes available:
● ZN ● GRN or ● HDG
- Safety Load Factor 2.5

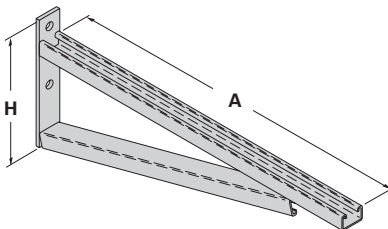

Bottom brace is B42 channel on B494-24 and smaller and B22 channel on B494-30 and larger

Catalog No.	Uniform Load lbs. (kN)	Tray Width in. (mm)	'A' in. (mm)	'H' in. (mm)
● B494-12	2500 (11.12)	6 & 9 (152 & 229)	12 (305)	8 3/4 (222)
● B494-18	1700 (7.56)	12 (305)	18 (457)	8 3/4 (222)
● B494-24	1300 (5.78)	18 (457)	24 (610)	8 3/4 (222)
B494-30	1600 (7.11)	24 (610)	30 (762)	11 1/4 (286)
B494-36	1100 (4.89)	30 (762)	36 (914)	11 1/4 (286)
B494-42	980 (4.36)	36 (914)	42 (1067)	16 (406)

For more dimensional data see Strut Systems catalog

● Green = Fastest shipped items ● Black = Normal lead-time items ● Red = Normally long lead-time items

All dimensions in parentheses are millimeters unless otherwise specified.

Series 1 Steel - Accessories

Cantilever Bracket

- Finishes available: **ZN** **GRN** **HDG** **SS4** or **SS6**
- Safety Load Factor 2.5

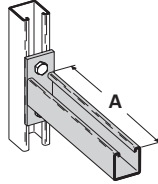

Catalog No.	Uniform Load		Tray Width		'A'	
	lbs	(kN)	in.	(mm)	in.	(mm)
B409-12	960	(4.27)	6 & 9	(152 & 229)	12	(304.8)
B409-18	640	(2.84)	12	(305)	18	(457.2)
B409-24	480	(2.13)	18	(457)	24	(609.6)

Cantilever Bracket

- Finishes available: **ZN** **GRN** **HDG** or **SS4**
- Safety Load Factor 2.5



Catalog No.	Uniform Load		Tray Width		'A'	
	lbs	(kN)	in.	(mm)	in.	(mm)
B297-30	665	(2.95)	24	(609.6)	30	(762.0)
B297-36	550	(2.44)	30	(762.0)	36	(914.4)
B297-42	465	(2.06)	36	(914.4)	42	(1066.8)

Underfloor Support (U-Bolts not included)

- Finishes available: **ZN**
- Safety Load Factor 2.5
- Order properly sized U-Bolts separately.

U-Bolt Size	Fits Pipe O.D.
B501-3/4	.841 - 1.050
B501-1	1.051 - 1.315
B501-1 1/4	1.316 - 1.660
B501-1 1/2	1.661 - 1.900
B501-2	1.901 - 2.375
B501-2 1/2	2.376 - 2.875

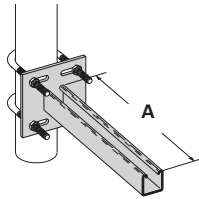

Catalog No.	Uniform Load		Tray Width		'A'	
	lbs	(kN)	in.	(mm)	in.	(mm)
B409UF-12	800	(3.55)	6 & 9	(152 & 229)	12	(304.8)
B409UF-21	450	(2.00)	12 & 18	(305 & 457)	21	(533.4)

Beam Clamp

- Finishes available: **ZN** or **HDG**
- Sold in pieces with hardware.
- Design load when used in pairs. Safety Load Factor 5.0

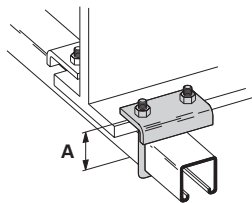

Catalog No.	Design Load*		'A'	
	lbs	(kN)	in.	(mm)
B441-22	1200	(5.34)	3 3/8	(86)
B441-22A	1200	(5.34)	5	(127)

Steel C-Clamp With Locknut

- Finishes available: **ZN** for 3/8 & 1/2
- ZN** for 5/8 & 3/4
- SS4** all sizes
- Safety Load Factor 5.0

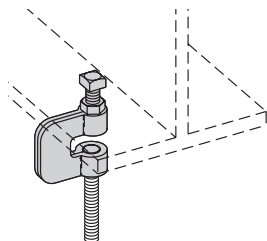

Catalog Number	Rod Size	Design Load	
		lbs	(kN)
B351L-3/8	3/8"-16	300	(0.89)
B351L-1/2	1/2"-13	380	(1.69)
B351L-5/8	5/8"-11	550	(2.44)
B351L-3/4	3/4"-10	630	(2.80)

● Green = Fastest shipped items ● Black = Normal lead-time items ● Red = Normally long lead-time items

All dimensions in parentheses are millimeters unless otherwise specified.

Beam Clamp

- Finishes available: **ZN** **GRN** or **HDG**
- Setscrew included.
- Sold in pieces.
- Design load when used in pairs.
Safety Load Factor 5.0

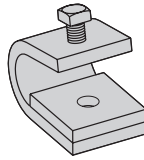

Cat. No.	B210	B210A
Design Load	800 lbs. (3.56kN)	300 lbs. (1.33kN)
Tap Size	1/2"-13	3/8"-16
Mat'l. Thickness	3/8" (9.5mm)	1/4" (6.4mm)

Beam Clamp

- Finishes available: **ZN** **GRN** or **HDG**
- Setscrew included.
- Sold in pieces.
- Design load when used in pairs.
Safety Load Factor 5.0

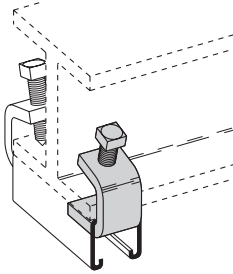

Cat. No.	B212-1/4	B212-3/8
Design Load	800 lbs. (3.56kN)	1000 lbs. (4.45kN)
Max. Flange Thick.	3/4" (19.0mm)	1 1/8" (28.6mm)
Mat'l. Thickness	1/4" (6.4mm)	3/8" (9.5mm)

B305 Thru B308 & B321 Series Beam Clamps

- Finishes available: **ZN** or **HDG**
- Setscrew included.
- Safety Load Factor 5.0

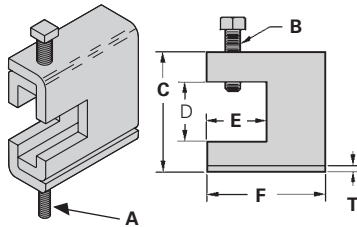

Cat. No.	A	B	C	D	E	F	T	Design Load
			in. (mm)	in. (mm)	in. (mm)	in. (mm)	in. (mm)	lbs (kN)
B305	3/8"-16	3/8"-16	2 5/16 (58.7)	7/8 (22.2)	1 1/8 (28.6)	2 1/2 (63.5)	11 Ga. (3.0)	600 (2.67)
B306	3/8"-16	1/2"-13	2 7/16 (61.9)	7/8 (22.2)	1 1/8 (28.6)	2 1/2 (63.5)	7 Ga. (4.5)	1100 (4.90)
B307	1/2"-13	1/2"-13	2 7/16 (61.9)	7/8 (22.2)	1 1/8 (28.6)	2 1/2 (63.5)	7 Ga. (4.5)	1100 (4.90)
B308	1/2"-13	1/2"-13	2 3/16 (65.1)	7/8 (22.2)	1 1/8 (28.6)	2 1/2 (63.5)	1/4 (6.3)	1500 (6.68)
B321-1	3/8"-16	1/2"-13	3 3/16 (90.5)	1 11/16 (42.8)	1 5/8 (41.3)	3 1/4 (82.5)	1/4 (6.3)	1300 (5.79)
B321-2	1/2"-13	1/2"-13	3 3/16 (90.5)	1 11/16 (42.8)	1 5/8 (41.3)	3 1/4 (82.5)	1/4 (6.3)	1400 (6.23)

B312 Anchor Strap

- Finishes available: **ZN** or **HDG**
- For a maximum beam thickness of 3/4".
- For thicker beams, step up one flange width size.

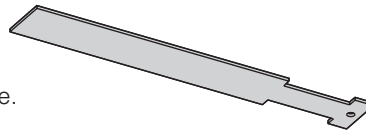

Cat. No.	Flange Width
	in. (mm)
B312-6	Up to 6 (up to 152.4)
B312-9	6 - 9 (152.4 to 228.6)
B312-12	9 - 12 (228.6 to 304.8)

B751 Bottom Beam Clamp and Accessories

- Setscrew included.
- Finish available: ZN

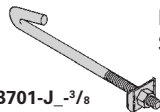

Loading position A - 500 lbs.
Loading position B - 300 lbs.
Safety Load Factor 5.0

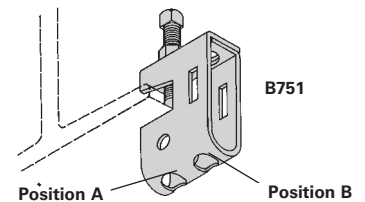
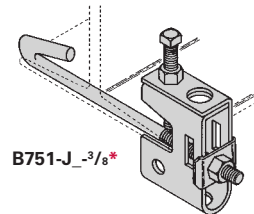

B753

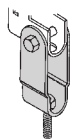

B752

Provides a full 15° swivel in any direction. (State the desired rod size.)

Assembly No.	B751	B701J_	B752	B753
Fits Flange Sizes	Clamp, Setscrew & J-Hook	J-Hook, Clip & Square Nut	Swivel & Bolt Only	Swivel Nut Only
in. (mm)				
4 - 5 7/8 (101 - 149)	● B751-J4-3/8*	● B701-J4-3/8	● B752	● B753-**
6 - 8 7/8 (152 - 225)	● B751-J6-3/8*	● B701-J6-3/8	● B752	● B753-**
9 - 11 7/8 (228 - 301)	● B751-J9-3/8*	● B701-J9-3/8	● B752	● B753-**

* Clamp Assembly complete with J-Hook Assembly. Setscrew included.

** Insert 1/4, 3/8 or 1/2 for the desired rod size.

● Green = Fastest shipped items ● Black = Normal lead-time items ● Red = Normally long lead-time items

All dimensions in parentheses are millimeters unless otherwise specified.

Series 1 Steel - Accessories

Trapeze Support Kit

Trapeze kits provide the components required for a single trapeze support in one package. These kits are available in pre-galvanized steel with zinc-plated hardware or hot dip galvanized steel with 316 stainless steel hardware.

The SH channel provides the convenience of pre-punched slots, which eliminate the need for field drilling.

The illustrated hardware is sealed in a plastic bag and boxed with the channel, which is pre-cut to the appropriate length as shown in the chart.

Designed for use with 1/2" threaded rod. (order separately)

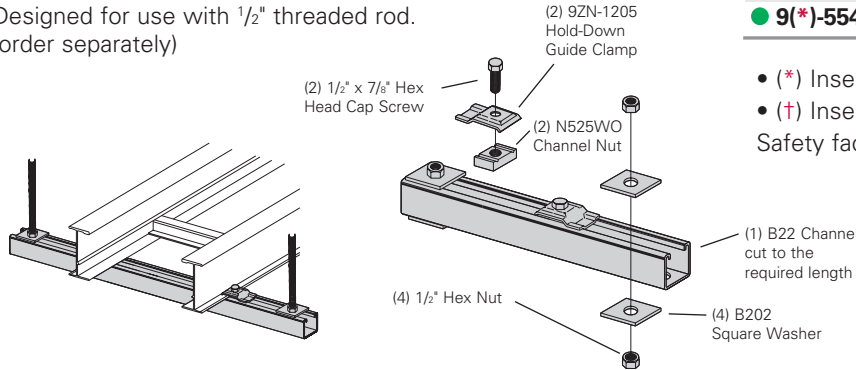

Catalog No.	Tray Width in. (mm)	Channel Length in. (mm)	Uniform Load lbs (kN)
● 9(*)-5506-22SH(†)	6 (152)	16 (406)	1600 (7.11)
● 9(*)-5509-22SH(†)	9 (229)	18 (457)	1250 (5.56)
● 9(*)-5512-22SH(†)	12 (305)	22 (559)	1125 (5.00)
● 9(*)-5518-22SH(†)	18 (457)	28 (711)	865 (3.85)
● 9(*)-5524-22SH(†)	24 (610)	34 (864)	700 (3.11)
● 9(*)-5530-22SH(†)	30 (762)	40 (1016)	590 (2.62)
● 9(*)-5536-22SH(†)	36 (914)	46 (1168)	510 (2.27)
● 9(*)-5542-22SH(†)	42 (1067)	52 (1321)	450 (2.00)

- (*) Insert **P** or **G**
- (†) Insert 3/8 for 3/8" threaded rod hardware. Safety factor of 3.0 on all loads.

Heavy Duty Trapeze Support Kit

Trapeze kits provide the components required for a single trapeze support in one package. These kits are available in Dura Green™ epoxy coated steel with zinc-plated hardware or hot dip galvanized steel with 316 stainless steel hardware.

The SH channel provides the convenience of pre-punched slots, which eliminates the need for field drilling.

The illustrated hardware is sealed in a plastic bag and boxed with the channel, which is pre-cut to the appropriate length as shown in the chart.

Designed for use with 1/2" threaded rod. (order rod separately)

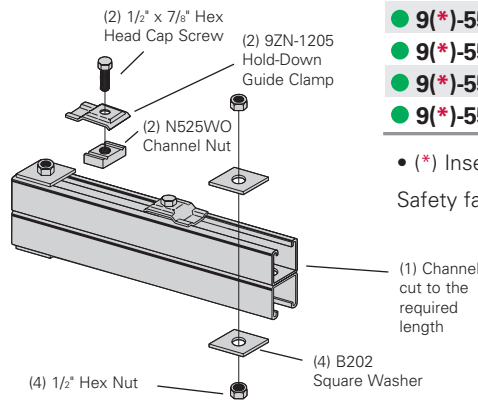

Catalog No.	Tray Width in. (mm)	Channel Length in. (mm)	Uniform Load lbs (kN)
● 9(*)-5506-22SHA	6 (152)	16 (406)	1350 (6.01)
● 9(*)-5509-22SHA	9 (229)	18 (457)	1350 (6.01)
● 9(*)-5512-22SHA	12 (305)	22 (559)	1350 (6.01)
● 9(*)-5518-22SHA	18 (457)	28 (711)	1350 (6.01)
● 9(*)-5524-22SHA	24 (610)	34 (864)	1350 (6.01)
● 9(*)-5530-22SHA	30 (762)	40 (1016)	1350 (6.01)
● 9(*)-5536-22SHA	36 (914)	46 (1168)	1350 (6.01)
● 9(*)-5542-22SHA	42 (1067)	52 (1321)	1350 (6.01)

- (*) Insert **G** or **GRN**
- Safety factor of 3.0 on all loads.

Trapeze Hardware Kit

- Kit sold in plastic bag.

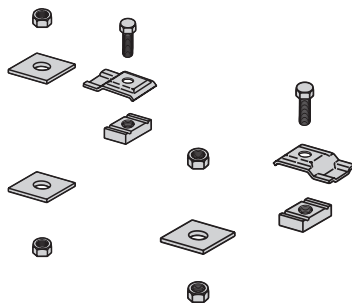

Catalog No.	
● 9ZN-5500-1/2	● 9G-5500-1/2
(1) pr. 9ZN-1205	(1) pr. 9G-1205
(2) HHC Screw 1/2" x 7/8" ZN	(2) HHC Screw 1/2" x 7/8" SS6
(2) N525 WO ZN	(2) N525 WO SS6
(4) B202 ZN 1/2" sq washer	(4) B202 HDG 1/2" sq washer
(4) HN 1/2" ZN	(4) HN 1/2" SS6

● Green = Fastest shipped items ● Black = Normal lead-time items ● Red = Normally long lead-time items

All dimensions in parentheses are millimeters unless otherwise specified.

Ladder Drop-Out

- This special designed, easy to install drop-out provides a 4" (101.6 mm) radius to protect cables exiting the cable tray from damage.
- Attaches to a ladder rung.
- Hardware included.
- (*) Insert **P** or **G**
- (‡) Insert tray width

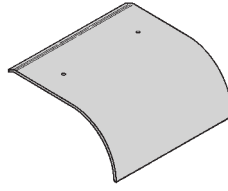

Catalog No.
9(*)-1104T-(‡)

Straight Section

- Standard length: 120" (3 m) 144" (12 ft.).
- Order catalog number based on loading depth.
- Furnished with four #10 x 1/2" plated self-drilling screws and a 99-9982 splice.
- (*) Insert **P** or **G**

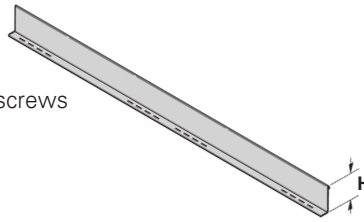

Length =
144 for 12' or 120 for 10'

Tray Series	Catalog No.	H in. (mm)
148	72(*)-Length	2.8 (58)
156	737(*)-Length	3.4 (70)
166	747(*)-Length	4.4 (91)
176	757(*)-Length	5.4 (112)

Horizontal Bend

- Horizontal Bend Barriers are flexible in order to conform to any horizontal fitting radius. Cut to length.
- Order catalog number based on loading depth.
- Furnished with three #10 x 1/2" zinc plated self-drilling screws and a 99-9982 Barrier Strip Splice.
- Standard length is 72" [6 ft.] (1829mm), sold individually.
- (*) Insert **P** or **G**

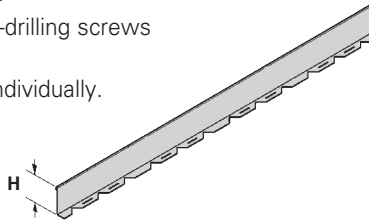

Tray Series	Catalog No.	H in. (mm)
148	72(*)-90HBFL	2.8 (58)
156	737(*)-90HBFL	3.4 (70)
166	747(*)-90HBFL	4.4 (91)
176	757(*)-90HBFL	5.4 (112)

Vertical Bend Barriers

- Vertical Bend Barriers are preformed to conform to a specific vertical fitting.
- Furnished with three #10 x 1/2" plated self-drilling screws and a 99-9982 Barrier Strip Splice.
- (*) Insert **P** or **G**
- (**) Insert 30, 45, 60 or 90 for degrees
- (†) Insert 12, 24, or 36 for radius

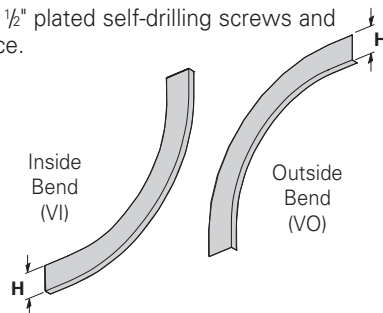

Tray Series	Catalog No.		H in. (mm)
	Inside Bend	Outside Bend	
148	72(*)-(**VI(†))	72(*)-(**VO(†))	2.8 (58)
156	737(*)-(**VI(†))	737(*)-(**VO(†))	3.4 (70)
166	747(*)-(**VI(†))	747(*)-(**VO(†))	4.4 (91)
176	757(*)-(**VI(†))	757(*)-(**VO(†))	5.4 (112)

Barrier Strip Splice

- 2.85" (72.4mm) long
- Ribbed edge for increased rigidity and grip
- Comfort edge for ease of installation
- Slotted top window with center mark for accurate placement and inspection capability
- Patent pending

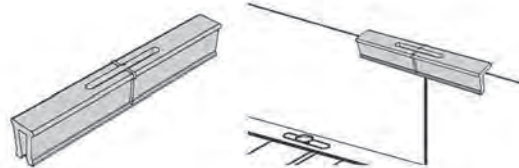

Catalog No.
● 99-9982

● Green = Fastest shipped items ● Black = Normal lead-time items ● Red = Normally long lead-time items

All dimensions in parentheses are millimeters unless otherwise specified.

Covers

Solid covers should be used when maximum enclosure of the cables is desired and no accumulation of heat is expected. **Ventilated covers** provide an overhead cable shield yet allow heat to escape.

We recommend that covers on vertical cable tray runs to a height of 6 ft. (1.83 m) to 8 ft. (2.44 m) above the floor to isolate both cables and personnel. **Flanged covers** have a .30 in. (7.6 mm) flange. Cover clamps are not included with the cover and must be ordered separately.

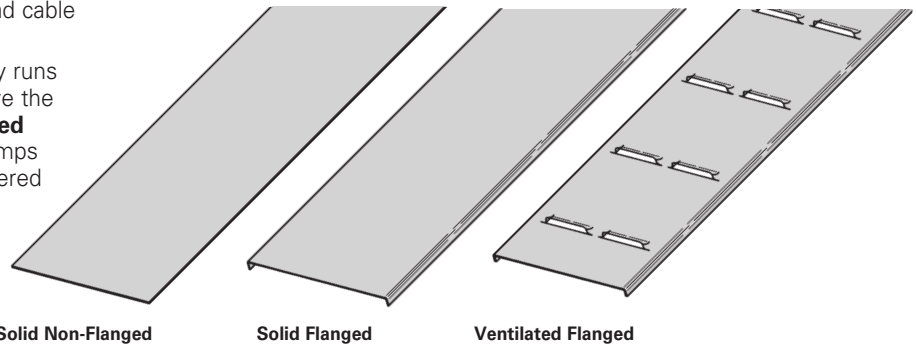

Covers Part Numbering

Prefix
Example: **80 1 P - 24 - 144**

Cover Type

- 80 = Solid
- 81 = Ventilated

Detail

- 1 = Flanged
- 9 = Non-Flanged

Material

- P = Pre-Galvanized
- G = HDGAF

Tray Width

- 06 = 6"
- 09 = 9"
- 12 = 12"
- 18 = 18"
- 24 = 24"
- 30 = 30"
- 36 = 36"

Item Description

For Straight Section Cover:

Pre-Galvanized Only:

- 144 = 12 ft. (3.66 m)
- 120 = 10 ft. (3.05 m)

Pre-Galvanized & HDGAF

- 72 = 6 ft. (1.83 m)
- 60 = 5 ft. (1.52 m)

For fitting covers: Insert suffix of fitting to be covered. See example below.

Example of Catalog Number for Fitting Cover:

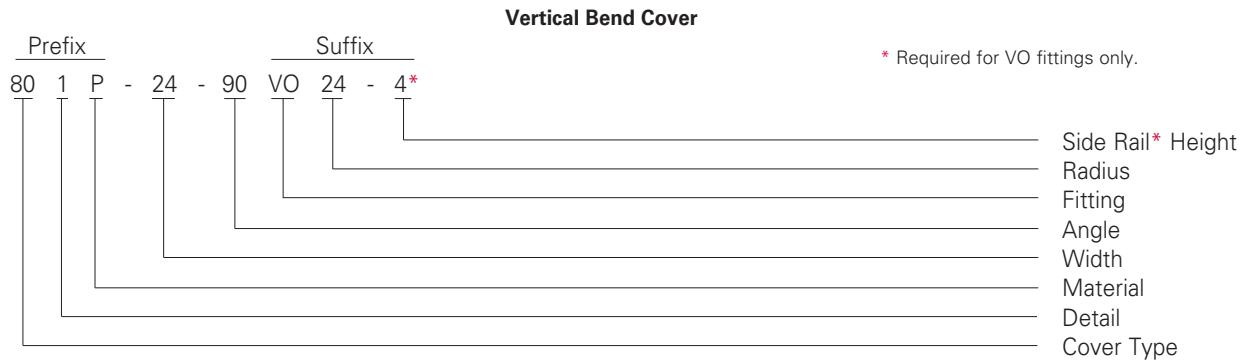

Quantity of Standard Cover Clamps Required

Straight Section 60" or 72"	4 pcs.
Straight Section 120" or 144"	6 pcs.
Horizontal/Vertical Bends	4 pcs.
Tees	6 pcs.
Crosses	8 pcs.

Note: When using the Heavy Duty Cover Clamp, only one-half the number of clamps stated above is required.

● Green = Fastest shipped items ● Black = Normal lead-time items ● Red = Normally long lead-time items

All dimensions in parentheses are millimeters unless otherwise specified.

Cover Joint Strip

- Used to join covers
- Plastic
- † Insert tray width

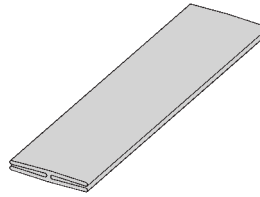

Catalog No.

● 99-9980-†

Standard Cover Clamp

- Sold per piece
- For indoor service only

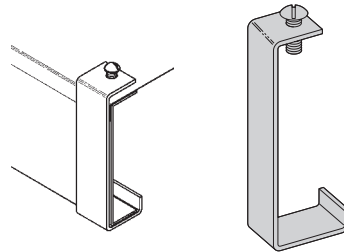

Tray Series	Catalog No.	
	Znplt	HDGAF
148	● 9ZN-9019	● 9G-9019
156	● 9ZN-9014	● 9G-9014
166	● 9ZN-9015	● 9G-9015
176	● 9ZN-9016	● 9G-9016

Combination Hold Down & Cover Clamp

- Sold per piece
- For indoor service only

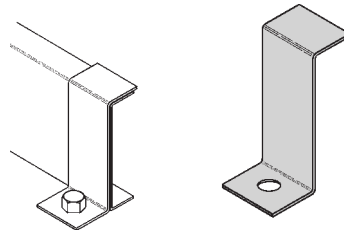

Tray Series	Catalog No.	
	Znplt/Pre-Galv	HDGAF
148	● 9ZN-9243	● 9G-9243
156	● 9P-9043	● 9G-9043
166	● 9P-9053	● 9G-9053
176	● 9P-9063	● 9G-9063

Heavy Duty Cover Clamp

- † Insert tray width

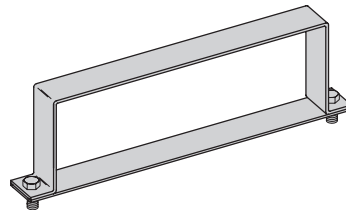

Tray Series	Catalog No.	
	Pre-Galv	HDGAF
148	● 9P-†-9040	● 9G-†-9040
156	● 9P-†-9044	● 9G-†-9044
166	● 9P-†-9054	● 9G-†-9054
176	● 9P-†-9064	● 9G-†-9064

Raised Cover Clamp

- For indoor service only.
- Sold per piece
- For use with flanged covers only.

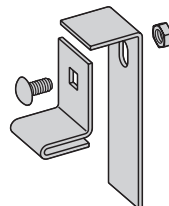

Tray Series	Catalog No.	Gap
		in. (mm)
Series 1	9ZN-9101	1 (25.4)
	9ZN-9102	2 (50.8)
	9ZN-9103	3 (76.2)
	9ZN-9104	4 (101.6)

† Specify gap of 1", 2", 3" or 4".

● Green = Fastest shipped items ● Black = Normal lead-time items ● Red = Normally long lead-time items

All dimensions in parentheses are millimeters unless otherwise specified.

Section 1- Acceptable Manufacturers

- 1.01 Manufacturer: Subject to compliance with these specifications, Eaton's B-Line series cable tray systems shall be as manufactured by Eaton.

Section 2- Cable Tray Sections and Components

- 2.01 General: Except as otherwise indicated, provide metal cable trays, of types, classes and sizes indicated; with splice plates, bolts, nuts and washers for connecting units. Construct units with rounded edges and smooth surfaces; in compliance with applicable standards; and with the following additional construction features. Cable tray shall be installed according to the latest revision of NEMA VE 2.
- 2.02 Pre-Galvanized Steel: Straight sections, fitting side rails, rungs, and covers shall be made from structural quality steel meeting the minimum mechanical properties and mill galvanized in accordance with ASTM A653 SS, Grade 33, coating designation G90. Hardware finish shall be electro-galvanized zinc per ASTM B633.
- 2.03 Hot dip Galvanized Steel: All side rails, covers, splice plates, and rungs shall be made from structural quality steel meeting the minimum mechanical properties of ASTM A1011 SS, Grade 33 for 14 gauge and heavier, ASTM A1008, Grade 33 Type 2 for 16 gauge and lighter, and shall be hot dip galvanized after fabrication in accordance with ASTM A123. Mill galvanized covers are not acceptable for hot dipped galvanized cable tray. Hardware finish shall be chromium zinc per ASTM F-1136-88.
- 2.04 Ladder Cable Trays shall consist of two longitudinal members (side rails) with transverse members (rungs) welded to the side rails. Rungs shall be spaced [6] [9] [12] inches apart. Rung spacing in radiused fittings shall be industry standard 9" and measured at the center of the tray's width. No portion of the rungs shall protrude below the bottom plane of the side rails.
- 2.06 Cable tray loading depth shall be [3] [4] [5] [6] inches per NEMA VE 1.
- 2.06 Straight sections shall be supplied in standard [12 foot] [10 foot (3 m)] lengths.
- 2.07 Cable tray widths shall be [6] [9] [12] [18] [24] [30] [36] inches or as shown on drawings.
- 2.08 Splice plates shall be L-shaped with 4 nuts and bolts per plate. The resistance of fixed splice connections between an adjacent section of tray shall not exceed 0.00033 ohm.
- 2.09 All fittings must have a minimum radius of [12] [24] inches.

Section 3- Loading Capacities and Testing

- 3.01 Cable tray shall be capable of carrying a uniformly distributed load of _____ lbs./ft. on a _____ ft. support span with a safety factor of 1.5 when supported as a simple span and tested per NEMA VE 1 5.2. Cable tray shall be made to manufacturing tolerances as specified by NEMA.
- 3.02 Upon request, manufacturer shall provide test reports in accordance with the latest revision of NEMA VE 1 or CSA C22.2 No. 126.

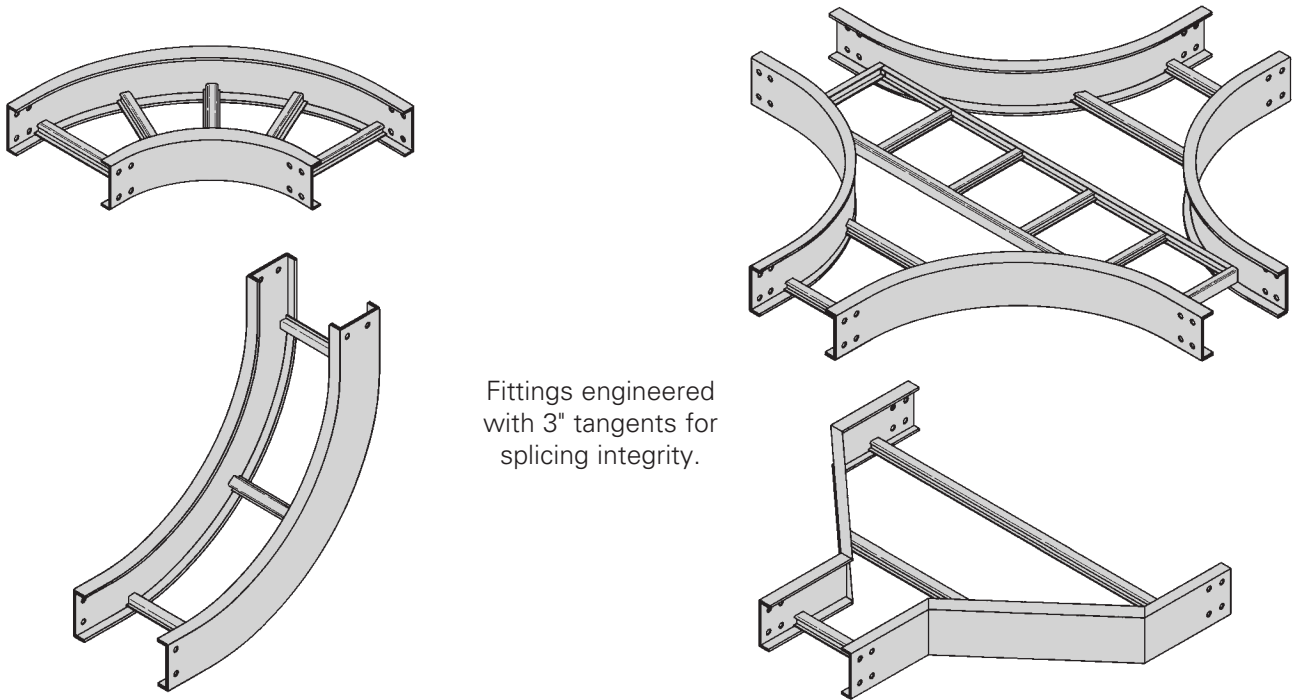

Fittings engineered with 3" tangents for splicing integrity.

Fittings Part Numbering

Example: $\overset{\text{Prefix}}{1\ 4\ P} - 24 - 90\ HB\ 24$ (9" rung spacing is standard)

Series	Height	Material	Width	Angle	Type	Radius
1	<ul style="list-style-type: none"> ● 4 = 148 ● 5 = 156 ● 6 = 166 ● 7 = 176 	<ul style="list-style-type: none"> ● P = Pre-Galvanized ● G = HDGAF 	<ul style="list-style-type: none"> ● 06 = 6" (152) ● 09 = 9" (228) ● 12 = 12" (305) ● 18 = 18" (457) ● 24 = 24" (609) ● 30 = 30" (762) ● 36 = 36" (914) 	<ul style="list-style-type: none"> ● 30 = 30° ● 45 = 45° ● 60 = 60° ● 90 = 90° 	<ul style="list-style-type: none"> ● HB = Horizontal Bend ● HT = Horizontal Tee ● HX = Horizontal Cross ● VI = Vertical Inside Bend ● VO = Vertical Outside Bend ● LR = Left Reducer ● RR = Right Reducer ● SR = Straight Reducer 	<ul style="list-style-type: none"> ● 12 = 12" (305) ● 24 = 24" (609) ● 36 = 36" (914)

For steel 4", 5", 6", 7" vented or non-ventilated add 04 or SB as shown below.

$\overset{\text{Prefix}}{15P04} - 24 - 90HB24$
 Vented Bottom

$\overset{\text{Prefix}}{15PSB} - 24 - 90HB24$
 Non-Ventilated

● Green = Fastest shipped items ● Black = Normal lead-time items ● Red = Normally long lead-time items

All dimensions in parentheses are millimeters unless otherwise specified.

Series 1 Steel - Fittings

Horizontal Bends 90° 60° 45° 30° (HB)

1 pair splice plates with hardware included.

Bottoms manufactured:
Ladder = 9" Rung Spacing
04 = 4" Rung Spacing
SB = Flat sheet over 12"
Rung Spacing

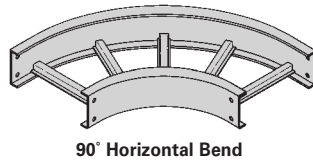

90° Horizontal Bend

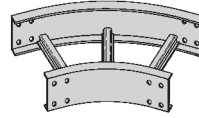

45° Horizontal Bend

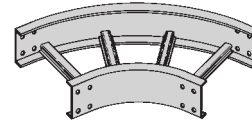

60° Horizontal Bend

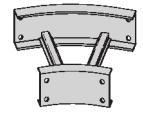

30° Horizontal Bend

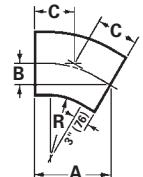
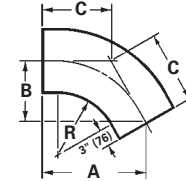
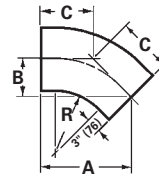
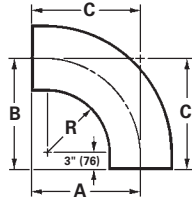

Bend Radius R	Tray Width	90° Horizontal Bend Dimensions				60° Horizontal Bend Dimensions			
		Catalog No.	A	B	C	Catalog No.	A	B	C
in. (mm)	in. (mm)		in. (mm)	in. (mm)	in. (mm)		in. (mm)	in. (mm)	in. (mm)
12 (305)	6 (152)	(Pre)-06-90HB12	18 (457)	18 (457)	18 (457)	(Pre)-06-60HB12	17 ¹ / ₂ (445)	10 ⁷ / ₈ (257)	11 ¹¹ / ₁₆ (297)
	9 (228)	(Pre)-09-90HB12	19 ¹ / ₂ (495)	19 ¹ / ₂ (495)	19 ¹ / ₂ (495)	(Pre)-09-60HB12	18 ¹³ / ₁₆ (478)	10 ⁷ / ₈ (276)	12 ¹ / ₂ (318)
	12 (305)	(Pre)-12-90HB12	21 (533)	21 (533)	21 (533)	(Pre)-12-60HB12	20 ¹ / ₁₆ (510)	11 ⁵ / ₈ (295)	13 ³ / ₈ (340)
	18 (457)	(Pre)-18-90HB12	24 (610)	24 (610)	24 (610)	(Pre)-18-60HB12	22 ¹¹ / ₁₆ (576)	13 ¹ / ₈ (333)	15 ¹ / ₈ (384)
	24 (609)	(Pre)-24-90HB12	27 (686)	27 (686)	27 (686)	(Pre)-24-60HB12	25 ⁵ / ₁₆ (643)	14 ⁵ / ₈ (372)	16 ⁷ / ₈ (429)
	30 (762)	(Pre)-30-90HB12	30 (762)	30 (762)	30 (762)	(Pre)-30-60HB12	27 ⁷ / ₈ (708)	16 ¹ / ₈ (410)	18 ⁹ / ₁₆ (472)
24 (609)	36 (914)	(Pre)-36-90HB12	33 (838)	33 (838)	33 (838)	(Pre)-36-60HB12	30 ¹ / ₂ (775)	17 ⁵ / ₈ (448)	20 ⁵ / ₁₆ (516)
	6 (152)	(Pre)-06-90HB24	30 (762)	30 (762)	30 (762)	(Pre)-06-60HB24	27 ⁷ / ₈ (708)	16 ¹ / ₈ (410)	18 ⁹ / ₁₆ (472)
	9 (228)	(Pre)-09-90HB24	31 ¹ / ₂ (800)	31 ¹ / ₂ (800)	31 ¹ / ₂ (800)	(Pre)-09-60HB24	29 ³ / ₁₆ (741)	16 ⁷ / ₈ (429)	19 ⁷ / ₁₆ (494)
	12 (305)	(Pre)-12-90HB24	33 (838)	33 (838)	33 (838)	(Pre)-12-60HB24	30 ¹ / ₂ (775)	17 ⁵ / ₈ (448)	20 ⁵ / ₁₆ (516)
	18 (457)	(Pre)-18-90HB24	36 (914)	36 (914)	36 (914)	(Pre)-18-60HB24	33 ¹ / ₁₆ (840)	19 ¹ / ₈ (486)	22 ¹ / ₁₆ (560)
	24 (609)	(Pre)-24-90HB24	39 (991)	39 (991)	39 (991)	(Pre)-24-60HB24	35 ¹¹ / ₁₆ (907)	20 ⁵ / ₈ (524)	23 ¹³ / ₁₆ (605)
12 (305)	30 (762)	(Pre)-30-90HB24	42 (1067)	42 (1067)	42 (1067)	(Pre)-30-60HB24	38 ¹ / ₄ (972)	22 ¹ / ₈ (562)	25 ¹ / ₂ (648)
	36 (914)	(Pre)-36-90HB24	45 (1143)	45 (1143)	45 (1143)	(Pre)-36-60HB24	40 ⁷ / ₈ (1038)	23 ⁵ / ₈ (600)	27 ¹ / ₄ (692)
		45° Horizontal Bend				30° Horizontal Bend			
12 (305)	6 (152)	(Pre)-06-45HB12	15 ³ / ₄ (400)	6 ¹ / ₂ (165)	9 ³ / ₁₆ (233)	(Pre)-06-30HB12	13 ¹ / ₈ (333)	3 ¹ / ₂ (89)	7 (175)
	9 (228)	(Pre)-09-45HB12	16 ¹³ / ₁₆ (427)	6 ¹⁵ / ₁₆ (176)	9 ¹³ / ₁₆ (249)	(Pre)-09-30HB12	13 ⁷ / ₈ (352)	3 ¹¹ / ₁₆ (94)	7 ⁷ / ₁₆ (189)
	12 (305)	(Pre)-12-45HB12	17 ⁷ / ₈ (454)	7 ³ / ₈ (187)	10 ⁷ / ₁₆ (265)	(Pre)-12-30HB12	14 ⁵ / ₈ (372)	3 ¹⁵ / ₁₆ (100)	7 ¹³ / ₁₆ (198)
	18 (457)	(Pre)-18-45HB12	20 (500)	8 ¹ / ₄ (210)	11 ¹¹ / ₁₆ (297)	(Pre)-18-30HB12	16 ¹ / ₈ (410)	4 ⁵ / ₁₆ (135)	8 ⁵ / ₈ (219)
	24 (609)	(Pre)-24-45HB12	22 ¹ / ₁₆ (560)	9 ¹ / ₈ (232)	12 ¹⁵ / ₁₆ (329)	(Pre)-24-30HB12	17 ⁵ / ₈ (448)	4 ¹¹ / ₁₆ (119)	9 ⁷ / ₁₆ (240)
	30 (762)	(Pre)-30-45HB12	24 ³ / ₁₆ (614)	10 (250)	14 ³ / ₁₆ (360)	(Pre)-30-30HB12	19 ¹ / ₈ (486)	5 ¹ / ₈ (130)	10 ¹ / ₄ (260)
24 (609)	36 (914)	(Pre)-36-45HB12	26 ⁵ / ₁₆ (668)	10 ¹⁵ / ₁₆ (278)	15 ⁷ / ₁₆ (392)	(Pre)-36-30HB12	20 ⁵ / ₈ (524)	5 ¹ / ₂ (140)	11 ¹ / ₁₆ (281)
	6 (152)	(Pre)-06-45HB24	24 ³ / ₁₆ (614)	10 (250)	14 ³ / ₁₆ (360)	(Pre)-06-30HB24	19 ¹ / ₈ (486)	5 ¹ / ₈ (130)	10 ¹ / ₄ (260)
	9 (228)	(Pre)-09-45HB24	25 ¹ / ₄ (641)	10 ¹ / ₂ (267)	14 ¹³ / ₁₆ (376)	(Pre)-09-30HB24	19 ⁷ / ₈ (505)	5 ⁵ / ₁₆ (135)	10 ⁵ / ₈ (270)
	12 (305)	(Pre)-12-45HB24	26 ⁵ / ₁₆ (668)	10 ¹⁵ / ₁₆ (278)	15 ⁷ / ₁₆ (392)	(Pre)-12-30HB24	20 ⁵ / ₈ (524)	5 ¹ / ₂ (140)	11 ¹ / ₁₆ (281)
	18 (457)	(Pre)-18-45HB24	28 ⁷ / ₁₆ (722)	11 ¹³ / ₁₆ (300)	16 ¹¹ / ₁₆ (424)	(Pre)-18-30HB24	22 ¹ / ₈ (562)	5 ¹⁵ / ₁₆ (151)	11 ¹³ / ₁₆ (300)
	24 (609)	(Pre)-24-45HB24	30 ⁹ / ₁₆ (776)	12 ¹¹ / ₁₆ (322)	17 ¹⁵ / ₁₆ (456)	(Pre)-24-30HB24	23 ⁵ / ₈ (600)	6 ⁵ / ₁₆ (160)	12 ⁵ / ₈ (321)
12 (305)	30 (762)	(Pre)-30-45HB24	32 ¹¹ / ₁₆ (830)	13 ⁹ / ₁₆ (345)	19 ¹ / ₈ (486)	(Pre)-30-30HB24	25 ¹ / ₈ (638)	6 ³ / ₄ (172)	13 ⁷ / ₁₆ (341)
	36 (914)	(Pre)-36-45HB24	34 ¹³ / ₁₆ (884)	14 ⁷ / ₁₆ (367)	20 ³ / ₈ (518)	(Pre)-36-30HB24	26 ⁵ / ₈ (676)	7 ¹ / ₈ (181)	14 ¹ / ₄ (362)

(Pre) See page H-18 for catalog number prefix.

Width dimensions are to inside wall. Manufacturing tolerances apply to all dimensions.

All dimensions in parentheses are millimeters unless otherwise specified.

Horizontal Tee (HT)

2 pair splice plates with hardware included.

Bend Radius R in. (mm)	Tray Width in. (mm)	Horizontal Tee Dimensions		
		Catalog No.	A in. (mm)	B in. (mm)
12 (305)	6 (152)	(Prefix)-06-HT12	18 (457)	36 (914)
	9 (228)	(Prefix)-09-HT12	19½ (495)	39 (991)
	12 (305)	(Prefix)-12-HT12	21 (533)	42 (1067)
	18 (457)	(Prefix)-18-HT12	24 (610)	48 (1219)
	24 (609)	(Prefix)-24-HT12	27 (686)	54 (1372)
	30 (762)	(Prefix)-30-HT12	30 (762)	60 (1524)
24 (609)	36 (914)	(Prefix)-36-HT12	33 (838)	66 (1676)
	6 (152)	(Prefix)-06-HT24	30 (762)	60 (1524)
	9 (228)	(Prefix)-09-HT24	31½ (800)	63 (1600)
	12 (305)	(Prefix)-12-HT24	33 (838)	66 (1676)
	18 (457)	(Prefix)-18-HT24	36 (914)	72 (1829)
	24 (609)	(Prefix)-24-HT24	39 (991)	78 (1981)
	30 (762)	(Prefix)-30-HT24	42 (1067)	84 (2134)
	36 (914)	(Prefix)-36-HT24	45 (1143)	90 (2286)

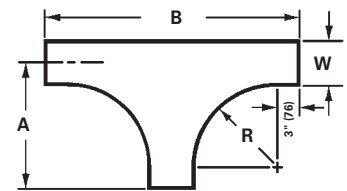
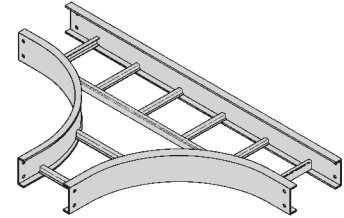

(Prefix) See page H-18 for catalog number prefix.

Horizontal Cross (HX)

3 pair splice plates with hardware included.

Bend Radius R in. (mm)	Tray Width in. (mm)	Horizontal Cross Dimensions		
		Catalog No.	A in. (mm)	B in. (mm)
12 (305)	6 (152)	(Prefix)-06-HX12	18 (457)	36 (914)
	9 (228)	(Prefix)-09-HX12	19½ (495)	39 (991)
	12 (305)	(Prefix)-12-HX12	21 (533)	42 (1067)
	18 (457)	(Prefix)-18-HX12	24 (610)	48 (1219)
	24 (609)	(Prefix)-24-HX12	27 (686)	54 (1372)
	30 (762)	(Prefix)-30-HX12	30 (762)	60 (1524)
24 (609)	36 (914)	(Prefix)-36-HX12	33 (838)	66 (1676)
	6 (152)	(Prefix)-06-HX24	30 (762)	60 (1524)
	9 (228)	(Prefix)-09-HX24	31½ (800)	63 (1600)
	12 (305)	(Prefix)-12-HX24	33 (838)	66 (1676)
	18 (457)	(Prefix)-18-HX24	36 (914)	72 (1829)
	24 (609)	(Prefix)-24-HX24	39 (991)	78 (1981)
	30 (762)	(Prefix)-30-HX24	42 (1067)	84 (2134)
	36 (914)	(Prefix)-36-HX24	45 (1143)	90 (2286)

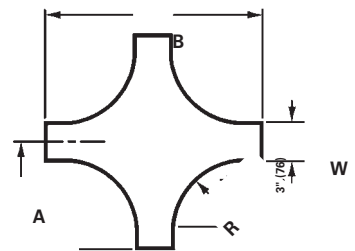
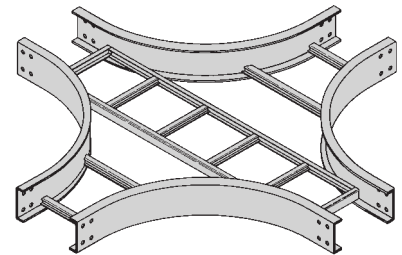

(Prefix) See page H-18 for catalog number prefix.

Width dimensions are to inside wall. Manufacturing tolerances apply to all dimensions.

All dimensions in parentheses are millimeters unless otherwise specified.

Series 1 Steel - Fittings

Reducers (LR, SR, RR)

1 pair splice plates with hardware included.

Reducer Part Numbering

14P-24-RR18

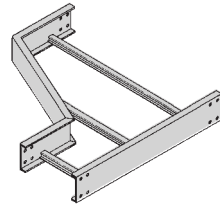
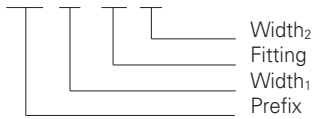

Left Reducer - LR

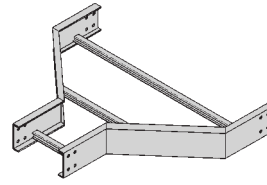

Straight Reducer - SR

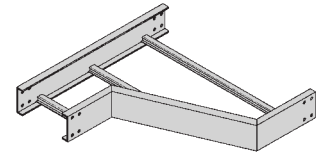

Right Reducer - RR

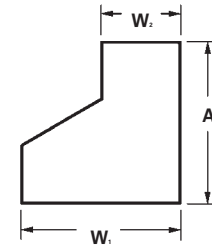
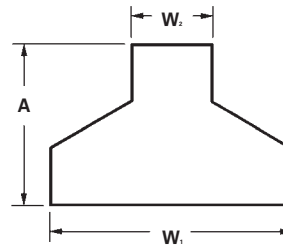
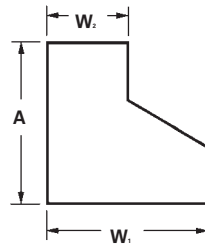

Tray Width		Left Reducer - LR		Straight Reducer - SR		Right Reducer - RR	
W ₁	W ₂	Catalog No.	A	Catalog No.	A	Catalog No.	A
in. (mm)	in. (mm)		in. (mm)		in. (mm)		in. (mm)
9 (228)	6 (152)	(Prefix)-09-LR06	9 ³ / ₄ (248)	(Prefix)-09-SR06	8 ⁷ / ₈ (225)	(Prefix)-09-RR06	9 ³ / ₄ (248)
12 (305)	6 (152)	(Prefix)-12-LR06	11 ¹ / ₂ (292)	(Prefix)-12-SR06	9 ³ / ₄ (248)	(Prefix)-12-RR06	11 ¹ / ₂ (292)
	9 (228)	(Prefix)-12-LR09	9 ³ / ₄ (248)	(Prefix)-12-SR09	8 ⁷ / ₈ (225)	(Prefix)-12-RR09	9 ³ / ₄ (248)
18 (457)	6 (152)	(Prefix)-18-LR06	14 ¹⁵ / ₁₆ (379)	(Prefix)-18-SR06	11 ¹ / ₂ (292)	(Prefix)-18-RR06	14 ¹⁵ / ₁₆ (379)
	9 (228)	(Prefix)-18-LR09	13 ³ / ₁₆ (335)	(Prefix)-18-SR09	10 ⁵ / ₈ (270)	(Prefix)-18-RR09	13 ³ / ₁₆ (335)
	12 (305)	(Prefix)-18-LR12	11 ¹ / ₂ (292)	(Prefix)-18-SR12	9 ³ / ₄ (248)	(Prefix)-18-RR12	11 ¹ / ₂ (292)
24 (609)	6 (152)	(Prefix)-24-LR06	18 ³ / ₈ (467)	(Prefix)-24-SR06	13 ³ / ₁₆ (335)	(Prefix)-24-RR06	18 ³ / ₈ (467)
	9 (228)	(Prefix)-24-LR09	16 ¹¹ / ₁₆ (424)	(Prefix)-24-SR09	12 ³ / ₈ (314)	(Prefix)-24-RR09	16 ¹¹ / ₁₆ (424)
	12 (305)	(Prefix)-24-LR12	14 ¹⁵ / ₁₆ (379)	(Prefix)-24-SR12	11 ¹ / ₂ (292)	(Prefix)-24-RR12	14 ¹⁵ / ₁₆ (379)
	18 (457)	(Prefix)-24-LR18	11 ¹ / ₂ (292)	(Prefix)-24-SR18	9 ³ / ₄ (248)	(Prefix)-24-RR18	11 ¹ / ₂ (292)
30 (762)	6 (152)	(Prefix)-30-LR06	21 ⁷ / ₈ (555)	(Prefix)-30-SR06	14 ¹⁵ / ₁₆ (379)	(Prefix)-30-RR06	21 ⁷ / ₈ (555)
	9 (228)	(Prefix)-30-LR09	20 ¹ / ₈ (511)	(Prefix)-30-SR09	14 ¹ / ₁₆ (358)	(Prefix)-30-RR09	20 ¹ / ₈ (511)
	12 (305)	(Prefix)-30-LR12	18 ³ / ₈ (467)	(Prefix)-30-SR12	13 ³ / ₁₆ (335)	(Prefix)-30-RR12	18 ³ / ₈ (467)
	18 (457)	(Prefix)-30-LR18	14 ¹⁵ / ₁₆ (379)	(Prefix)-30-SR18	11 ¹ / ₂ (292)	(Prefix)-30-RR18	14 ¹⁵ / ₁₆ (379)
	24 (609)	(Prefix)-30-LR24	11 ¹ / ₂ (292)	(Prefix)-30-SR24	9 ³ / ₄ (248)	(Prefix)-30-RR24	11 ¹ / ₂ (292)
36 (914)	6 (152)	(Prefix)-36-LR06	25 ⁵ / ₁₆ (643)	(Prefix)-36-SR06	16 ¹¹ / ₁₆ (424)	(Prefix)-36-RR06	23 ⁵ / ₁₆ (643)
	9 (228)	(Prefix)-36-LR09	23 ⁹ / ₁₆ (598)	(Prefix)-36-SR09	15 ¹³ / ₁₆ (402)	(Prefix)-36-RR09	23 ⁹ / ₁₆ (598)
	12 (305)	(Prefix)-36-LR12	21 ⁷ / ₈ (555)	(Prefix)-36-SR12	14 ¹⁵ / ₁₆ (379)	(Prefix)-36-RR12	21 ⁷ / ₈ (555)
	18 (457)	(Prefix)-36-LR18	18 ³ / ₈ (467)	(Prefix)-36-SR18	13 ³ / ₁₆ (335)	(Prefix)-36-RR18	18 ³ / ₈ (467)
	24 (609)	(Prefix)-36-LR24	14 ¹⁵ / ₁₆ (379)	(Prefix)-36-SR24	11 ¹ / ₂ (292)	(Prefix)-36-RR24	14 ¹⁵ / ₁₆ (379)
	30 (762)	(Prefix)-36-LR30	11 ¹ / ₂ (292)	(Prefix)-36-SR30	9 ³ / ₄ (248)	(Prefix)-36-RR30	11 ¹ / ₂ (292)

(Prefix) See page H-18 for catalog number prefix.

Width dimensions are to inside wall. Manufacturing tolerances apply to all dimensions.

All dimensions in parentheses are millimeters unless otherwise specified.

Vertical Bend 90° (VO, VI)

1 pair splice plates with hardware included.

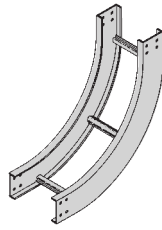
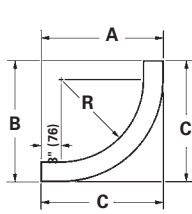

90° Vertical Inside

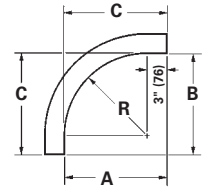
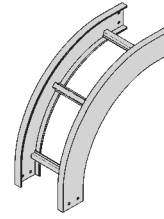

90° Vertical Outside

90° Vertical Inside Bend (VI)

Bend Radius R in. (mm)	Width in. (mm)	Catalog No.	VI Dimensions [in. (mm)]											
			Series 14 Steel			Series 15 Steel			Series 16 Steel			Series 17 Steel		
			A	B	C	A	B	C	A	B	C	A	B	C
12 (305)	6 (152)	(Pre)-06-90VI12												
	9 (228)	(Pre)-09-90VI12												
	12 (305)	(Pre)-12-90VI12												
	18 (457)	(Pre)-18-90VI12	18 ⁷ / ₁₆ (468)	18 ⁷ / ₁₆ (468)	18 ⁷ / ₁₆ (468)	19 ³ / ₁₆ (487)	19 ³ / ₁₆ (487)	19 ³ / ₁₆ (487)	20 ³ / ₁₆ (513)	20 ³ / ₁₆ (513)	20 ³ / ₁₆ (513)	21 ³ / ₁₆ (538)	21 ³ / ₁₆ (538)	21 ³ / ₁₆ (538)
	24 (609)	(Pre)-24-90VI12												
	30 (762)	(Pre)-30-90VI12												
24 (609)	6 (152)	(Pre)-06-90VI24												
	9 (228)	(Pre)-09-90VI24												
	12 (305)	(Pre)-12-90VI24												
	18 (457)	(Pre)-18-90VI24	30 ⁷ / ₁₆ (773)	30 ⁷ / ₁₆ (773)	30 ⁷ / ₁₆ (773)	31 ³ / ₁₆ (792)	31 ³ / ₁₆ (792)	31 ³ / ₁₆ (792)	32 ³ / ₁₆ (817)	32 ³ / ₁₆ (817)	32 ³ / ₁₆ (817)	33 ³ / ₁₆ (843)	33 ³ / ₁₆ (843)	33 ³ / ₁₆ (843)
	24 (609)	(Pre)-24-90VI24												
	30 (762)	(Pre)-30-90VI24												
24 (609)	6 (152)	(Pre)-06-90VI24												
	9 (228)	(Pre)-09-90VI24												
	12 (305)	(Pre)-12-90VI24												
	18 (457)	(Pre)-18-90VI24												
	24 (609)	(Pre)-24-90VI24												
	30 (762)	(Pre)-30-90VI24												

90° Vertical Outside Bend (VO)

Bend Radius R in. (mm)	Width in. (mm)	Catalog No.	VO Dimensions [in. (mm)]		
			All Series 1		
			A	B	C
12 (305)	6 (152)	(Pre)-06-90VO12			
	9 (228)	(Pre)-09-90VO12			
	12 (305)	(Pre)-12-90VO12			
	18 (457)	(Pre)-18-90VO12	15 (381)	15 (381)	15 (381)
	24 (609)	(Pre)-24-90VO12			
	30 (762)	(Pre)-30-90VO12			
24 (609)	6 (152)	(Pre)-06-90VO24			
	9 (228)	(Pre)-09-90VO24			
	12 (305)	(Pre)-12-90VO24			
	18 (457)	(Pre)-18-90VO24	27 (686)	27 (686)	27 (686)
	24 (609)	(Pre)-24-90VO24			
	30 (762)	(Pre)-30-90VO24			

(Pre) See page H-18 for catalog number prefix.

Manufacturing tolerances apply to all dimensions.

All dimensions in parentheses are millimeters unless otherwise specified.

Vertical Bend 60° (VO, VI)

1 pair splice plates with hardware included.

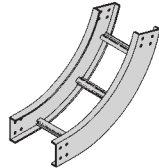
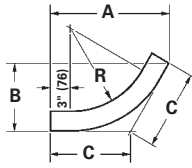

60° Vertical Inside

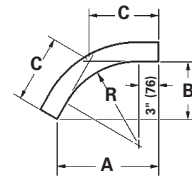
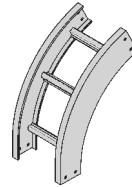

60° Vertical Outside

60° Vertical Inside Bend (VI)

Bend Radius R in. (mm)	Width in. (mm)	Catalog No.	VI Dimensions [in. (mm)]											
			Series 14 Steel			Series 15 Steel			Series 16 Steel			Series 17 Steel		
			A	B	C	A	B	C	A	B	C	A	B	C
12 (305)	6 (152)	(Pre)-06-60VI12												
	9 (228)	(Pre)-09-60VI12												
	12 (305)	(Pre)-12-60VI12												
	18 (457)	(Pre)-18-60VI12	18 ¹ / ₁₆ (459)	10 ⁷ / ₁₆ (265)	12 (305)	18 ¹ / ₂ (470)	10 ¹¹ / ₁₆ (271)	12 ³ / ₈ (314)	19 ³ / ₈ (492)	11 ³ / ₁₆ (284)	12 ¹⁵ / ₁₆ (328)	20 ¹ / ₄ (514)	11 ¹¹ / ₁₆ (297)	13 ¹ / ₂ (343)
	24 (609)	(Pre)-24-60VI12												
	30 (762)	(Pre)-30-60VI12												
24 (609)	6 (152)	(Pre)-06-60VI24												
	9 (228)	(Pre)-09-60VI24												
	12 (305)	(Pre)-12-60VI24												
	18 (457)	(Pre)-18-60VI24	28 ⁷ / ₁₆ (722)	16 ⁷ / ₁₆ (417)	18 ¹⁵ / ₁₆ (481)	28 ¹⁵ / ₁₆ (735)	18 ¹¹ / ₁₆ (424)	19 ¹ / ₄ (489)	29 ³ / ₄ (755)	17 ³ / ₁₆ (436)	19 ⁷ / ₈ (505)	30 ⁵ / ₈ (778)	17 ¹¹ / ₁₆ (449)	20 ⁷ / ₁₆ (519)
	24 (609)	(Pre)-24-60VI24												
	30 (762)	(Pre)-30-60VI24												
	36 (914)	(Pre)-36-60VI24												

60° Vertical Outside Bend (VO)

Bend Radius R in. (mm)	Width in. (mm)	Catalog No.	VO Dimensions [in. (mm)]		
			All Series 1		
			A	B	C
12 (305)	6 (152)	(Pre)-06-60VO12			
	9 (228)	(Pre)-09-60VO12			
	12 (305)	(Pre)-12-60VO12			
	18 (457)	(Pre)-18-60VO12	14 ⁷ / ₈ (378)	8 ⁵ / ₈ (219)	9 ¹⁵ / ₁₆ (252)
	24 (609)	(Pre)-24-60VO12			
	30 (762)	(Pre)-30-60VO12			
24 (609)	6 (152)	(Pre)-06-60VO24			
	9 (228)	(Pre)-09-60VO24			
	12 (305)	(Pre)-12-60VO24			
	18 (457)	(Pre)-18-60VO24	25 ⁵ / ₁₆ (643)	14 ⁵ / ₈ (371)	16 ⁷ / ₈ (428)
	24 (609)	(Pre)-24-60VO24			
	30 (762)	(Pre)-30-60VO24			
	36 (914)	(Pre)-36-60VO24			

(Pre) See page H-18 for catalog number prefix.

Manufacturing tolerances apply to all dimensions.

All dimensions in parentheses are millimeters unless otherwise specified.

Vertical Bend 45° (VO, VI)

1 pair splice plates with hardware included.

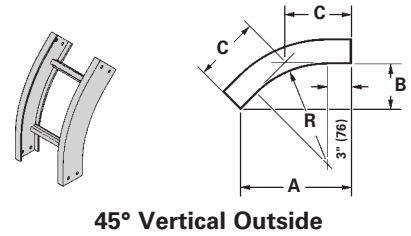
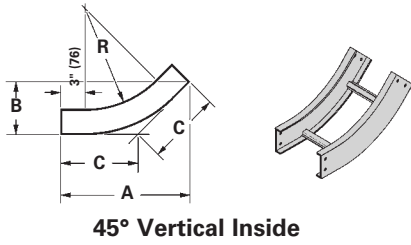

45° Vertical Inside Bend (VI)

Bend Radius R in. (mm)	Width in. (mm)	Catalog No.	VI Dimensions [in. (mm)]											
			Series 14 Steel			Series 15 Steel			Series 16 Steel			Series 17 Steel		
			A	B	C	A	B	C	A	B	C	A	B	C
12 (305)	6 (152)	(Pre)-06-45VI12												
	9 (228)	(Pre)-09-45VI12												
	12 (305)	(Pre)-12-45VI12												
	18 (457)	(Pre)-18-45VI12	16 ³ / ₁₆ (411)	6 ¹¹ / ₁₆ (170)	9 ¹ / ₂ (241)	16 ⁹ / ₁₆ (420)	6 ⁷ / ₈ (174)	9 ¹¹ / ₁₆ (246)	17 ¹ / ₄ (438)	7 ³ / ₁₆ (182)	10 ¹ / ₈ (257)	18 (457)	7 ⁷ / ₁₆ (189)	10 ⁹ / ₁₆ (268)
	24 (609)	(Pre)-24-45VI12												
	30 (762)	(Pre)-30-45VI12												
24 (609)	6 (152)	(Pre)-06-45VI24												
	9 (228)	(Pre)-09-45VI24												
	12 (305)	(Pre)-12-45VI24												
	18 (457)	(Pre)-18-45VI24	24 ¹¹ / ₁₆ (627)	10 ³ / ₁₆ (259)	14 ⁷ / ₁₆ (367)	25 ¹ / ₁₆ (792)	10 ³ / ₈ (792)	14 ¹¹ / ₁₆ (373)	25 ³ / ₄ (654)	10 ¹¹ / ₁₆ (271)	15 ¹ / ₁₆ (382)	26 ¹ / ₂ (673)	11 (279)	15 ¹ / ₂ (394)
	24 (609)	(Pre)-24-45VI24												
	30 (762)	(Pre)-30-45VI24												
	36 (914)	(Pre)-36-45VI24												

45° Vertical Outside Bend (VO)

Bend Radius R in. (mm)	Width in. (mm)	Catalog No.	VO Dimensions [in. (mm)]		
			All Series 1		
			A	B	C
12 (305)	6 (152)	(Pre)-06-45V012			
	9 (228)	(Pre)-09-45V012			
	12 (305)	(Pre)-12-45V012			
	18 (457)	(Pre)-18-45V012	13 ⁵ / ₈ (346)	5 ⁵ / ₈ (143)	8 (203)
	24 (609)	(Pre)-24-45V012			
	30 (762)	(Pre)-30-45V012			
24 (609)	6 (152)	(Pre)-06-45V024			
	9 (228)	(Pre)-09-45V024			
	12 (305)	(Pre)-12-45V024			
	18 (457)	(Pre)-18-45V024	22 ¹ / ₁₆ (560)	9 ¹ / ₈ (232)	12 ¹⁵ / ₁₆ (328)
	24 (609)	(Pre)-24-45V024			
	30 (762)	(Pre)-30-45V024			
	36 (914)	(Pre)-36-45V024			

(Pre) See page H-18 for catalog number prefix.
Manufacturing tolerances apply to all dimensions.

All dimensions in parentheses are millimeters unless otherwise specified.

Series 1 Steel - Fittings

Vertical Bend 30° (VO, VI)

1 pair splice plates with hardware included.

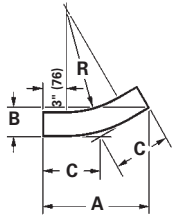

30° Vertical Inside

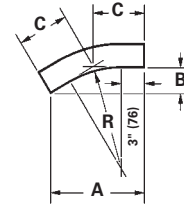
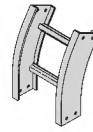
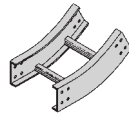

30° Vertical Outside

30° Vertical Inside Bend (VI)

Bend Radius R in. (mm)	Width in. (mm)	Catalog No.	VI Dimensions [in. (mm)]											
			Series 14 Steel			Series 15 Steel			Series 16 Steel			Series 17 Steel		
			A	B	C	A	B	C	A	B	C	A	B	C
12 (305)	6 (152)	(Pre)-06-30VI12												
	9 (228)	(Pre)-09-30VI12												
	12 (305)	(Pre)-12-30VI12												
	18 (457)	(Pre)-18-30VI12	13 ⁷ / ₁₆ (341)	3 ⁵ / ₈ (92)	7 ³ / ₁₆ (182)	13 ¹¹ / ₁₆ (347)	3 ¹¹ / ₁₆ (93)	7 ⁵ / ₁₆ (186)	14 ³ / ₁₆ (360)	3 ¹³ / ₁₆ (97)	7 ⁵ / ₈ (193)	14 ¹¹ / ₁₆ (373)	3 ¹⁵ / ₁₆ (100)	7 ⁷ / ₈ (200)
	24 (609)	(Pre)-24-30VI12												
	30 (762)	(Pre)-30-30VI12												
24 (609)	6 (152)	(Pre)-06-30VI24												
	9 (228)	(Pre)-09-30VI24												
	12 (305)	(Pre)-12-30VI24												
	18 (457)	(Pre)-18-30VI24	19 ⁷ / ₁₆ (494)	5 ³ / ₁₆ (132)	10 ⁷ / ₁₆ (265)	19 ¹¹ / ₁₆ (500)	5 ⁵ / ₁₆ (135)	10 ⁹ / ₁₆ (268)	20 ³ / ₁₆ (513)	5 ⁷ / ₁₆ (138)	10 ¹³ / ₁₆ (274)	20 ¹¹ / ₁₆ (525)	5 ⁹ / ₁₆ (141)	11 ¹ / ₁₆ (281)
	24 (609)	(Pre)-24-30VI24												
	30 (762)	(Pre)-30-30VI24												
36 (914)	(Pre)-36-30VI24													

30° Vertical Outside Bend (VO)

Bend Radius R in. (mm)	Width in. (mm)	Catalog No.	VO Dimensions [in. (mm)]		
			All Series 1		
			A	B	C
12 (305)	6 (152)	(Pre)-06-30VO12			
	9 (228)	(Pre)-09-30VO12			
	12 (305)	(Pre)-12-30VO12			
	18 (457)	(Pre)-18-30VO12	11 ⁵ / ₈ (295)	3 ¹ / ₈ (79)	6 ³ / ₁₆ (157)
	24 (609)	(Pre)-24-30VO12			
	30 (762)	(Pre)-30-30VO12			
24 (609)	6 (152)	(Pre)-06-30VO24			
	9 (228)	(Pre)-09-30VO24			
	12 (305)	(Pre)-12-30VO24			
	18 (457)	(Pre)-18-30VO24	17 ⁵ / ₈ (448)	4 ¹¹ / ₁₆ (119)	9 ⁷ / ₁₆ (240)
	24 (609)	(Pre)-24-30VO24			
	30 (762)	(Pre)-30-30VO24			
36 (914)	(Pre)-36-30VO24				

(Pre) See page H-18 for catalog number prefix.
Manufacturing tolerances apply to all dimensions.

All dimensions in parentheses are millimeters unless otherwise specified.

Vertical Bend Segments (VBS)

Adjustable Vertical Bends are made up of one or more vertical bend segments and can be used as a vertical inside (VI) or vertical outside (VO) bend. This design provides for vertical changes in direction with angles 45°, 60° and 90° for 12" (305 mm) or 24" (609 mm) radius. The chart below shows the number of segments required for the various combinations of angles and radii. The VBS-1, VBS-2 and VBS-3 include one, two or three segments respectively with splice plates and hardware. Holes for setting standard angles are pre-punched in each segment. Other angles can be set by field drilling another hole for the locking bolt.

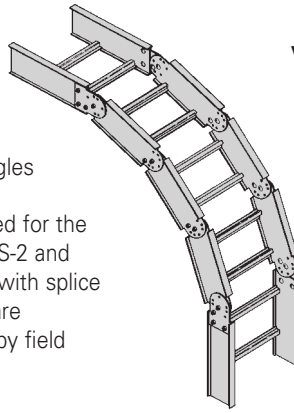

Available for **148P** and **148G** only.

Nominal Bend Radius in. (mm)	Catalog No.	Dimensions					
		VO			VI		
		A in. (mm)	B in. (mm)	R in. (mm)	A in. (mm)	B in. (mm)	R in. (mm)
90° Vertical Inside or Outside							
12 (305)	14(*)-(‡)-VBS-1	8 ¹ / ₄ (210)	8 ¹ / ₄ (210)	6 ¹ / ₂ (165)	12 ¹ / ₈ (303)	12 ¹ / ₈ (303)	10 ¹ / ₂ (267)
24 (609)	14(*)-(‡)-VBS-3	24 (610)	24 (610)	22 ¹ / ₄ (565)	27 ⁷ / ₈ (708)	27 ⁷ / ₈ (708)	26 ¹ / ₄ (667)
60° Vertical Inside or Outside							
12 (305)	14(*)-(‡)-VBS-1	11 ³ / ₄ (298)	6 ¹ / ₂ (165)	12 (305)	14 ³ / ₄ (375)	8 ¹ / ₂ (216)	16 (406)
24 (609)	14(*)-(‡)-VBS-2	11 ³ / ₄ (298)	6 ¹ / ₂ (165)	12 (305)	14 ³ / ₄ (375)	8 ¹ / ₂ (216)	16 (406)
45° Vertical Inside or Outside							
12 (305)	14(*)-(‡)-VBS-1	12 ³ / ₄ (324)	5 ¹ / ₄ (133)	17 ¹ / ₈ (435)	15 ¹ / ₂ (394)	6 ⁷ / ₈ (175)	21 (540)
24 (609)	14(*)-(‡)-VBS-1	12 ³ / ₄ (324)	5 ¹ / ₄ (133)	17 ¹ / ₈ (435)	15 ¹ / ₂ (394)	6 ⁷ / ₈ (175)	21 (540)

Notes:

- (*) Insert material type: P=Pre Galvanized, G=HDGAF
- (‡) Insert width 6, 9, 12, 18, 24, 30, 36

Fitting Hole Pattern

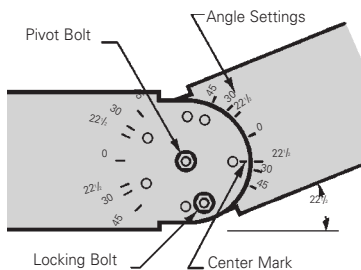

Setting the Angle

To find correct angle setting, divide angle of offset by the number of segments plus one. The result is equal to the angle setting stamped on the vertical bend segment and the splice plate. After inserting center pivot bolt, align the mark at the end of the segment or splice plate with the angle and insert locking bolt in the pre-punched hole.

Example: 90° bend, 24" radius requires 3 segments
 3 segments + 1 = 4
 90° divided by 4 = 22¹/₂°
 Set all vertical segments at 22¹/₂°

Offset Dimensions

One vertical bend segment can be used to complete a vertical offset. Offset dimensions are shown.

Angle θ	A in. (mm)	B in. (mm)
45°	12 (305)	8 ¹ / ₂ (216)
30°	14 (355)	5 ³ / ₄ (146)
22 ¹ / ₂ °	14 ¹ / ₄ (362)	5 (127)

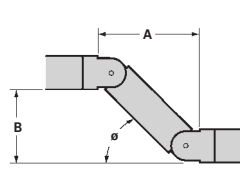

VBS-1 (1 Segment)

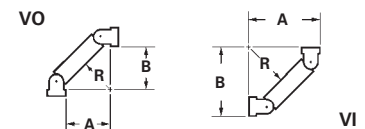

VBS-2 (2 Segments)

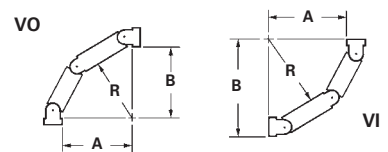

VBS-3 (3 Segments)

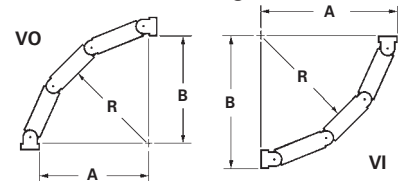

● Green = Fastest shipped items ● Black = Normal lead-time items ● Red = Normally long lead-time items

All dimensions in parentheses are millimeters unless otherwise specified.

For Aluminum Fittings
see fittings section pages
L-1 thru L-17

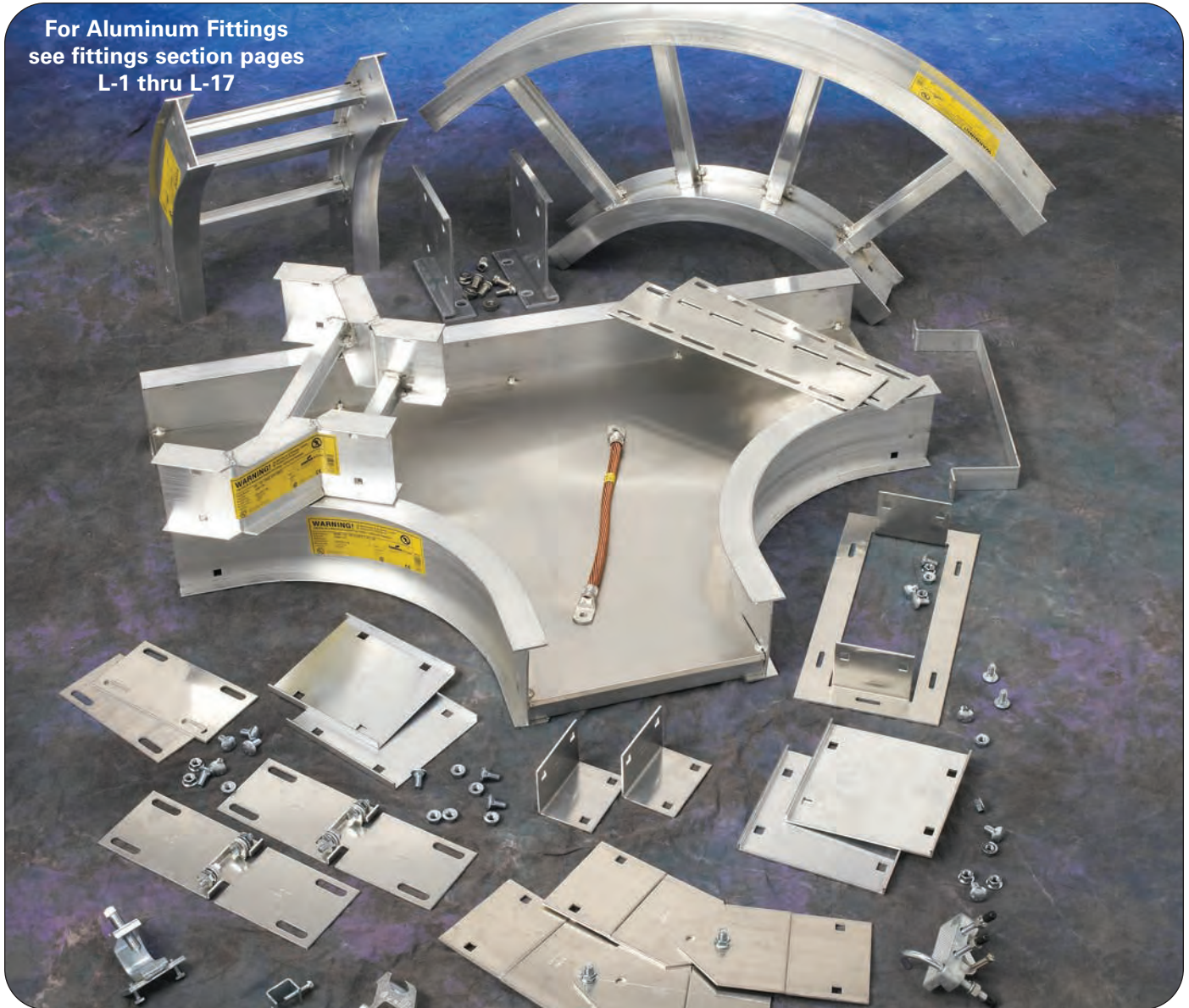

How The Service Advisor Works

We know that your time is important! That's why the color-coding system in this catalog is designed to help you select products that fit your service needs. Products are marked to indicate the typical lead time for orders of 50 pieces or less.

Customer: How do I select my straight sections, covers, or fittings so that I get the quickest turnaround?

Service Advisor: Each part of our selection chart is shown in colors. If any section of a part number is a different color, the part will typically ship with the longer lead time represented by the colors.

- Green = Fastest shipped items
- Black = Normal lead-time items
- Red = Normally long lead-time items

Example: 34A VT - 24 - 144

● ● ● ●

Part will have a normal lead time because of the VT bottom type.

**3" NEMA VE 1 Loading Depth
4" Side Rail Height**

Straight Section Part Numbering

Prefix
Example: **24 A 09 - 24 - 144**

Series

- 24
- H24
- 34

Material

- A = Aluminum

***Type**

- SB = Solid Bottom
- 06 = 6" rung spacing
- 09 = 9" rung spacing
- 12 = 12" rung spacing

***Width**

- 06 = 6"
- 09 = 9"
- 12 = 12"
- 18 = 18"
- 24 = 24"
- 30 = 30"
- 36 = 36"

Length

- ① 144 = 12 ft. 24
- ② 120 = 10 ft. 24
- ① 240 = 20 ft. H24
- ② 144 = 12 ft. H24
- ① 240 = 20 ft. 34
- ② 144 = 12 ft. 34

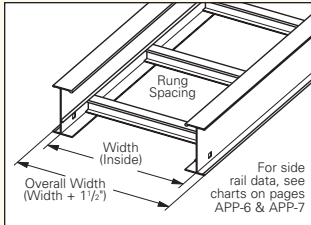

① Primary Length.
② Secondary Length.

See page C-23 for explanation of lengths.

See page APP-1 for additional rung options. *Special sizes available.

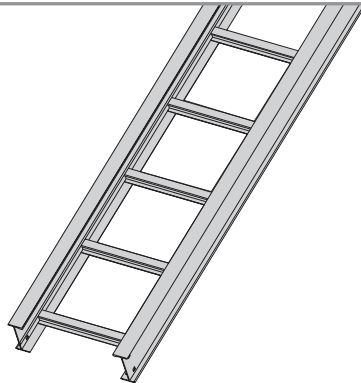

Ladder Type
(Specify Rung Spacing)

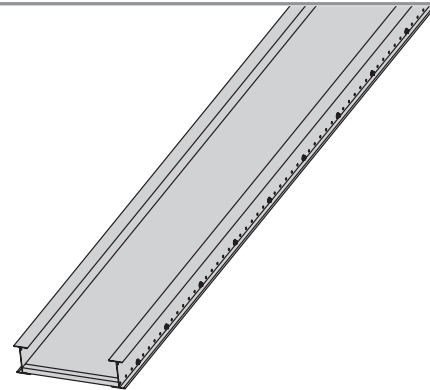

Solid Bottom

● Green = Fastest shipped items ● Black = Normal lead-time items ● Red = Normally long lead-time items

All dimensions in parentheses are millimeters unless otherwise specified.

3" NEMA VE 1 Loading Depth 4" Side Rail Height

Values are based on simple beam tests per NEMA VE 1 on 36" wide cable tray with rungs spaced on 12" centers. Cable trays will support without collapse a 200 lb. (90.7 kg) concentrated load over and above published loads. Published load safety factor is 1.5. To convert 1.5 safety factor to 2.0, multiply the published load by 0.75. To obtain mid-span deflection, multiply a load by the deflection multiplier. Cable tray must be supported on spans shorter than or equal to the length of the cable tray being installed.

Individual rungs will support without collapse a 200 lb. (90.7 kg) concentrated load applied at the mid-span of the rung, over and above the NEMA rated cable load with a 1.5 safety factor for highlighted NEMA spans and loads.

B-Line Series	Side Rail Dimensions	NEMA, CSA & UL Classifications	Span ft	Load lbs/ft	Deflection Multiplier	Design Factors for Two Rails	Span meters	Load kg/m	Deflection Multiplier	Design Factors for Two Rails
24		NEMA: 16A, 12C CSA: 277 kg/m 3.0m D-3m UL Cross-Sectional Area: 1.00 in ²	6	487*	0.001	Area = 1.05 in ² Sx = 1.34 in ³ Ix = 2.85 in ⁴	1.8	725*	0.017	Area = 6.77 cm ² Sx = 21.96 cm ³ Ix = 118.63 cm ⁴
			8	284	0.003		2.4	422	0.055	
			10	181	0.008		3.0	270	0.136	
			12	126	0.016		3.7	187	0.279	
			14	93	0.030		4.3	138	0.618	
			16	71	0.052		4.9	105	0.883	

When trays are used in continuous spans, the deflection of the tray is reduced by as much as 50%. Design factors: Ix = Moment of Inertia, Sx = Section Modulus.

* When using 18" rung spacing, load capacity is limited to 394 lbs/ft (586.27 kg/m) for 30" tray width and 325 lbs/ft (483.6 kg/m) for 36" tray width.

B-Line Series	Side Rail Dimensions	NEMA, CSA & UL Classifications	Span ft	Load lbs/ft	Deflection Multiplier	Design Factors for Two Rails	Span meters	Load kg/m	Deflection Multiplier	Design Factors for Two Rails
H24		NEMA: 20A CSA: 84 kg/m 6.1m D-6m UL Cross-Sectional Area: 1.00 in ²	10	225	0.006	Area = 1.32 in ² Sx = 1.57 in ³ Ix = 3.69 in ⁴	3.0	330	0.106	Area = 8.52 cm ² Sx = 25.73 cm ³ Ix = 153.59 cm ⁴
			12	156	0.013		3.7	226	0.222	
			14	115	0.023		4.3	171	0.400	
			16	88	0.040		4.9	129	0.693	
			18	70	0.064		5.5	103	1.093	
			20	56	0.098		6.1	83	1.682	

When trays are used in continuous spans, the deflection of the tray is reduced by as much as 50%. Design factors: Ix = Moment of Inertia, Sx = Section Modulus.

B-Line Series	Side Rail Dimensions	NEMA, CSA & UL Classifications	Span ft	Load lbs/ft	Deflection Multiplier	Design Factors for Two Rails	Span meters	Load kg/m	Deflection Multiplier	Design Factors for Two Rails
34		NEMA: 20B, 16C CSA: 112 kg/m 6.0m E-6m UL Cross-Sectional Area: 1.50 in ²	10	320	0.005	Area = 1.82 in ² Sx = 2.10 in ³ Ix = 4.98 in ⁴	3.0	476	0.077	Area = 11.74 cm ² Sx = 34.41 cm ³ Ix = 207.28 cm ⁴
			12	222	0.009		3.7	331	0.160	
			14	163	0.017		4.3	243	0.296	
			16	125	0.030		4.9	186	0.505	
			18	99	0.047		5.5	147	0.810	
			20	80	0.072		6.1	119	1.234	

When trays are used in continuous spans, the deflection of the tray is reduced by as much as 50%. Design factors: Ix = Moment of Inertia, Sx = Section Modulus.

All dimensions in parentheses are millimeters unless otherwise specified.

4" NEMA VE 1 Loading Depth 5" Side Rail Height

Straight Section Part Numbering

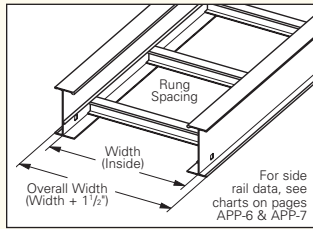
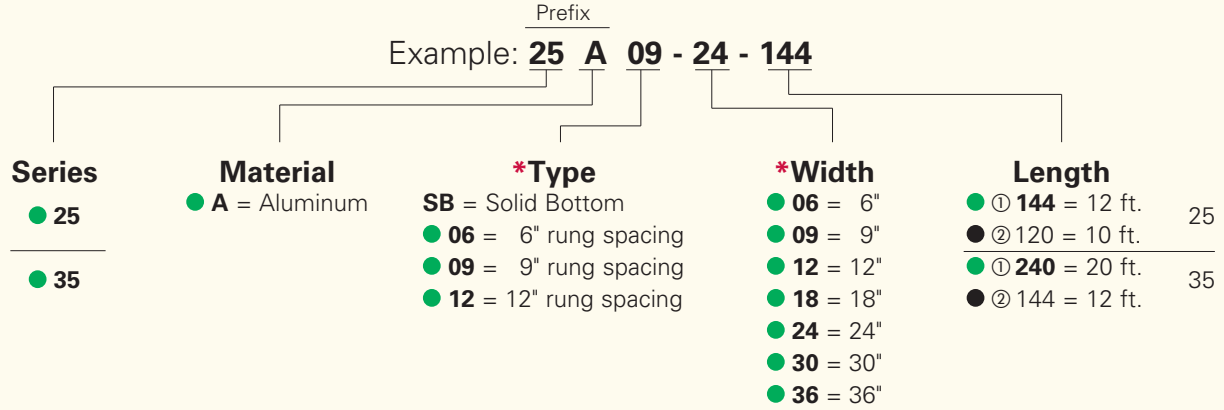

① Primary Length.
② Secondary Length.
See page C-23 for explanation of lengths.

See page APP-1 for additional rung options. *Special sizes available.

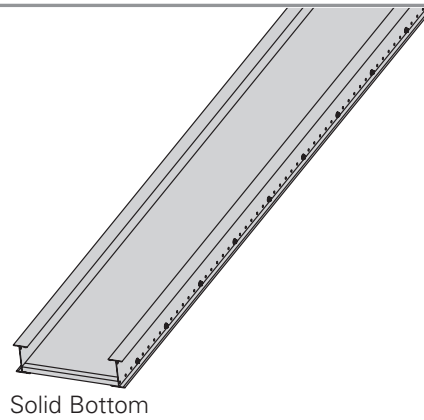
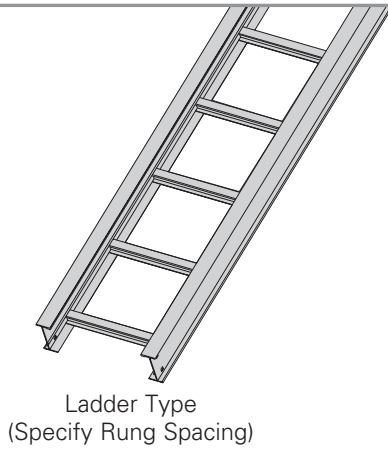

● Green = Fastest shipped items ● Black = Normal lead-time items ● Red = Normally long lead-time items

All dimensions in parentheses are millimeters unless otherwise specified.

4" NEMA VE 1 Loading Depth 5" Side Rail Height

Values are based on simple beam tests per NEMA VE 1 on 36" wide cable tray with rungs spaced on 12" centers. Cable trays will support without collapse a 200 lb. (90.7 kg) concentrated load over and above published loads. Published load safety factor is 1.5. To convert 1.5 safety factor to 2.0, multiply published load by 0.75. To obtain mid-span deflection, multiply a load by the deflection multiplier. Cable tray must be supported on spans shorter than or equal to the length of the cable tray being installed.

Individual rungs will support without collapse a 200 lb. (90.7 kg) concentrated load applied at the mid-span of the rung, over and above the NEMA rated cable load with a 1.5 safety factor for highlighted NEMA spans and loads.

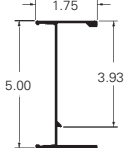
B-Line Series	Side Rail Dimensions	NEMA, CSA & UL Classifications	Span ft	Load lbs/ft	Deflection Multiplier	Design Factors for Two Rails	Span meters	Load kg/m	Deflection Multiplier	Design Factors for Two Rails
25		NEMA: 20A, 12C CSA: 67 kg/m 6.0m D-6m UL Cross-Sectional Area: 1.00 in ²	10	200	0.0049	Area = 1.24 in ² Sx = 1.80 in ³ Ix = 4.62 in ⁴	3.0	298	0.083	Area = 8.00 cm ² Sx = 29.50 cm ³ Ix = 192.30 cm ⁴
			12	139	0.010		3.7	207	0.172	
			14	102	0.019		4.3	152	0.319	
			16	78	0.032		4.9	116	0.545	
			18	62	0.051		5.5	92	0.873	
			20	50	0.078		6.1	74	1.330	

When trays are used in continuous spans, the deflection of the tray is reduced by as much as 50%. Design factors: Ix = Moment of Inertia, Sx = Section Modulus.

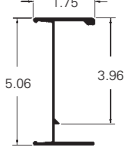
B-Line Series	Side Rail Dimensions	NEMA, CSA & UL Classifications	Span ft	Load lbs/ft	Deflection Multiplier	Design Factors for Two Rails	Span meters	Load kg/m	Deflection Multiplier	Design Factors for Two Rails
35		NEMA: 20B, 16C CSA: 112 kg/m 6.0m E-6m UL Cross-Sectional Area: 1.50 in ²	10	310	0.0036	Area = 1.67 in ² Sx = 2.35 in ³ Ix = 6.37 in ⁴	3.0	461	0.060	Area = 10.77 cm ² Sx = 38.51 cm ³ Ix = 265.14 cm ⁴
			12	215	0.0073		3.7	320	0.125	
			14	158	0.014		4.3	235	0.232	
			16	121	0.023		4.9	180	0.395	
			18	96	0.037		5.5	142	0.633	
			20	77	0.057		6.1	115	0.965	

When trays are used in continuous spans, the deflection of the tray is reduced by as much as 50%. Design factors: Ix = Moment of Inertia, Sx = Section Modulus.

All dimensions in parentheses are millimeters unless otherwise specified.

5" NEMA VE 1 Loading Depth
6" Side Rail Height

Straight Section Part Numbering

Prefix
Example: **26 A 09 - 24 - 144**

Series

● 26

● 36

● 46

● H46

● 56

Material

● A = Aluminum

***Type**

SB = Solid Bottom

● 06 = 6" rung spacing

● 09 = 9" rung spacing

● 12 = 12" rung spacing

***Width**

● 06 = 6"

● 09 = 9"

● 12 = 12"

● 18 = 18"

● 24 = 24"

● 30 = 30"

● 36 = 36"

42 = 42"†

48 = 48"†

Length

● ① 144 = 12 ft. 26

● ② 120 = 10 ft.

● ① 240 = 20 ft. 36

● ② 144 = 12 ft.

● ① 240 = 20 ft. 46

● ② 288 = 24 ft.

● ① 240 = 20 ft. H46

● ① 300 = 25 ft.

● ② 240 = 20 ft. 57

● ② 288 = 24 ft.

● ① 300 = 25 ft.

● ② 360 = 30 ft.

† For 56A only

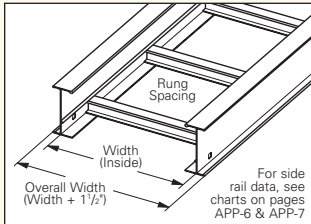

① Primary Length.
② Secondary Length.

See page C-23 for explanation of lengths.

See page APP-1 for additional rung options. *Special sizes available.

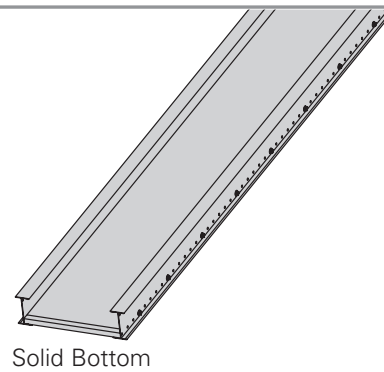
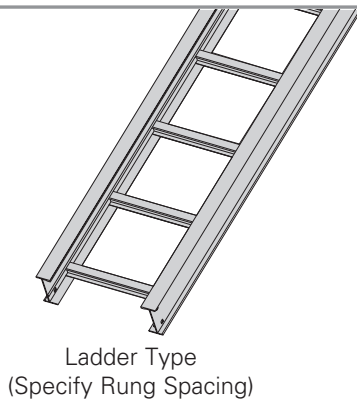

● Green = Fastest shipped items ● Black = Normal lead-time items ● Red = Normally long lead-time items

All dimensions in parentheses are millimeters unless otherwise specified.

5" NEMA VE 1 Loading Depth 6" Side Rail Height

Values are based on simple beam tests per NEMA VE 1 on 36" wide cable tray with rungs spaced on 12" centers. Cable trays will support, without collapse, a 200 lb. (90.7 kg) concentrated load over and above published loads. Published load safety factor is 1.5. To convert 1.5 safety factor to 2.0, multiply the published load by 0.75. To obtain mid-span deflection, multiply a load by the deflection multiplier. Cable tray must be supported on spans shorter than or equal to the length of the cable tray being installed.

Individual rungs will support without collapse a 200 lb. (90.7 kg) concentrated load applied at the mid-span of the rung, over and above the NEMA rated cable load with a 1.5 safety factor for highlighted NEMA spans and loads.

B-Line Series	Side Rail Dimensions	NEMA, CSA & UL Classifications	Span ft	Load lbs/ft	Deflection Multiplier	Design Factors for Two Rails	Span meters	Load kg/m	Deflection Multiplier	Design Factors for Two Rails
26		NEMA: 20A, 16B CSA: 67 kg/m 6.0m D-6m UL Cross-Sectional Area: 1.00 in ²	10	204	0.0028	Area = 1.41 in ² Sx = 2.53 in ³ Ix = 7.915 in ⁴	3.0	304	0.049	Area = 9.10 cm ² Sx = 41.46 cm ³ Ix = 329.45 cm ⁴
			12	142	0.006		3.7	211	0.101	
			14	104	0.011		4.3	155	0.186	
			16	80	0.019		4.9	119	0.318	
			18	63	0.030		5.5	94	0.509	
			20	51	0.045		6.1	76	0.776	

When trays are used in continuous spans, the deflection of the tray is reduced by as much as 50%. Design factors: Ix = Moment of Inertia, Sx = Section Modulus.

B-Line Series	Side Rail Dimensions	NEMA, CSA & UL Classifications	Span ft	Load lbs/ft	Deflection Multiplier	Design Factors for Two Rails	Span meters	Load kg/m	Deflection Multiplier	Design Factors for Two Rails
36		NEMA: 20B, 16C CSA: 112 kg/m 6.0m E-6m UL Cross-Sectional Area: 1.50 in ²	12	233	0.0043	Area = 1.81 in ² Sx = 3.36 in ³ Ix = 10.85 in ⁴	3.7	347	0.073	Area = 11.68 cm ² Sx = 55.06 cm ³ Ix = 451.61 cm ⁴
			14	171	0.008		4.3	255	0.136	
			16	131	0.014		4.9	195	0.232	
			18	104	0.022		5.5	154	0.372	
			20	84	0.033		6.1	125	0.566	
			22	69	0.049		6.7	103	0.829	

When trays are used in continuous spans, the deflection of the tray is reduced by as much as 50%. Design factors: Ix = Moment of Inertia, Sx = Section Modulus.

B-Line Series	Side Rail Dimensions	NEMA, CSA & UL Classifications	Span ft	Load lbs/ft	Deflection Multiplier	Design Factors for Two Rails	Span meters	Load kg/m	Deflection Multiplier	Design Factors for Two Rails
46		NEMA: 20C CSA: 168 kg/m 6.1m E-6m UL Cross-Sectional Area: 1.50 in ²	14	210	0.0071	Area = 2.06 in ² Sx = 3.59 in ³ Ix = 12.18 in ⁴	4.3	313	0.121	Area = 13.29 cm ² Sx = 58.83 cm ³ Ix = 506.97 cm ⁴
			16	161	0.012		4.9	239	0.207	
			18	127	0.019		5.5	189	0.331	
			20	103	0.030		6.1	153	0.505	
			22	85	0.043		6.7	127	0.739	
			24	72	0.061		7.3	106	1.046	

When trays are used in continuous spans, the deflection of the tray is reduced by as much as 50%. Design factors: Ix = Moment of Inertia, Sx = Section Modulus.

B-Line Series	Side Rail Dimensions	NEMA, CSA & UL Classifications	Span ft	Load lbs/ft	Deflection Multiplier	Design Factors for Two Rails	Span meters	Load kg/m	Deflection Multiplier	Design Factors for Two Rails
H46		NEMA: 20C+ CSA: 131 kg/m 7.6m E-6m UL Cross-Sectional Area: 2.00 in ²	16	261	0.0085	Area = 2.95 in ² Sx = 5.33 in ³ Ix = 17.30 in ⁴	4.9	388	0.145	Area = 19.03 cm ² Sx = 87.34 cm ³ Ix = 720.08 cm ⁴
			18	206	0.014		5.5	307	0.233	
			20	167	0.021		6.1	248	0.355	
			22	138	0.030		6.7	205	0.520	
			24	116	0.043		7.3	173	0.737	
			25	88	0.051		7.6	131	0.867	

When trays are used in continuous spans, the deflection of the tray is reduced by as much as 50%. Design factors: Ix = Moment of Inertia, Sx = Section Modulus.

B-Line Series	Side Rail Dimensions	NEMA, CSA & UL Classifications	Span ft	Load lbs/ft	Deflection Multiplier	Design Factors for Two Rails	Span meters	Load kg/m	Deflection Multiplier	Design Factors for Two Rails
56		NEMA: 20C+ CSA: 112 kg/m 9.1m E-6m UL Cross-Sectional Area: 2.00 in ²	20	169	0.016	Area = 3.63 in ² Sx = 6.12 in ³ Ix = 22.63 in ⁴	6.1	251	0.272	Area = 23.42 cm ² Sx = 100.29 cm ³ Ix = 941.86 cm ⁴
			22	139	0.023		6.7	208	0.398	
			24	117	0.033		7.3	174	0.563	
			26	100	0.045		7.9	149	0.776	
			28	86	0.061		8.5	128	1.043	
			30	75	0.081		9.1	112	1.375	

When trays are used in continuous spans, the deflection of the tray is reduced by as much as 50%. Design factors: Ix = Moment of Inertia, Sx = Section Modulus.

All dimensions in parentheses are millimeters unless otherwise specified.

**6" NEMA VE 1 Loading Depth
7" Side Rail Height**

Straight Section Part Numbering

Example: ^{Prefix} **37 A 09 - 24 - 144**

Series

- 27
- 37
- 47
- H47†
- 57

Material

- A = Aluminum

***Type**

- SB = Solid Bottom
- 06 = 6" rung spacing
- 09 = 9" rung spacing
- 12 = 12" rung spacing

***Width**

- 06 = 6"
- 09 = 9"
- 12 = 12"
- 18 = 18"
- 24 = 24"
- 30 = 30"
- 36 = 36"

Length

- ① 144 = 12 ft. 27
- ② 120 = 10 ft.
- ① 240 = 20 ft. 37
- ② 144 = 12 ft.
- ① 240 = 20 ft. 47
- ② 288 = 24 ft.
- ① 240 = 20 ft. H47
- ② 300 = 25 ft.
- ① 360 = 30 ft. 57
- ② 300 = 25 ft.

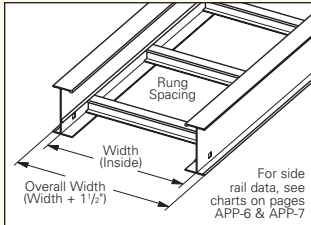

† H47A & 57A only available in ladder type 9" and 12" rung spacing. See page APP-2.

- ① Primary Length.
- ② Secondary Length.

See page C-23 for explanation of lengths.

See page APP-1 for additional rung options. *Special sizes available.

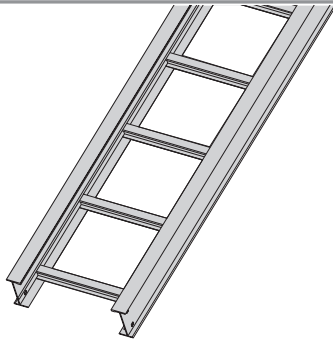

Ladder Type
(Specify Rung Spacing)

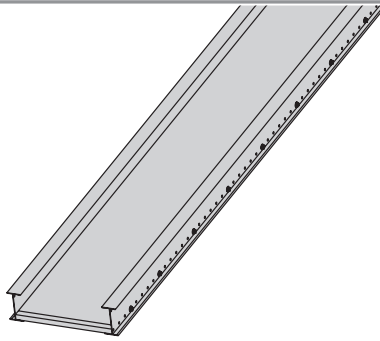

Solid Bottom



57A available in
(9" & 12" rung spacing in
12" to 36" widths)

● Green = Fastest shipped items ● Black = Normal lead-time items ● Red = Normally long lead-time items

All dimensions in parentheses are millimeters unless otherwise specified.

6" NEMA VE 1 Loading Depth 7" Side Rail Height

Values are based on simple beam tests per NEMA VE 1 on 36" wide cable tray with rungs spaced on 12" centers. Cable trays will support without collapse a 200 lb. (90.7 kg) concentrated load over and above published loads. Published load safety factor is 1.5. To convert 1.5 safety factor to 2.0, multiply the published load by 0.75. To obtain mid-span deflection, multiply a load by the deflection multiplier. Cable tray must be supported on spans shorter than or equal to the length of the cable tray being installed.

Individual rungs will support without collapse a 200 lb. (90.7 kg) concentrated load applied at the mid-span of the rung, over and above the NEMA rated cable load with a 1.5 safety factor for highlighted NEMA spans and loads.

B-Line Series	Side Rail Dimensions	NEMA, CSA & UL Classifications	Span ft	Load lbs/ft	Deflection Multiplier	Design Factors for Two Rails	Span meters	Load kg/m	Deflection Multiplier	Design Factors for Two Rails
27		NEMA: 12C CSA: 68 kg/m 6.0m D-6m UL Cross-Sectional Area: 1.50 in ²	10	177	0.006	Area = 1.63 in ² Sx = 2.93 in ³ Ix = 11.28 in ⁴	3.0	269	0.033	Area = 10.52 cm ² Sx = 48.01 cm ³ Ix = 469.51 cm ⁴
			12	123	0.013		3.7	177	0.073	
			14	90	0.023		4.3	134	0.131	
			16	69	0.040		4.9	101	0.227	
			18	54	0.064		5.5	81	0.357	
			20	44	0.098		6.1	67	0.534	
37		NEMA: 20B, 16C CSA: 101 kg/m 6.1m D-6m UL Cross-Sectional Area: 1.50 in ²	12	222	0.0035	Area = 1.81 in ² Sx = 3.77 in ³ Ix = 13.50 in ⁴	3.7	331	0.059	Area = 11.68 cm ² Sx = 61.78 cm ³ Ix = 561.91 cm ⁴
			14	163	0.0064		4.3	243	0.109	
			16	125	0.011		4.9	186	0.186	
			18	99	0.017		5.5	147	0.299	
			20	80	0.027		6.1	119	0.455	
			22	66	0.039		6.7	98	0.666	
47		NEMA: 20C CSA: 142 kg/m 6.1m E-6m UL Cross-Sectional Area: 2.00 in ²	14	204	0.0048	Area = 2.38 in ² Sx = 4.94 in ³ Ix = 17.88 in ⁴	4.3	305	0.083	Area = 15.35 cm ² Sx = 80.95 cm ³ Ix = 744.22 cm ⁴
			16	156	0.0082		4.9	233	0.141	
			18	123	0.0132		5.5	184	0.225	
			20	100	0.0201		6.1	149	0.344	
			22	83	0.0295		6.7	123	0.503	
			24	69	0.0418		7.3	103	0.713	
H47		NEMA: 20C+ CSA: 241 kg/m 6.1m E-6m UL Cross-Sectional Area: 2.00 in ²	16	233	0.0064	Area = 3.04 in ² Sx = 6.10 in ³ Ix = 22.91 in ⁴	4.9	346	0.110	Area = 19.61 cm ² Sx = 99.96 cm ³ Ix = 953.59 cm ⁴
			18	184	0.010		5.4	274	0.176	
			20	149	0.016		6.1	222	0.268	
			22	123	0.023		6.7	183	0.393	
			24	103	0.033		7.3	154	0.556	
			25	95	0.038		7.6	142	0.655	
57		NEMA: 20C+ CSA: 151 kg/m 9.1m E-6m UL Cross-Sectional Area: 2.00 in ²	20	232	0.011	Area = 4.22 in ² Sx = 7.73 in ³ Ix = 32.86 in ⁴	6.1	345	0.187	Area = 27.73 cm ² Sx = 126.67 cm ³ Ix = 1367.74 cm ⁴
			22	192	0.016		6.7	285	0.274	
			24	161	0.023		7.3	240	0.388	
			26	136	0.031		7.9	202	0.534	
			28	117	0.042		8.5	174	0.718	
			30	102	0.055		9.1	152	0.947	

When trays are used in continuous spans, the deflection of the tray is reduced by as much as 50%. Design factors: Ix = Moment of Inertia, Sx = Section Modulus.

All dimensions in parentheses are millimeters unless otherwise specified.

6" NEMA VE 1 Loading Depth 8" Side Rail Height

Straight Section Part Numbering

Prefix
Example: **S8 A 09 - 24 - 144**

Series	Material	*Type	*Width	Length
● S8	● A = Aluminum	Ladder-	● 12 = 12"	● 480 = 40 ft.
		● 09 = 9" rung spacing	● 18 = 18"	● ① 360 = 30 ft.
		● 12 = 12" rung spacing	● 24 = 24"	● ② 300 = 25 ft.
			● 30 = 30"	
			● 36 = 36"	

① Primary Length.
② Secondary Length.

See page C-23 for explanation of lengths.

See page APP-1 for additional rung options. *Special sizes available.

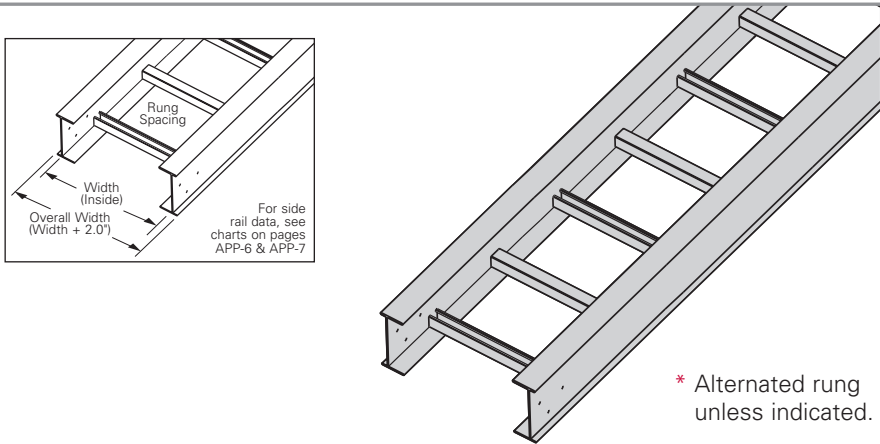

Values are based on simple beam tests per NEMA VE 1 on 36" wide cable tray with rungs spaced on 12" centers. Cable trays will support without collapse a 200 lb. (90.7 kg) concentrated load over and above published loads. Published load safety factor is 1.5. To convert 1.5 safety factor to 2.0, multiply the published load by 0.75. To obtain mid-span deflection, multiply a load by the deflection multiplier. Cable tray must be supported on spans shorter than or equal to the length of the cable tray being installed.

Individual rungs will support without collapse a 200 lb. (90.7 kg) concentrated load applied at the mid-span of the rung, over and above the NEMA rated cable load with a 1.5 safety factor for highlighted NEMA spans and loads.

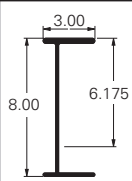
B-Line Series	Side Rail Dimensions	NEMA, CSA & UL Classifications	Span ft	Load lbs/ft	Deflection Multiplier	Design Factors for Two Rails	Span meters	Load kg/m	Deflection Multiplier	Design Factors for Two Rails
S8A		NEMA: 20C+ CSA: 240 kg/m 9.1m UL Cross-Sectional Area: 2.00 in ²	20	363	0.007	Area=5.50 in ² Sx=15.39 in ³ Ix=55.35 in ⁴	6.1	540	0.111	Area=35.48 cm ² Sx=252.20 cm ³ Ix=2303.84 cm ⁴
			22	300	0.010		6.7	446	0.163	
			24	252	0.013		7.3	375	0.230	
			26	215	0.019		7.9	320	0.317	
			28	185	0.025		8.5	276	0.427	
			30	161	0.033		9.1	240	0.562	
40	101	0.146	12.2	151	2.488					

● Green = Fastest shipped items ● Black = Normal lead-time items ● Red = Normally long lead-time items

All dimensions in parentheses are millimeters unless otherwise specified.

The following is a list of accessories and fittings that can be provided with S8A tray. For more information on these items, contact our Engineering Department.

● Fittings

Horizontal Bends

- 30° Bends with 24", 36", or 48" radius
- 45° Bends with 24", 36", or 48" radius
- 60° Bends with 24", 36", or 48" radius
- 90° Bends with 24", 36", or 48" radius

Horizontal Tees & Crosses

With 24", 36", or 48" radius

Vertical Outside Bends

- 30° Bends with 24", 36", or 48" radius
- 45° Bends with 24", 36", or 48" radius
- 60° Bends with 24", 36", or 48" radius
- 90° Bends with 24", 36", or 48" radius

Vertical Inside Bends

- 30° Bends with 24", 36", or 48" radius
- 45° Bends with 24", 36", or 48" radius
- 60° Bends with 24", 36", or 48" radius
- 90° Bends with 24", 36", or 48" radius

Reducing Fittings

● Accessories - (standard hardware is stainless steel Type 316)

Splice Plate - 9A-1008

Expansion Splice Plate - 9A-1018

Horizontal Adjustable Splice Plate - 9A-1038

Vertical Adjustable Splice Plate - 9A-1028

Hold Down Clamps - 9ZN-1281, 9G-1281, 9A-1281

Guides - S9ZN-1202, S9G-1202

Step Down Splice Plate -

9A-1048 = 8" to 4"

9A-1051 = 8" to 5"

9A-1050 = 8" to 6"

9A-1078 = 8" to 7"

Other Accessories Include:

Offset Splice Plates

Blind Ends

Covers - Standard aluminum cover number with S in front (Example: S807A40)

● Green = Fastest shipped items ● Black = Normal lead-time items ● Red = Normally long lead-time items

All dimensions in parentheses are millimeters unless otherwise specified.

Series 2, 3, 4, & 5 Aluminum - Accessories

Wedge Lock Splice Plates

- Furnished in pairs with $\frac{3}{8}$ " hardware.
- Standard 4-hole pattern.
- Furnished in pairs, with hardware.
- One pair including hardware provided with each section. (Expansion splice quantity subtracted)
- Boxed in pairs with hardware.
- For field installation drill $\frac{13}{32}$ " hole.

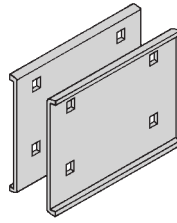

Catalog No.	Height in. mm
● 9A-1004	4 (101)
● 9A-1005	5 (127)
● 9A-1006	6 (152)
● 9A-1007	7 (178)

H46A, H47A, 56A and 57A Mid-Span Splice

- Furnished in pairs with $\frac{3}{8}$ " hardware.
- Standard for H46A, H47A, 56A and 57A straight sections.
- Six bolt design $\frac{1}{2}$ " Stainless Steel Type 316 hardware standard.
- Available on ladder bottoms only. 09 and 12" rung spacing.
- Furnished in pairs with hardware.

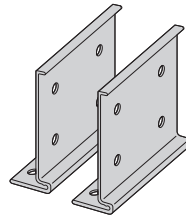

Catalog No.	Tray Series
● 9A-6006	H46A
● 9A-6007	H47A, 57A

Expansion Splice Plates

- Expansion plates allow for one inch expansion or contraction of the cable tray, or where expansion joints occur in the supporting structure.
- Furnished in pairs with hardware.
- **Bonding Jumpers are required on each siderail. Order Separately.**

For heavy duty expansion splice plates see page APP-3.

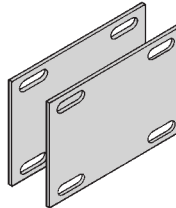

Catalog No.	Height in. mm
● 9A-1014	4 (101)
● 9A-1015	5 (127)
● 9A-1016	6 (152)
● 9A-1017	7 (178)

Requires supports within 24" on both sides, per NEMA VE 2.

Universal Splice Plates

- Furnished in pairs with $\frac{3}{8}$ " hardware.
- UL Classified.

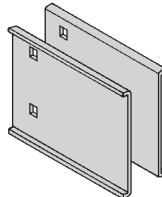

Catalog No.	Height in. mm
● 9A-1004- $\frac{1}{2}$	4 (101)
● 9A-1005- $\frac{1}{2}$	5 (127)
● 9A-1006- $\frac{1}{2}$	6 (152)
● 9A-1007- $\frac{1}{2}$	7 (178)

Step Down Splice Plates

- These splice plates are offered for connecting cable tray sections having side rails of different heights.
- Furnished in pairs with hardware.

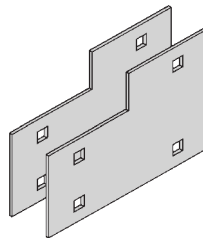

Catalog No.	Height in. mm
● 9A-1045	5 to 4 (127 to 101)
● 9A-1046	6 to 4 (152 to 101)
● 9A-1060	6 to 5 (152 to 127)
● 9A-1047	7 to 4 (178 to 101)
● 9A-1061	7 to 5 (178 to 127)
● 9A-1062	7 to 6 (178 to 152)

Vertical Adjustable Splice Plates

- These plates provide for changes in elevation that do not conform to standard vertical fittings.
- Furnished in pairs with hardware.
- Bonding Jumpers not required.

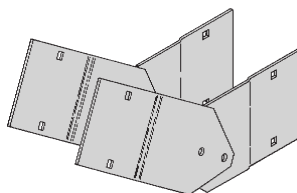

Catalog No.	Height in. mm
● 9A-1024	4 (101)
● 9A-1025	5 (127)
● 9A-1026	6 (152)
● 9A-1027	7 (178)

● Green = Fastest shipped items ● Black = Normal lead-time items ● Red = Normally long lead-time items

All dimensions in parentheses are millimeters unless otherwise specified.

Horizontal Adjustable Splice Plates

- Offered to adjust a cable tray run for changes in direction in a horizontal plane that do not conform to standard horizontal fittings.
- Furnished in pairs with hardware.
- Bonding jumpers **not** required.
- (X) Insert 4, 5, 6 or 7 for side rail height.

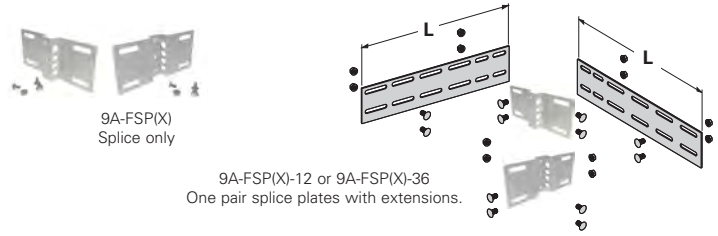

Catalog No.	Width (in.)	Height (in.)	Depth (in.)	Weight (lbs.)
9A-FSP4	8.575	3.891	.820	0.253
9A-FSP5	8.575	4.781	.820	0.312
9A-FSP6	8.575	5.891	.820	0.386
9A-FSP7	8.575	6.891	.820	0.456

Catalog No.	Cable Tray End Cut	Thru Tray Width in. mm	'L' in. mm
● 9A-FSP(X)	Mitered	36 (914)	N/A N/A
● 9A-FSP(X)-12	Not mitered	12 (305)	16 (406)
● 9A-FSP(X)-36	Not mitered	36 (914)	41 (1041)

Requires supports within 24" on both sides, per NEMA VE 2.

Branch Pivot Connectors

- Branch from existing cable tray runs at any point.
- Pivot to any required angle.
- UL Classified for grounding (bonding jumpers not required).
- Furnished in pairs with hardware.

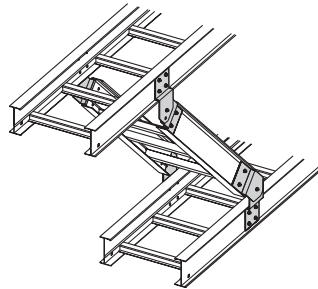

Catalog No.	Height in. mm
● 9A-2044	4 (101)
● 9A-2045	5 (127)
● 9A-2046	6 (152)
● 9A-2047	7 (178)

Offset Reducing Splice Plate

- This plate is used for joining cable trays having different widths. When used in pairs they form a straight reduction; when used singly with a standard splice plate, they form an offset reduction.
- Furnished as one plate with hardware.
- (‡) Insert reduction

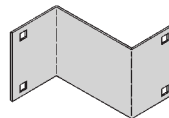

Catalog No.	Height in. mm
● 9A-1064-‡	4 (101)
● 9A-1065-‡	5 (127)
● 9A-1066-‡	6 (152)
● 9A-1067-‡	7 (178)

Tray to Box Splice Plates

- Used to attach the end of a cable tray run to a distribution box or control panel.
- Furnished in pairs with hardware

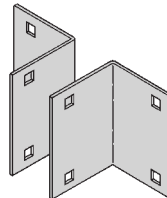

Catalog No.	Height in. mm
● 9A-1054	4 (101)
● 9A-1055	5 (127)
● 9A-1056	6 (152)
● 9A-1057	7 (178)

Frame Type Box Connector

- Designed to attach the end of a cable tray run to a distribution cabinet or control center to help reinforce the box at the point of entry.
- Furnished with tray connection hardware.

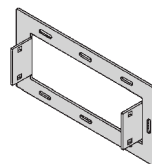

Catalog No.	Height in. mm
● 9A-1074-‡	4 (101)
● 9A-1075-‡	5 (127)
● 9A-1076-‡	6 (152)
● 9A-1077-‡	7 (178)

Blind End

- This plate forms a closure for a dead end cable tray.
- Furnished as one plate with hardware.
- (‡) Insert tray width

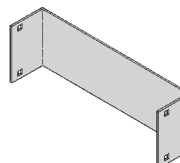

Catalog No.	Height in. mm
● 9A-1084-‡	4 (101)
● 9A-1085-‡	5 (127)
● 9A-1086-‡	6 (152)
● 9A-1087-‡	7 (178)

● Green = Fastest shipped items ● Black = Normal lead-time items ● Red = Normally long lead-time items

All dimensions in parentheses are millimeters unless otherwise specified.

Series 2, 3, 4, & 5 Aluminum - Accessories

Standard Tray Hardware (for field installation drill $13/32$ " hole)

- Finish: Zinc Plated ASTM B633 SC1

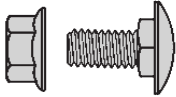

Catalog No.	Description
● SNCB $3/8$" x $3/4$" ZN	Square Neck Carriage Bolt ASTM A307 Grade A
● SFHN $3/8$"-16 ZN	Serrated Flange Hex Nut ASTM A563 Grade A

Optional Tray Hardware (for field installation drill $13/32$ " hole)

- To order 316 stainless steel hardware add SS6 suffix to catalog number - Example: 9A1004SS6

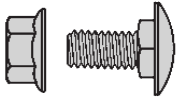

Catalog No.	Description
● SNCB $3/8$" x $3/4$" SS6	Square Neck Carriage Bolt AISI 316 Stainless Steel
● SFHN $3/8$"-16 SS6	Serrated Flange Hex Nut AISI 316 Stainless Steel

Cross Connector Bracket

- For field connecting crossing section.
- Furnished in pairs with $3/8$ " hardware.

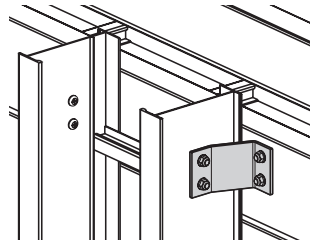
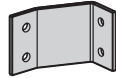

Catalog No.
● 9A-1240

Conduit to Cable Tray Adaptor

- For easy attachment of conduit terminating at a cable tray.
- Use on aluminum or steel cable trays.
- Will not fit on S8A.

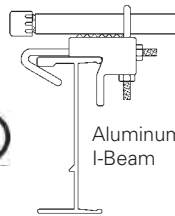
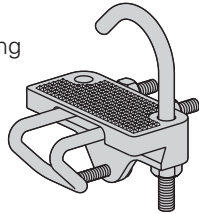

Aluminum I-Beam

Catalog No.	Conduit Size	
	in.	mm
● 9G-1158-$1/2$ & $3/4$	$1/2, 3/4$	(15, 20)
● 9G-1158-1 & $1 1/4$	1, $1 1/4$	(25, 32)
● 9G-1158-$1 1/2$ & 2	$1 1/2, 2$	(40, 50)
● 9G-1158-$2 1/2$ & 3	$2 1/2, 3$	(65, 80)
● 9G-1158-$3 1/2$ & 4	$3 1/2, 4$	(90, 100)

Conduit to Cable Tray Adaptor

- Assembly required.
- Mounting hardware included.
- Conduit clamps provided.
- (‡) = Insert conduit size ($1/2$ " thru 4").

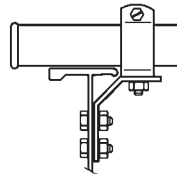

Catalog No.
● 9ZN-1150-(‡)

Conduit to Cable Tray Adaptor

- Assembly required.
- Conduit clamps included.
- Will not fit on S8A.
- (‡) = Insert conduit size ($1/2$ " thru 4").

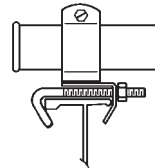
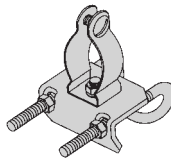

Catalog No.
● 9ZN-1155-(‡)

Cable Tie (Ladder Tray)

- Nylon ties provide easy attachment of cable to ladder rungs; maximum cable O.D. is 3" (76mm).
- Cable ties are UV resistant.

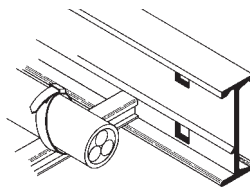

Overall Length 15" (381mm)

Catalog No.
● 99-2125-15

● Green = Fastest shipped items ● Black = Normal lead-time items ● Red = Normally long lead-time items

All dimensions in parentheses are millimeters unless otherwise specified.

Ladder Drop-Out

- Specially-designed Ladder Drop-Outs provide a rounded surface with 4" (101 mm) radius to protect cable as it exits from the cable tray, preventing damage to insulation. The drop-out will attach to any desired rung.
- (‡) Insert tray width

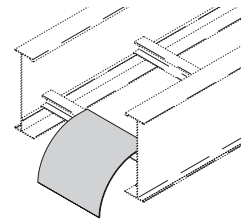
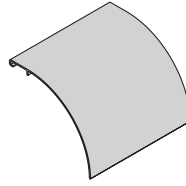

Catalog No.

● 9A-1104-(‡)

Trough Drop-Out

- This device provides a rounded surface to protect cable as it exits from the cable tray.
- Hardware is included for bottom drop-out.
- (‡) Insert tray width

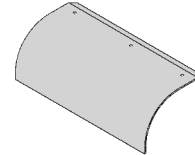

Trough-Type Drop-Out

Catalog No.

● 9A-1104T-(‡)

Barrier - Straight Section

- Length: Insert 120 for [120" - 10 ft.] (3.0 m) or 144 for [144" - 12 ft.] (3.6 m)
- Order catalog number based on loading depth.
- Furnished with four #10 x 1/2" plated self-drilling screws and a 99-9982 Barrier Strip Splice.

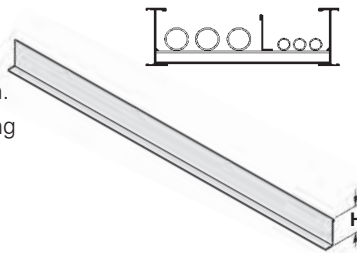

Catalog No.	Side Rail Height in. mm	Loading Depth 'H' in. mm
● 73A-Length	4 (101)	3 (76)
● 74A-Length	5 (127)	4 (101)
● 75A-Length	6 (152)	5 (127)
● 76A-Length	7 (178)	6 (152)

Barrier - Horizontal Bend

- Horizontal Bend Barriers are flexible in order to conform to any horizontal fitting radius. Can be cut to desired length.
- Standard length is 72" [6 ft.] (1.8 m) - sold individually
- Order catalog number based on loading depth.
- Furnished with three #10 x 1/2" plated self-drilling screws and a 99-9982 Barrier Strip Splice.

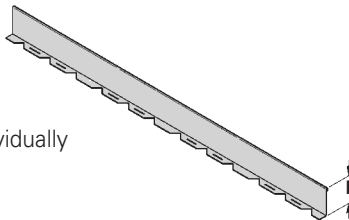

Catalog No.	Side Rail Height in. mm	Loading Depth 'H' in. mm
● 73A-90HBFL	4 (101)	3 (76)
● 74A-90HBFL	5 (127)	4 (101)
● 75A-90HBFL	6 (152)	5 (127)
● 76A-90HBFL	7 (178)	6 (152)

Barrier - Vertical Outside Bend

- Vertical Outside Bend Barriers are preformed to conform to a specific vertical outside bend fitting.
- Furnished with three #10 x 1/2" plated self-drilling screws and a 99-9982 Barrier Strip Splice.
- (*) Insert 30, 45, 60 or 90 for degrees
- (†) Insert 12, 24, 36 or 48 for radius

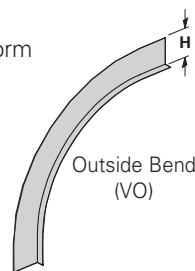

Catalog No.	Side Rail Height in. mm	Loading Depth 'H' in. mm
● 73A-(*)VO(†)	4 (101)	3 (76)
● 74A-(*)VO(†)	5 (127)	4 (101)
● 75A-(*)VO(†)	6 (152)	5 (127)
● 76A-(*)VO(†)	7 (178)	6 (152)

Barrier - Vertical Inside Bend

- Vertical Inside Bend Barriers are preformed to conform to a specific vertical inside bend fitting.
- Furnished with three #10 x 1/2" plated self-drilling screws and a 99-9982 Barrier Strip Splice.
- (*) Insert 30, 45, 60 or 90 for degrees
- (†) Insert 12, 24, 36 or 48 for radius

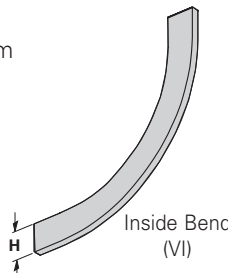

Catalog No.	Side Rail Height in. mm	Loading Depth 'H' in. mm
● 73A-(*)VI(†)	4 (101)	3 (76)
● 74A-(*)VI(†)	5 (127)	4 (101)
● 75A-(*)VI(†)	6 (152)	5 (127)
● 76A-(*)VI(†)	7 (178)	6 (152)

● Green = Fastest shipped items ● Black = Normal lead-time items ● Red = Normally long lead-time items

All dimensions in parentheses are millimeters unless otherwise specified.

Series 2, 3, 4, & 5 Aluminum - Accessories

Barrier Strip Clip

- Provides attachment to rung.
- Allows for installed barrier adjustment.
- Asymmetrical clip provides a wide range for screw location.
- Barrier strip clips not included with barriers.
(Must be ordered separately)

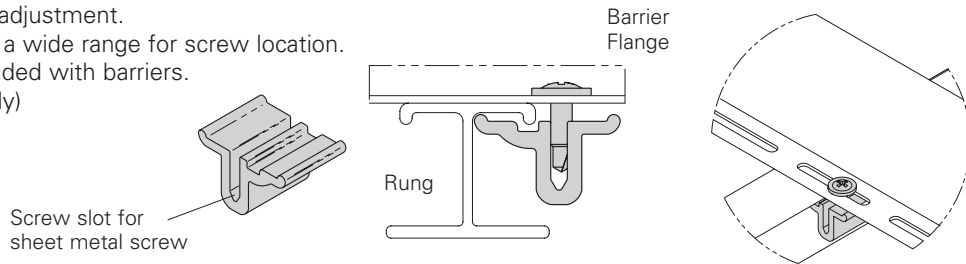

Catalog No.
● 9A-RBC

Barrier Strip Splice

- 2.85" (72.4mm) long
- Ribbed edge for increased rigidity and grip
- Comfort edge for ease of installation
- Slotted top window with center mark for accurate placement and inspection capability
- Patent pending

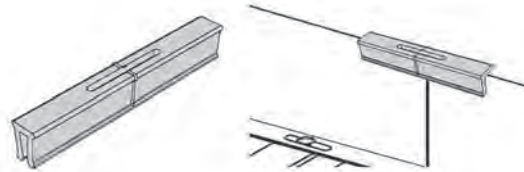

Catalog No.
● 99-9982

Bonding Jumper

Use at each expansion splice and where the cable tray is not mechanically/ electrically continuous to ground. Sold individually.

- Hardware included.
- See table 392.60(A) on page MAN-29 for amperage ratings required to match the UL cross-sectional area of the tray.
- See tray loading chart for UL cross-sectional area.
- Bonding jumper is 14 1/2" (368mm) long.

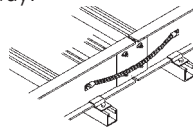

Catalog No.	Copper Wire Size	Ampacity
● 99-N1	#1	600
● 99-30	3/0	1200
● 99-40	4/0	1600
● 99-1620	250 MCM	2000

Grounding Clamp

Eaton's B-Line series cable tray is UL® classified as to its suitability as an equipment grounding conductor. If a separate conductor for additional grounding capability is desired, B-Line offers this clamp for bolting the conductor at least once to each cable tray section.

- Accepts #6 AWG to 250 MCM.

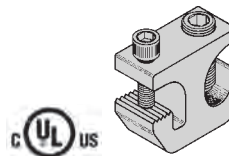

Catalog No.	Material
● 9A-2130	Tin Plated Aluminum

Ground Wire Clamp

- Mechanically attaches grounding cables to cable tray.
- Hardware included.
- (*) Insert **ZN** or **SS4**

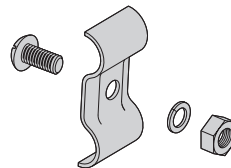

Catalog No.	Material
9(*)-2351	#1 thru 2/0
9(*)-2352	3/0 thru 250 MCM

Thread Rod (ATR) & Rod Couplings

Loading based on safety factor 5.
Standard Finish: Zinc plated

See B-Line series Strut Systems Catalog for other sizes and finishes.

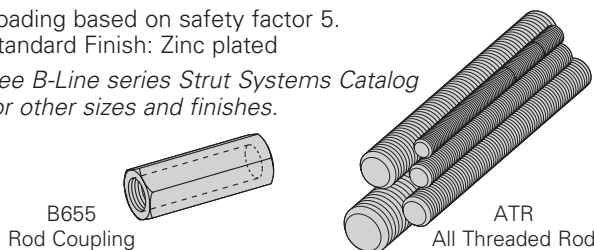

Size	Catalog No.	Available Length	Loading
All Threaded Rod			
3/8"-16	● ATR 3/8" x Length	36", 72", 120", 144"	730 lbs.
1/2"-13	● ATR 1/2" x Length	36", 72", 120", 144"	1350 lbs.
Rod Coupling			
3/8"-16	● B655-3/8"	NA	730 lbs.
1/2"-13	● B655-1/2"	NA	1350 lbs.

● Green = Fastest shipped items ● Black = Normal lead-time items ● Red = Normally long lead-time items

All dimensions in parentheses are millimeters unless otherwise specified.

Stainless Steel Cable Clamp 'P'

- Fits with series 2, 3, & 4 rungs.
- Attaches to rung at any point.
- 14 gauge Type 316 stainless steel material to minimize corrosion and induction heating.
- Plated steel and aluminum also available.

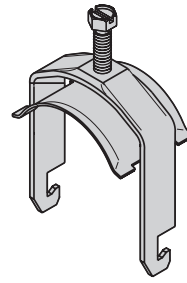
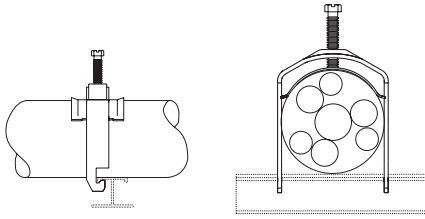

Refer to Section CF
Cable Fixing

Catalog No.	Cable Size	
	in.	mm
● BP081SS	.250 - .840	(6.4 - 21.3)
● BP110SS	.810 - 1.100	(20.6 - 28.0)
● BP135SS	.850 - 1.350	(21.6 - 34.8)
● BP175SS	1.250 - 1.750	(31.8 - 44.5)
● BP205SS	1.550 - 2.050	(39.4 - 52.1)
● BP250SS	2.000 - 2.500	(50.8 - 63.5)
● BP300SS	2.500 - 3.000	(63.5 - 76.2)
● BP325SS	2.750 - 3.250	(69.9 - 82.6)
● BP375SS	3.250 - 3.750	(82.6 - 95.3)
● BP425SS	3.750 - 4.250	(95.3 - 108.0)
● BP475SS	4.250 - 4.750	(108.0 - 120.7)

Hanger Rod Clamp

- For 1/2" ATR.
- Furnished in pairs.
- Order ATR and hex nuts separately.
- Two-piece "J"-hanger design.
- 1500 lbs./pair capacity safety factor 3.
- (*) Insert **ZN** or **G**

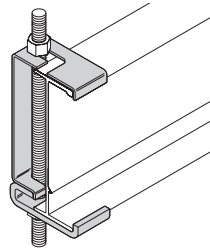

Catalog No.	Height	
	in.	mm
9(*)-5324	4	(101)
9(*)-5325	5	(127)
9(*)-5326	6	(152)
9(*)-5327	7	(178)

Cable Tray Clamp/Guide

- Features a no-twist design.
- Has four times the strength of the traditional design.
- Each side is labeled to ensure proper installation.
- Furnished in pairs, with or without hardware.
- Not recommended for vertical support.

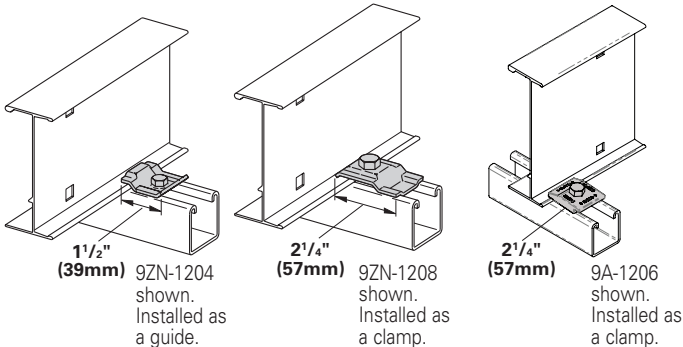

Catalog No.		Overall Length in. (mm)	Hardware Size in.	Finish
Without Hardware	With Hardware			
● 9ZN-1204	● 9ZN-1204NB	1 1/2 (38)	1/4"	G90
● 9ZN-1208	● 9ZN-1208NB	2 1/4 (57)	3/8"	G90
● 9A-1206	● 9A-1206NB	2 1/4 (57)	3/8"	Alum.
● 9A-1205	—	2 1/4 (57)	1/2"	Alum.
● 9G-1205	—	2 1/4 (57)	1/2"	HDGAF
● 9SS6-1205	—	2 1/4 (57)	1/2"	316SS
● 9ZN-1205	—	2 1/4 (57)	1/2"	G90

Note: For heavy duty or vertical applications see 9(*)-1241 or 9(*)-1242 page I-22

Isolator Pad

- Use as a friction reducer and/or as a dissimilar metal isolator barrier.
- UV resistant HDPE.
- Temperature range: -100 to 160° F.
- Designed to use with 9(*)-1205 or 9(*)-1208 clamp/guide.
- Color - White.

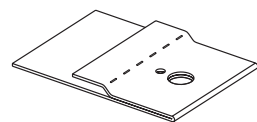

Isolation pad shown as when used with a guide.

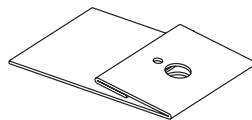

Isolation pad shown with top flange doubled under for clamp application.

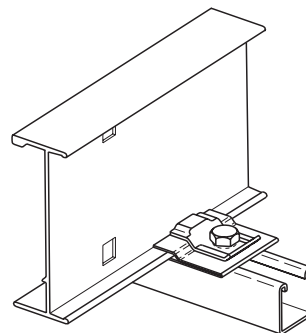

Catalog No.

● **99-PE34**

● Green = Fastest shipped items ● Black = Normal lead-time items ● Red = Normally long lead-time items

All dimensions in parentheses are millimeters unless otherwise specified.

Series 2, 3, 4, & 5 Aluminum - Accessories

Cable Tray Clamp

- Hold-down clamps for single or double cable tray runs.
- No drilling of support I-beam or channel is required.
- Sold in pieces - two clamps are required per tray.
- Maximum beam flange thickness 1¹/₈" (28.58 mm).

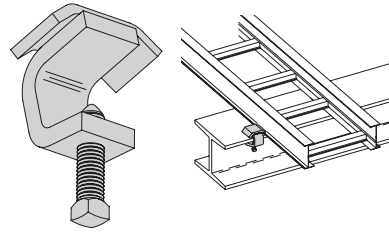

Catalog No.	Finish
● 9ZN-1249HD	Znplt
● 9G-1249HD	HDGAF

Cable Tray Guide

- Expansion guide for single or double cable tray runs.
- Guide allows for longitudinal movement of the cable tray.
- No field drilling of support I-beam or channel is required.
- Guides are required on both sides of cable tray to prevent lateral movement - can be placed on either the inside or outside flange of cable tray.
- Guides are sold in pieces - two guides are required per tray.
- Maximum flange thickness 1¹/₈" (28.58 mm).

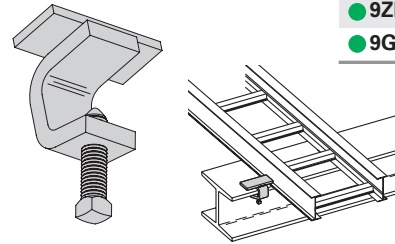

Catalog No.	Finish
● 9ZN-1249	Znplt
● 9G-1249	HDGAF

Nylon Pad

- Use for friction reduction.
- Hardness: Shore D80.
- Low friction coefficient.
- UV resistant.
- Excellent weatherability.
- UL - 94HB.

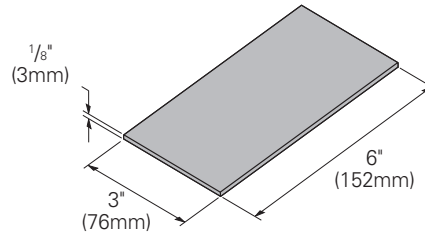

Catalog No.
● 99-PE36

Neoprene Roll

- Use for material isolation.
- 1¹/₈" x 2" x 25' roll.
- Hardness: Shore A60.
- Good weatherability.

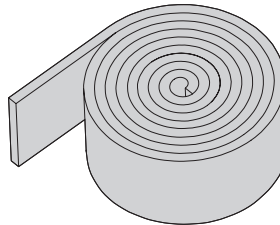

Catalog No.
● 99-NP300

DURA-BLOK™ Rooftop Support Bases with B22 Channel

- Designed as a superior rooftop support for cable tray,
- UV resistant and approved for most roofing material or other flat surfaces.
- Can be used with any of B-Line series cable tray clamps and guides.
- Ultimate Load Capacity: 1,000 lbs. (uniform load)



Catalog No.	Height x Width x Length in. (mm)
● DB10-28	5 ⁵ / ₈ x 6 x 28.0 (143 x 152 x 711)
● DB10-36	5 ⁵ / ₈ x 6 x 36.0 (143 x 152 x 914)
● DB10-42	5 ⁵ / ₈ x 6 x 42.0 (143 x 152 x 1067)
● DB10-50	5 ⁵ / ₈ x 6 x 50.0 (143 x 152 x 1270)
● DB10-60	5 ⁵ / ₈ x 6 x 60.0 (143 x 152 x 1524)



LEEDS credit available, base made from 100% recycled material.

General Note: Consult roofing manufacturer or engineer for roof load capacity. The weakest point may be the insulation board beneath the rubber membrane.

● Green = Fastest shipped items ● Black = Normal lead-time items ● Red = Normally long lead-time items

All dimensions in parentheses are millimeters unless otherwise specified.

Trapeze Support Kit

- Eaton's B-Line series trapeze kits provide the components required for a single trapeze support in one package. These kits are available in pre-galvanized steel with zinc-plated hardware, hot dip galvanized steel with 316 stainless steel hardware, or DURA GREEN™ painted steel with zinc-plated hardware.
- The SH channel provides the convenience of pre-punched slots, which eliminate the need for field drilling.
- The illustrated hardware is sealed in a plastic bag and boxed with the channel, which is pre-cut to the appropriate length as shown in the chart.
- Designed for use with 1/2" threaded rod. Order rod separately.

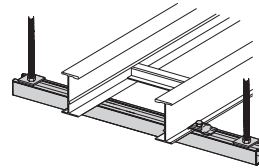
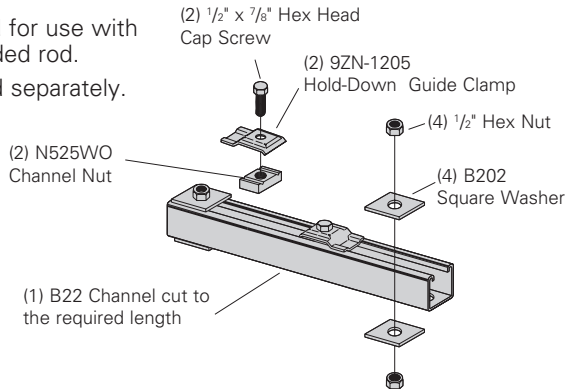

Catalog No.	Tray Width in. mm	Channel Length in. mm	Uniform Load lbs kN
● 9(*)-5506-22SH(†)	6 (152)	16 (406)	1350 (6.00)
● 9(*)-5509-22SH(†)	9 (229)	18 (457)	1250 (5.56)
● 9(*)-5512-22SH(†)	12 (305)	22 (559)	1125 (5.00)
● 9(*)-5518-22SH(†)	18 (457)	28 (711)	865 (3.85)
● 9(*)-5524-22SH(†)	24 (610)	34 (864)	700 (3.11)
● 9(*)-5530-22SH(†)	30 (762)	40 (1016)	590 (2.62)
● 9(*)-5536-22SH(†)	36 (914)	46 (1168)	510 (2.27)
● 9(*)-5542-22SH(†)	42 (1067)	52 (1321)	450 (2.00)

- (*) Insert **P** **G** or **GRN**
 - (†) Insert 3/8 for 3/8" threaded rod hardware.
- Safety factor of 3.0 on all loads.

Heavy Duty Trapeze Support Kit

- Eaton's B-Line series trapeze kits provide the components required for a single trapeze support in one package. These kits are available in pre-galvanized steel with zinc-plated hardware, hot dip galvanized steel with 316 stainless steel hardware, or DURA GREEN™ painted steel with zinc-plated hardware.
- The SH channel provides the convenience of pre-punched slots, which eliminates the need for field drilling.
- The illustrated hardware is sealed in a plastic bag and boxed with the channel, which is pre-cut to the appropriate length as shown in the chart.
- Designed for use with 1/2" threaded rod. Order rod separately.

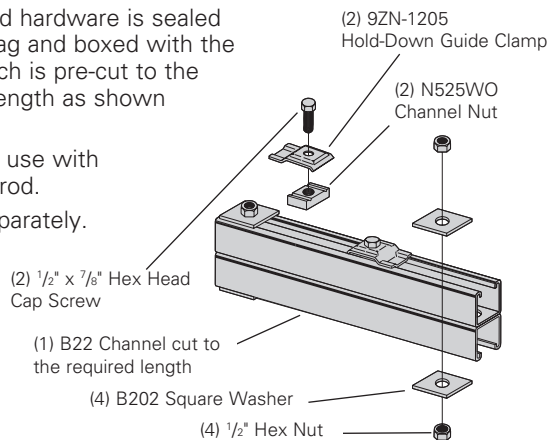

Catalog No.	Tray Width in. mm	Channel Length in. mm	Uniform Load lbs kN
● 9(*)-5506-22SHA	6 (152)	16 (406)	1350 (6.00)
● 9(*)-5509-22SHA	9 (229)	18 (457)	1350 (6.00)
● 9(*)-5512-22SHA	12 (305)	22 (559)	1350 (6.00)
● 9(*)-5518-22SHA	18 (457)	28 (711)	1350 (6.00)
● 9(*)-5524-22SHA	24 (610)	34 (864)	1350 (6.00)
● 9(*)-5530-22SHA	30 (762)	40 (1016)	1350 (6.00)
● 9(*)-5536-22SHA	36 (914)	46 (1168)	1350 (6.00)
● 9(*)-5542-22SHA	42 (1067)	52 (1321)	1350 (6.00)

- (*) Insert **P** **G** or **GRN**
- Safety factor of 3.0 on all loads.

Trapeze Hardware Kit

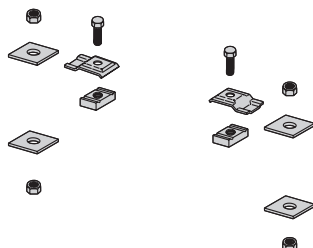

Catalog No.	● 9ZN-5500-1/2	● 9G-5500-1/2
In plastic bag	1 pr. 9ZN-1205 2 HHC Screw 1/2 x 7/8 ZN 2 N525 WO ZN 4 B202 ZN 1/2" sq washer 4 HN 1/2 ZN	1 pr. 9G-1205 2 HHC Screw 1/2 x 7/8 SS6 2 N525 WO SS6 4 B202 HDG 1/2" sq washer 4 HN 1/2 SS6

● Green = Fastest shipped items ● Black = Normal lead-time items ● Red = Normally long lead-time items

All dimensions in parentheses are millimeters unless otherwise specified.

Series 2, 3, 4, & 5 Aluminum - Accessories

Center Hung Tray Support

- Center Hung Cable Tray Support allows cable to be laid-in from both sides.
- Eliminates costly cable pulling and field cutting of cable tray supports. Labor costs are dramatically reduced.
- Required hardware and threaded rod material for trapeze assemblies are reduced by up to 50%.
- Designed for use with 1/2" threaded rod. (Order rod separately)
- Use with all aluminum and steel cable trays through 24" width.
- Load capacity is 700 lbs. (311kN) per support. Safety factor of 3.0. Eccentric loading is not to exceed a 60% vs. 40% load differential.
- The maximum recommended unsupported span length is 144"/12 ft. (3.66 m).
- Hardware shown is furnished.
- Finish available: Zinc Plated

Catalog No.	Tray Width		Channel Length	
	in.	(mm)	in.	(mm)
● 9ZN-5212	6", 9", 12"	(152, 228, 305)	18"	(457)
● 9ZN-5224	18", 24"	(457, 609)	30"	(762)

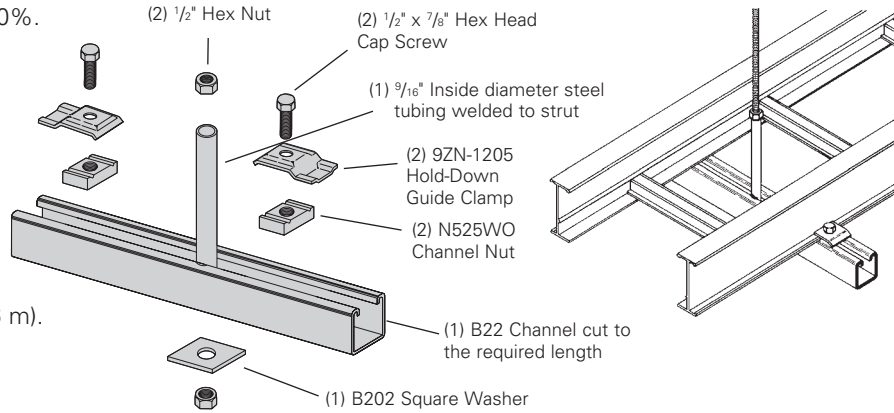

Center Hung Support Hardware Kit

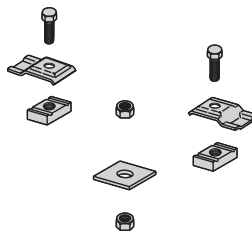

Catalog No.	● 9ZN-5200
In plastic bag	1 pr. 9ZN-1205 2 HHC Screw 1/2 x 7/8 ZN 2 N525 WO ZN 1 B202 ZN 1/2" sq washer 4 HN 1/2 ZN

Bracket (12" - 48")

- (*) Insert available finish: **ZN** **GRN** or **HDG**
- Safety Load Factor 2.5

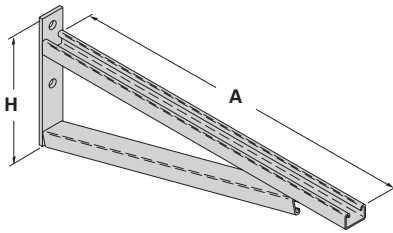

Bottom brace is B42 channel on B494-24 and smaller and B22 channel on B494-30 and larger

Catalog No.	Uniform Load lbs (kN)	Tray Width		'A'		'H'	
		in.	(mm)	in.	(mm)	in.	(mm)
● B494-12	2500 (11.12)	6 & 9	(152 & 229)	12	(305)	8 3/4	(222)
● B494-18	1700 (7.56)	12	(305)	18	(457)	8 3/4	(222)
● B494-24	1300 (5.78)	18	(457)	24	(610)	8 3/4	(222)
B494-30	1600 (7.11)	24	(610)	30	(762)	11 1/4	(286)
B494-36	1100 (4.89)	30	(762)	36	(914)	11 1/4	(286)
B494-42	980 (4.36)	36	(914)	42	(1067)	16	(406)
B494-48	980 (4.36)	42	(1067)	48	(1219)	16	(406)

For more dimensional data see Strut Systems catalog

Cantilever Bracket

- (*) Insert available finish: **ZN** **GRN** **HDG** **SS4** or **SS6**
- Safety Load Factor 2.5

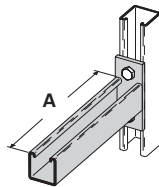

Catalog No.	Uniform Load		Tray Width		'A'	
	lbs	kN	in.	mm	in.	mm
B409-12	960	(4.27)	6 & 9	(152 & 229)	12	(305)
B409-18	640	(2.84)	12	(305)	18	(457)
B409-24	480	(2.13)	18	(457)	24	(610)

● Green = Fastest shipped items ● Black = Normal lead-time items ● Red = Normally long lead-time items

All dimensions in parentheses are millimeters unless otherwise specified.

Cantilever Bracket

- (*) Insert available finish: **ZN** **GRN** **HDG** or **SS4**
- Safety Load Factor 2.5

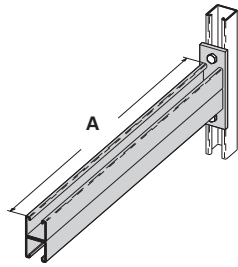

Catalog No.	Uniform Load		Tray Width		'A'	
	lbs	kN	in.	mm	in.	mm
B297-12	1660	(7.38)	6 & 9	(152 & 229)	12	(305)
B297-18	1100	(4.89)	12	(305)	18	(457)
B297-24	835	(3.71)	18	(457)	24	(610)
B297-30	665	(2.93)	24	(610)	30	(762)
B297-36	550	(2.44)	30	(762)	36	(914)
B297-42	465	(2.06)	36	(914)	42	(1067)

Underfloor Support (U-Bolts not included)

- Finishes available: **ZN**
- Safety Load Factor 2.5

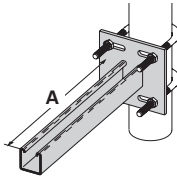

U-Bolt Size	Fits Pipe O.D.
B501-3/4	.841 - 1.050
B501-1	1.051 - 1.315
B501-1 1/4	1.316 - 1.660
B501-1 1/2	1.661 - 1.900
B501-2	1.901 - 2.375
B501-2 1/2	2.376 - 2.875

Catalog No.	Uniform Load		Tray Width		'A'	
	lbs	(kN)	in.	(mm)	in.	(mm)
B409UF-12	800	(3.56)	6 & 9	(152 & 229)	12	(305)
B409UF-21	450	(2.00)	12 & 18	(305 & 457)	21	(533)

Vertical Hanger Splice Plates

- Design load is 1500 lbs (6.67kN) per pair.
- Safety Factor of 2.5
- Furnished in pairs.
- Hole size: 9/16" (14mm) for 1/2" threaded rod.

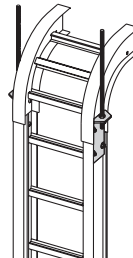
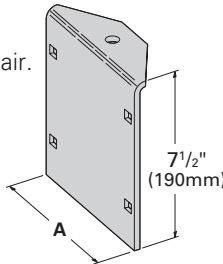

Catalog No.	Outside Cable Tray Ht.	'A'	
		in.	(mm)
● 9A-1224	4"	3.84	(97.54)
● 9A-1225	5"	4.73	(120.14)
● 9A-1226	6"	5.84	(148.34)
● 9A-1227	7"	6.84	(173.74)

Heavy Duty Hold Down Bracket

- Design load is 2000 lbs (8.89kN) per pair.
- Two bolt design.
- Sold in pairs.
- 3/8" cable tray attachment hardware provided.
- 3/8" support attachment hardware **not** provided.
- (*) Insert **ZN** **SS4** or **SS6**
- Recommended for support of vertical trays.

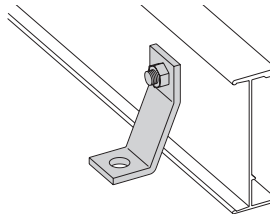

Catalog No.
9(*)-1241

Heavy Duty Hold Down Bracket

- Design load is 4000 lbs (17.79kN) per pair.
- Four bolt design.
- Sold in pairs.
- 3/8" cable tray attachment hardware provided
- 3/8" support attachment hardware **not** provided.
- (*) Insert **ZN** **SS4** or **SS6**
- Recommended for support of vertical trays.

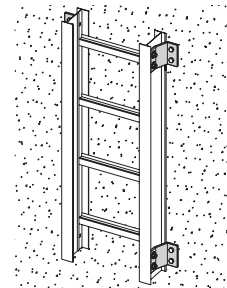
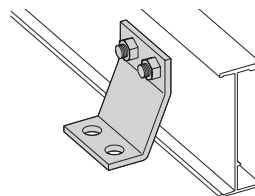

Catalog No.
9(*)-1242

Beam Clamp

- Finishes available: **ZN** **GRN** **HDG** or **SS4**
- Sold in pieces.
- Design load is 1200 lbs (5.34kN) per pair.
- Safety Load Factor 5.0.
- Order HHCS and Channel Nuts separately.

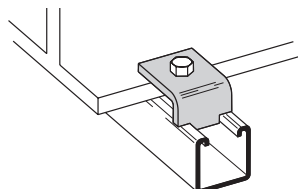

Catalog No.
B355

● Green = Fastest shipped items ● Black = Normal lead-time items ● Red = Normally long lead-time items

All dimensions in parentheses are millimeters unless otherwise specified.

Series 2, 3, 4, & 5 Aluminum - Accessories

Beam Clamp

- Finishes available: **ZN** or **HDG**
- Sold in pieces.
- *Design load when used in pairs.
Safety Load Factor 5.0

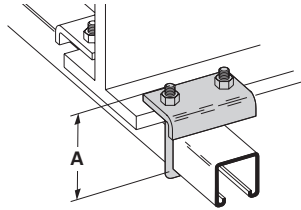

Catalog No.	Design Load lbs (kN)	'A' in. (mm)
B441-22	1200 (5.34)	3 ³ / ₈ (86)
B441-22A	1200 (5.34)	5 (127)

Beam Clamp

- Finishes available: **ZN** or **HDG**
- Sold in pieces.
- *Design load when used in pairs.
Safety Load Factor 5.0

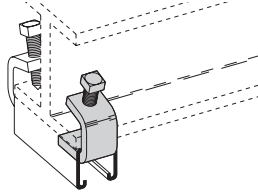

Catalog No.	B212-1/4	B212-3/8
Design Load *	600 lbs. (2.67kN)	1000 lbs. (4.45 kN)
Max. Flange Thick	3/4" (19 mm)	1 1/8" (28.6 mm)
Mat'l. Thickness	1/4" (6.3 mm)	3/8" (9.5 mm)

B305 Thru B308 & B321 Series Beam Clamps

- Finishes available: **ZN** or **HDG**
- Setscrew included.
- Safety Load Factor 5.0

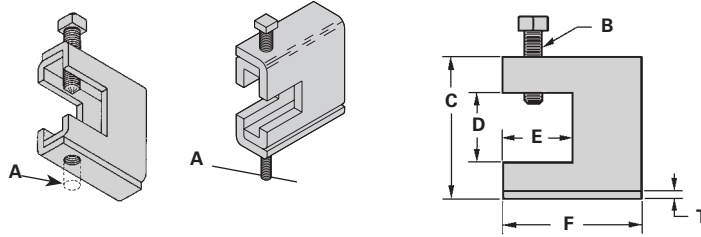

Catalog No.	Rod Size A	B	C in. (mm)	D in. (mm)	E in. (mm)	F in. (mm)	T in. (mm)	Design Load lbs (kN)
B305	3/8"-16	3/8"-16	2 ⁵ / ₁₆ (58.7)	7/8 (22.2)	1 1/8 (28.6)	2 1/2 (63.5)	11 Ga. (3.0)	600 (2.67)
B306	3/8"-16	1/2"-13	2 ⁷ / ₁₆ (61.9)	7/8 (22.2)	1 1/8 (28.6)	2 1/2 (63.5)	7 Ga. (4.5)	1100 (4.90)
B307	1/2"-13	1/2"-13	2 ⁷ / ₁₆ (61.9)	7/8 (22.2)	1 1/8 (28.6)	2 1/2 (63.5)	7 Ga. (4.5)	1100 (4.90)
B308	1/2"-13	1/2"-13	2 ⁹ / ₁₆ (65.1)	7/8 (22.2)	1 1/8 (28.6)	2 1/2 (63.5)	1/4 (6.3)	1500 (6.68)
B321-1	3/8"-16	1/2"-13	3 ⁹ / ₁₆ (90.5)	1 ¹¹ / ₁₆ (42.9)	1 ⁵ / ₈ (41.3)	3 1/4 (82.5)	1/4 (6.3)	1300 (5.79)
B321-2	1/2"-13	1/2"-13	3 ⁹ / ₁₆ (90.5)	1 ¹¹ / ₁₆ (42.9)	1 ⁵ / ₈ (41.3)	3 1/4 (82.5)	1/4 (6.3)	1400 (6.23)

Anchor Strap - for B305 thru B308 & B321 Series

- Finish available: **ZN**
- For a maximum beam thickness of 3/4" (19mm).
- For thicker beams, step up one flange width size.

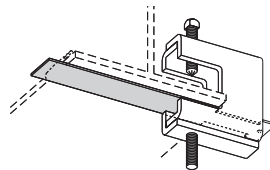

Catalog No.	Flange Width in. (mm)
B312-6	Up to 6 (Up to 152)
B312-9	6 - 9 (152 to 228)
B312-12	9 - 12 (228 to 305)

Beam Clamp

- Finish available: **ZN**
- Design Load 500 lbs. (2.22 kN)
- Safety Load Factor 5.0
- Recommended torque:
'J'-Hook Nut 125 In.-Lbs. (14.1 kN/m)
- Maximum flange thickness
of 3/4" (19mm).

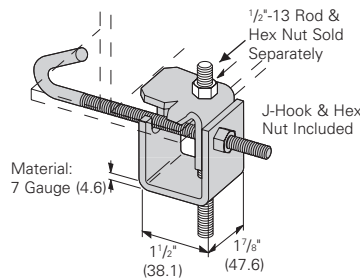

Catalog No.	For Flange Width in. (mm)	Wt./C lbs (kg)
B750-J4	3 - 6 (76.2 - 152.4)	109 (49.4)
B750-J6	5 - 9 (127.0 - 228.6)	124 (56.2)
B750-J9	8 - 12 (203.2 - 304.8)	135 (61.2)
B750-J12	11 - 15 (279.4 - 381.0)	147 (66.7)

'J'-Hook

- Finishes available: **ZN**
- Hex Nut included.

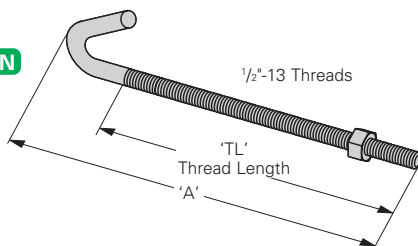

Catalog No.	'A' in. (mm)	'TL' in. (mm)	Wt./C lbs (kg)
B700-J4	8 1/2 (215.9)	5 (127.0)	44 (19.9)
B700-J6	11 1/2 (292.1)	6 (152.4)	53 (24.0)
B700-J9	12 1/4 (368.3)	6 (152.4)	63 (28.6)
B700-J12	17 1/2 (444.5)	6 (152.4)	78 (35.4)

● Green = Fastest shipped items ● Black = Normal lead-time items ● Red = Normally long lead-time items

All dimensions in parentheses are millimeters unless otherwise specified.

Covers

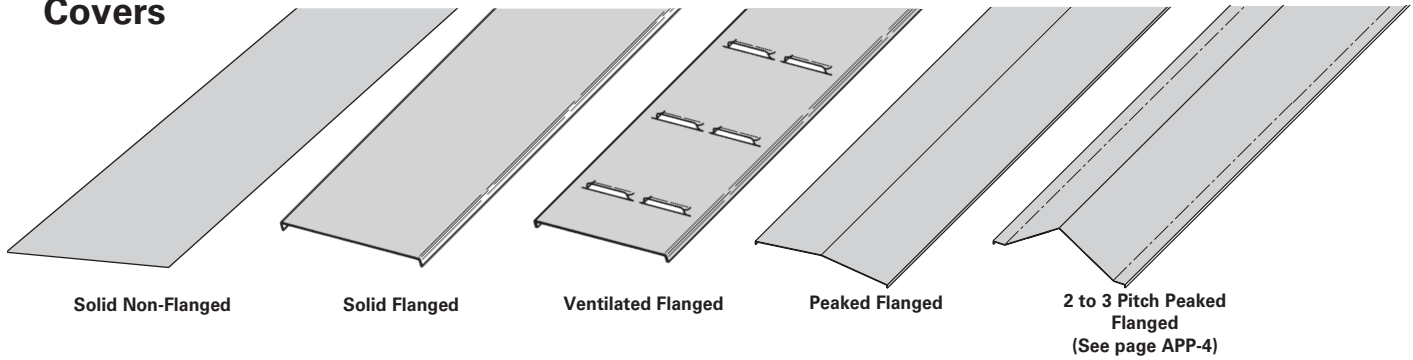

A full range of covers is available for straight sections and fittings.

Solid covers should be used when maximum enclosure of the cable is desired and no accumulation of heat is expected.

Ventilated covers provide an overhead cable shield, yet allow heat to escape.

We recommend that covers be placed on vertical cable tray runs to a height of 6 ft. (1.83 m) to 8 ft. (2.44 m) above the floor to isolate both cables and personnel. **Flanged covers** have a 1/2 in. (13 mm) flange. Cover clamps are not included with the cover and must be ordered separately. All **peaked covers** are flanged. Standard peaked covers have 1/2" peak. Special purpose peaked covers, having a 2 to 3 pitch, provide additional slope and material thickness. The 2 to 3 pitch fitting covers are of multiple piece, welded construction.

Aluminum Cover Part Numbering

Example: ^{Prefix} 80 7 A - 24 - 144

Cover Type

- 80 = Solid
- 81 = Ventilated
- 82 = Peaked

Detail

- 6 = Non-Flanged (80 & 81 type only)
- 7 = Flange

Material

- A = Aluminum

Tray Width

- 06 = 6"
- 09 = 9"
- 12 = 12"
- 18 = 18"
- 24 = 24"
- 30 = 30"
- 36 = 36"

Item Description

- For Straight Section Cover:
- 144 = 12 ft. (3.66 m)
 - 120 = 10 ft. (3.05 m)
 - 72 = 6 ft. (1.83 m)
 - 60 = 5 ft. (1.52 m)
- For fitting covers: Insert suffix of fitting to be covered. See example below.

Examples of Catalog Numbers for Fitting Covers:

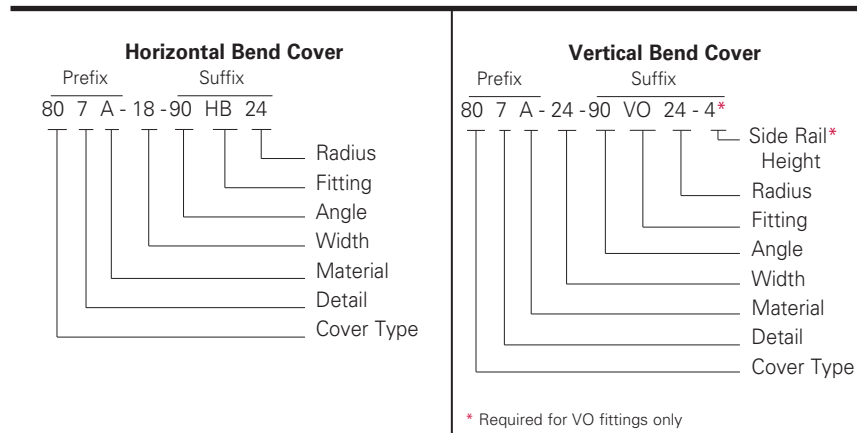

● Green = Fastest shipped items ● Black = Normal lead-time items ● Red = Normally long lead-time items

All dimensions in parentheses are millimeters unless otherwise specified.

Series 2, 3, 4, & 5 Aluminum - Accessories

Standard Cover Clamp

- For indoor service only.
- Setscrew included.
- Sold per piece.

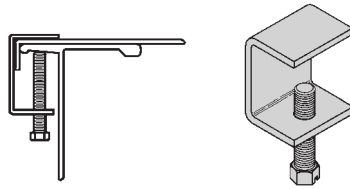

Tray Type	Catalog No.	Side Rail Height
Aluminum	● 9ZN-9012	All Sizes
	● 9A-9012	

Combination Cover and Hold Down Clamp

- Sold per piece.
- For indoor service only.

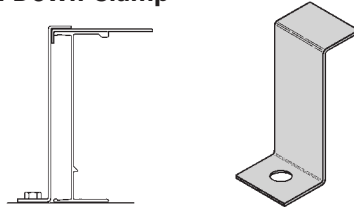

Tray Type	Catalog No.	Side Rail Height in. (mm)
Aluminum	● 9A-9043	4 (101)
	● 9A-9053	5 (127)
	● 9A-9063	6 (152)
	● 9A-9073	7 (78)

Raised Cover Clamp

- For indoor service only.
- For use with flanged covers only.
- † Specify gap of 1", 2", 3" or 4".

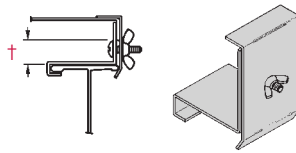

Tray Type	Catalog No.	Side Rail Height
Aluminum	● 9ZN-9112-†	4 & 5 Deep
	● 9ZN-9113-†	6 & 7 Deep

Heavy Duty Cover Clamp

- Recommended for outdoor service.
- (±) Insert tray width
- † Add P to Catalog No. for peaked cover clamp.

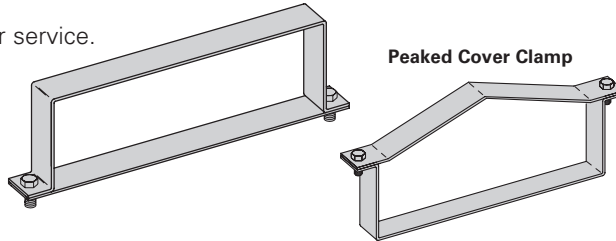

Catalog No.	Side Rail Height in. mm
● 9A-(±)-9044†	4 (101)
● 9A-(±)-9054†	5 (127)
● 9A-(±)-9064†	6 (152)
● 9A-(±)-9074†	7 (178)

Quantity of Standard Cover Clamps Required

Notes:

When using the Heavy Duty Cover Clamp, only on-half the number of clamps stated above is required.

Additional clamps may be necessary in extreme wind applications.

Straight Section 60" or 72"	4 pcs.
Straight Section 120" or 144"	6 pcs.
Horizontal/Vertical Bends	4 pcs.
Tees	6 pcs.
Crosses	8 pcs.

Cover Joint Strip

- Used to join covers
- Plastic
- Only for use on flat covers
- Color - gray.
- (±) Insert tray width

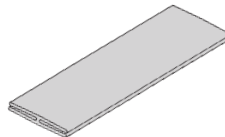

Catalog No.
● 99-9980-(±)

Cable Cleats

(see pages N-1 thru N-5) Standard

Trefoil
Cable
Cleats



Single
Cable
Cleats



● Green = Fastest shipped items ● Black = Normal lead-time items ● Red = Normally long lead-time items

All dimensions in parentheses are millimeters unless otherwise specified.

Section 1- Acceptable Manufacturers

- 1.01 Manufacturer: Subject to compliance with these specifications, Eaton's B-Line series cable tray systems shall be as manufactured by Eaton.

Section 2- Cable Tray Sections and Components

- 2.01 General: Except as otherwise indicated, provide metal cable trays, of types, classes and sizes indicated; with splice plates, bolts, nuts and washers for connecting units. Construct units with rounded edges and smooth surfaces; in compliance with applicable standards; and with the following additional construction features. Cable tray shall be installed according to the latest revision of NEMA VE 2.
- 2.02 Materials and Finish: Straight section and fitting side rails and rungs shall be extruded from Aluminum Association Alloy 6063. All fabricated parts shall be made from Aluminum Association Alloy 5052.
- 2.03 Ladder Cable Trays shall consist of two longitudinal members (side rails) with transverse members (rungs) welded to the side rails. Rungs shall be spaced [6] [9] [12] inches apart. Rung spacing in radiused fittings shall be industry standard 9" and measured at the center of the tray's width. Each rung must be capable of supporting a 200 lb. concentrated load at the center of the cable tray over and above the cable load with a safety factor of 1.5.
- 2.04 Cable tray loading depth shall be [3] [4] [5] [6] inches per NEMA VE 1.
- 2.05 Straight sections shall have side rails fabricated as I-beams. Straight sections shall be supplied in standard [12 foot] [24 foot] [10 foot (3 m)] [20 foot (6 m)] lengths.
- 2.06 Cable tray widths shall be [6] [9] [12] [18] [24] [30] [36] inches or as shown on drawings.
- 2.06 Splice plates shall be the Wedge-Lock design with 4 nuts and bolts per plate. The resistance of fixed splice connections between an adjacent section of tray shall not exceed 0.00033 ohm.
- 2.08 All fittings must have a minimum radius of [12] [24] [36] [48] inches.

Section 3- Loading Capacities and Testing

- 3.01 Cable tray shall be capable of carrying a uniformly distributed load of _____ lbs./ft. on a _____ ft. support span with a safety factor of 1.5 when supported as a simple span and tested per NEMA VE 1 5.2. In addition to the uniformly distributed load the cable tray shall support 200 lbs. concentrated load at mid-point of span. Load and safety factors specified are applicable to both the side rails and rung capacities. Cable tray shall be made to manufacturing tolerances as specified by NEMA.
- 3.02 Upon request, manufacturer shall provide test reports in accordance with the latest revision of NEMA VE 1 or CSA C22.2 No. 126.



How The Service Advisor Works

We know that your time is important! That's why the color-coding system in this catalog is designed to help you select products that fit your service needs. Products are marked to indicate the typical lead time for orders of 50 pieces or less.

Customer: How do I select my straight sections, covers, or fittings so that I get the quickest turnaround?

Service Advisor: Each part of our selection chart is shown in colors. If any section of a part number is a different color, the part will typically ship with the longer lead time represented by the colors.

- Green = Fastest shipped items
- Black = Normal lead-time items
- Red = Normally long lead-time items

Example: 258G 12 - 24 - 144

● ● ● ●

● ● ● ●

Part will have a long lead time because of the 258G material.

Changing the part number from 258G to 258P will change the coding to black and reduce lead time.

3" NEMA VE 1 Loading Depth 4" Side Rail Height

Straight Section Part Numbering

Prefix
Example: **248 P 09 - 24 - 144**

Series	Material	*Type	*Width	Length
● 248	● P = Pre-Galvanized ● G = HDGAF	SB = Solid Bottom ● 06 = 6" rung spacing ● 09 = 9" rung spacing ● 12 = 12" rung spacing	● 06 = 6" ● 09 = 9" ● 12 = 12" ● 18 = 18" ● 24 = 24" ● 30 = 30" ● 36 = 36"	● ① 144 = 12 ft. 248 ● ② 120 = 10 ft. ● ① 240 = 20 ft. 346 ● ② 144 = 12 ft. ● ① 240 = 20 ft. 444 ● ② 288 = 24 ft.

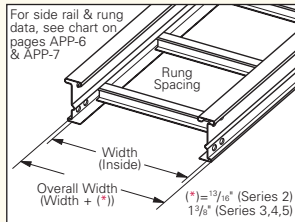

① Primary Length.
② Secondary Length.

See page C-23 for explanation of lengths.

See page APP-1 for additional rung options. *Special sizes available.



Ladder Type
(Specify Rung Spacing)

● Green = Fastest shipped items ● Black = Normal lead-time items ● Red = Normally long lead-time items

All dimensions in parentheses are millimeters unless otherwise specified.

3" NEMA VE 1 Loading Depth 4" Side Rail Height

Values are based on simple beam tests per NEMA VE 1 on 36" wide cable tray with rungs spaced on 12" centers. Cable trays will support without collapse a 200 lb. (90.7 kg) concentrated load over and above published loads. Published load safety factor is 1.5. To convert 1.5 safety factor to 2.0, multiply published load by 0.75. To obtain mid-span deflection, multiply a load by the deflection multiplier. Cable tray must be supported on spans shorter than or equal to the length of the cable tray being installed.

Individual rungs will support without collapse a 200 lb. (90.7 kg) concentrated load applied at the mid-span of the rung, over and above the NEMA rated cable load with a 1.5 safety factor for highlighted NEMA spans and loads.

B-Line Series	Side Rail Dimensions	NEMA, CSA & UL Classifications	Span ft	Load lbs/ft	Deflection Multiplier	Design Factors for Two Rails	Span meters	Load kg/m	Deflection Multiplier	Design Factors for Two Rails
248		NEMA: 16A, 12C CSA: D1-3m UL Cross-Sectional Area: 0.40 in ²	6	412*	0.0007	Area = 0.62 in ² Sx = 0.64 in ³ Ix = 1.43 in ⁴	1.8	613*	0.012	Area = 4.00 cm ² Sx = 10.49 cm ³ Ix = 59.52 cm ⁴
			8	232	0.0022		2.4	345	0.038	
			10	148	0.0054		3.0	221	0.093	
			12	103	0.011		3.7	153	0.192	
			14	76	0.021		4.3	113	0.356	
			16	58	0.036		4.9	86	0.607	

B-Line Series	Side Rail Dimensions	NEMA, CSA & UL Classifications	Span ft	Load lbs/ft	Deflection Multiplier	Design Factors for Two Rails	Span meters	Load kg/m	Deflection Multiplier	Design Factors for Two Rails
346		NEMA: 20A, 16B CSA: D1-6m UL Cross-Sectional Area: 0.70 in ²	10	252	0.0036	Area = 0.89 in ² Sx = 0.96 in ³ Ix = 2.22 in ⁴	3.0	375	0.060	Area = 5.74 cm ² Sx = 15.73 cm ³ Ix = 92.40 cm ⁴
			12	175	0.0072		3.7	260	0.124	
			14	129	0.013		4.3	191	0.229	
			16	98	0.023		4.9	146	0.391	
			18	78	0.037		5.5	116	0.626	
			20	63	0.056		6.1	94	0.955	

B-Line Series	Side Rail Dimensions	NEMA, CSA & UL Classifications	Span ft	Load lbs/ft	Deflection Multiplier	Design Factors for Two Rails	Span meters	Load kg/m	Deflection Multiplier	Design Factors for Two Rails
444		NEMA: 20B, 16C CSA: E-3m UL Cross-Sectional Area: 1.00 in ²	12	253	0.0055	Area = 1.19 in ² Sx = 1.27 in ³ Ix = 2.94 in ⁴	3.7	376	0.093	Area = 7.68 cm ² Sx = 20.81 cm ³ Ix = 122.37 cm ⁴
			16	142	0.027		4.9	212	0.295	
			18	112	0.028		5.5	167	0.473	
			20	91	0.042		6.1	135	0.721	
			22	75	0.062		6.7	112	1.055	
			24	63	0.088		7.3	94	1.495	

*When using 18" rung spacing, load capacity is limited to 394 lbs/ft (586.272 kg/m) for 30" cable tray width and 325 lbs/ft (483.6 kg/m) for 36" cable tray width. When cable trays are used in continuous spans, the deflection of the cable tray is reduced by as much as 50%. Design factors: Ix = Moment of Inertia, Sx = Section Modulus.

All dimensions in parentheses are millimeters unless otherwise specified.

4" NEMA VE 1 Loading Depth 5" Side Rail Height

Straight Section Part Numbering

Prefix
Example: **258 P 09 - 24 - 144**

Series

- **258**
- **356**
- **454**

Material

- **P** = Pre-Galvanized
- **G** = HDGAF

*Type

- **SB** = Solid Bottom
- **06** = 6" rung spacing
- **09** = 9" rung spacing
- **12** = 12" rung spacing

*Width

- **06** = 6"
- **09** = 9"
- **12** = 12"
- **18** = 18"
- **24** = 24"
- **30** = 30"
- **36** = 36"

Length

- ① **144** = 12 ft. 258
- ② 120 = 10 ft.
- ① **240** = 20 ft. 356
- ② 144 = 12 ft.
- ① **240** = 20 ft. 454
- ② 288 = 24 ft.

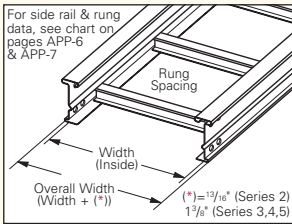

- ① Primary Length.
- ② Secondary Length.

See page C-23 for explanation of lengths.

See page APP-1 for additional rung options. *Special sizes available.

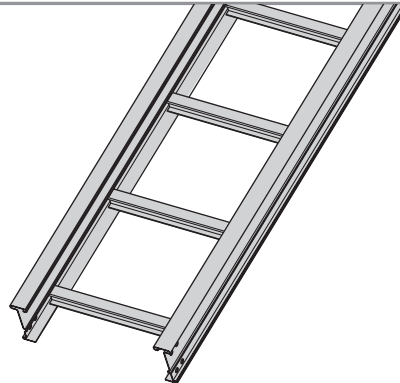

Ladder Type
(Specify Rung Spacing)

● Green = Fastest shipped items ● Black = Normal lead-time items ● Red = Normally long lead-time items

All dimensions in parentheses are millimeters unless otherwise specified.

4" NEMA VE 1 Loading Depth 5" Side Rail Height

Values are based on simple beam tests per NEMA VE 1 on 36" wide cable tray with rungs spaced on 12" centers. Cable trays will support without collapse a 200 lb. (90.7 kg) concentrated load over and above published loads. Published load safety factor is 1.5. To convert 1.5 safety factor to 2.0, multiply published load by 0.75. To obtain mid-span deflection, multiply a load by the deflection multiplier. Cable tray must be supported on spans shorter than or equal to the length of the cable tray being installed.

Individual rungs will support without collapse a 200 lb. (90.7 kg) concentrated load applied at the mid-span of the rung, over and above the NEMA rated cable load with a 1.5 safety factor for highlighted NEMA spans and loads.

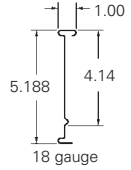
B-Line Series	Side Rail Dimensions	NEMA, CSA & UL Classifications	Span ft	Load lbs/ft	Deflection Multiplier	Design Factors for Two Rails	Span meters	Load kg/m	Deflection Multiplier	Design Factors for Two Rails
258		NEMA: 16A, 12C CSA: D1-3m UL Cross-Sectional Area: 0.40 in ²	6	436*	0.0004	Area = 0.71 in ² Sx = 0.89 in ³ Ix = 2.44 in ⁴	1.8	649*	0.007	Area = 4.58 cm ² Sx = 14.58 cm ³ Ix = 101.56 cm ⁴
			8	245	0.0013		2.4	365	0.022	
			10	157	0.0032		3.0	234	0.054	
			12	109	0.0066		3.7	162	0.113	
			14	80	0.012		4.3	119	0.209	
			16	61	0.021		4.9	91	0.356	

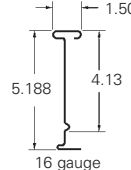
B-Line Series	Side Rail Dimensions	NEMA, CSA & UL Classifications	Span ft	Load lbs/ft	Deflection Multiplier	Design Factors for Two Rails	Span meters	Load kg/m	Deflection Multiplier	Design Factors for Two Rails
356		NEMA: 20A, 16C CSA: D1-6m UL Cross-Sectional Area: 0.70 in ²	10	276	0.0021	Area = 1.00 in ² Sx = 1.31 in ³ Ix = 3.73 in ⁴	3.0	411	0.036	Area = 6.45 cm ² Sx = 21.47 cm ³ Ix = 155.25 cm ⁴
			12	192	0.0043		3.7	285	0.074	
			14	141	0.0080		4.3	210	0.136	
			16	108	0.014		4.9	160	0.233	
			18	85	0.022		5.5	127	0.373	
			20	69	0.033		6.1	103	0.568	

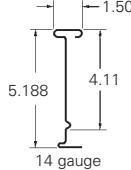
B-Line Series	Side Rail Dimensions	NEMA, CSA & UL Classifications	Span ft	Load lbs/ft	Deflection Multiplier	Design Factors for Two Rails	Span meters	Load kg/m	Deflection Multiplier	Design Factors for Two Rails
454		NEMA: 20C CSA: E-6m UL Cross-Sectional Area: 1.00 in ²	12	294	0.0032	Area = 1.34 in ² Sx = 1.75 in ³ Ix = 4.96 in ⁴	3.7	438	0.055	Area = 8.65 cm ² Sx = 28.68 cm ³ Ix = 206.45 cm ⁴
			16	166	0.010		4.9	246	0.175	
			18	131	0.016		5.5	195	0.280	
			20	106	0.026		6.1	158	0.427	
			22	88	0.037		6.7	130	0.625	
			24	74	0.052		7.3	110	0.886	

*When using 18" rung spacing, load capacity is limited to 394 lbs/ft (586.272 kg/m) for 30" cable tray width and 325 lbs/ft (483.6 kg/m) for 36" cable tray width. When cable trays are used in continuous spans, the deflection of the cable tray is reduced by as much as 50%. Design factors: Ix = Moment of Inertia, Sx = Section Modulus.

All dimensions in parentheses are millimeters unless otherwise specified.

5" NEMA VE 1 Loading Depth 6" Side Rail Height

Straight Section Part Numbering

Prefix
Example: **268 P 09 - 24 - 144**

Series

- 268
- 366
- 464

Material

- P = Pre-Galvanized
- G = HDGAF

*Type

- SB = Solid Bottom
- 06 = 6" rung spacing
- 09 = 9" rung spacing
- 12 = 12" rung spacing

*Width

- 06 = 6"
- 09 = 9"
- 12 = 12"
- 18 = 18"
- 24 = 24"
- 30 = 30"
- 36 = 36"

Length

- ① 144 = 12 ft. 268
- ② 120 = 10 ft.
- ① 240 = 20 ft. 366
- ② 144 = 12 ft.
- ① 240 = 20 ft. 464
- ② 288 = 24 ft.

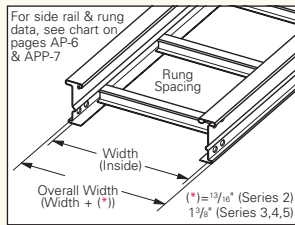

① Primary Length.
② Secondary Length.

See page C-23 for explanation of lengths.

See page APP-1 for additional rung options. *Special sizes available.



Ladder Type
(Specify Rung Spacing)

● Green = Fastest shipped items ● Black = Normal lead-time items ● Red = Normally long lead-time items

All dimensions in parentheses are millimeters unless otherwise specified.

5" NEMA VE 1 Loading Depth 6" Side Rail Height

Values are based on simple beam tests per NEMA VE 1 on 36" wide cable tray with rungs spaced on 12" centers. Cable trays will support without collapse a 200 lb. (90.7 kg) concentrated load over and above published loads. Published load safety factor is 1.5. To convert 1.5 safety factor to 2.0, multiply published load by 0.75. To obtain mid-span deflection, multiply a load by the deflection multiplier. Cable tray must be supported on spans shorter than or equal to the length of the cable tray being installed.

Individual rungs will support without collapse a 200 lb. (90.7 kg) concentrated load applied at the mid-span of the rung, over and above the NEMA rated cable load with a 1.5 safety factor for highlighted NEMA spans and loads.

B-Line Series	Side Rail Dimensions	NEMA, CSA & UL Classifications	Span ft	Load lbs/ft	Deflection Multiplier	Design Factors for Two Rails	Span meters	Load kg/m	Deflection Multiplier	Design Factors for Two Rails
268		NEMA: 16A, 12C CSA: D1-3m UL Cross-Sectional Area: 0.70 in ²	6	440*	0.0003	Area = 0.80 in ² Sx = 1.18 in ³ Ix = 3.81 in ⁴	1.8	655*	0.005	Area = 5.16 cm ² Sx = 19.34 cm ³ Ix = 158.58 cm ⁴
			8	248	0.0008		2.4	368	0.014	
			10	158	0.0020		3.0	236	0.035	
			12	110	0.0042		3.7	164	0.072	
			14	81	0.0078		4.3	120	0.134	
			16	62	0.013		4.9	92	0.228	

B-Line Series	Side Rail Dimensions	NEMA, CSA & UL Classifications	Span ft	Load lbs/ft	Deflection Multiplier	Design Factors for Two Rails	Span meters	Load kg/m	Deflection Multiplier	Design Factors for Two Rails
366		NEMA: 20B, 16C CSA: E-6m UL Cross-Sectional Area: 1.00 in ²	10	300	0.0014	Area = 1.11 in ² Sx = 1.71 in ³ Ix = 5.74 in ⁴	3.0	446	0.023	Area = 7.16 cm ² Sx = 28.02 cm ³ Ix = 238.92 cm ⁴
			12	208	0.0028		3.7	310	0.048	
			14	153	0.0052		4.3	228	0.089	
			16	117	0.0089		4.9	174	0.151	
			18	93	0.014		5.5	138	0.242	
			20	75	0.022		6.1	112	0.369	

B-Line Series	Side Rail Dimensions	NEMA, CSA & UL Classifications	Span ft	Load lbs/ft	Deflection Multiplier	Design Factors for Two Rails	Span meters	Load kg/m	Deflection Multiplier	Design Factors for Two Rails
464		NEMA: 20C CSA: E-6m UL Cross-Sectional Area: 1.00 in ²	12	342*	0.002	Area = 1.49 in ² Sx = 2.27 in ³ Ix = 7.65 in ⁴	3.7	508*	0.035	Area = 9.61 cm ² Sx = 37.36 cm ³ Ix = 318.42 cm ⁴
			16	192	0.007		4.9	286	0.113	
			18	152	0.011		5.5	226	0.182	
			20	123	0.016		6.1	183	0.277	
			22	102	0.024		6.7	151	0.406	
			24	85	0.034		7.3	127	0.574	

*When using 18" rung spacing, load capacity is limited to 394 lbs/ft (586.272 kg/m) for 30" cable tray width and 325 lbs/ft (483.6 kg/m) for 36" cable tray width. When cable trays are used in continuous spans, the deflection of the cable tray is reduced by as much as 50%. Design factors: Ix = Moment of Inertia, Sx = Section Modulus.

All dimensions in parentheses are millimeters unless otherwise specified.

6" NEMA VE 1 Loading Depth 7" Side Rail Height

Straight Section Part Numbering

Prefix
Example: **378 P 09 - 24 - 144**

Series

- 378

- 476

- 574

Material

- **P** = Pre-Galvanized
- **G** = HDGAF

*Type

- SB** = Solid Bottom
- 06 = 6" rung spacing
- 09 = 9" rung spacing
- 12 = 12" rung spacing

*Width

- 06 = 6"
- 09 = 9"
- 12 = 12"
- 18 = 18"
- 24 = 24"
- 30 = 30"
- 36 = 36"

Length

- ① 144 = 12 ft. 378
- ② 120 = 10 ft.

- ① 240 = 20 ft. 476
- ② 144 = 12 ft.

- ① 240 = 20 ft. 574
- ② 288 = 24 ft.

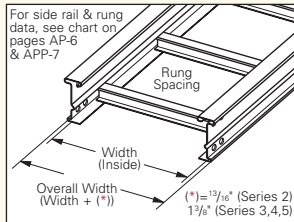

- ① Primary Length.
- ② Secondary Length.

See page C-23 for explanation of lengths.

See page APP-1 for additional rung options. *Special sizes available.

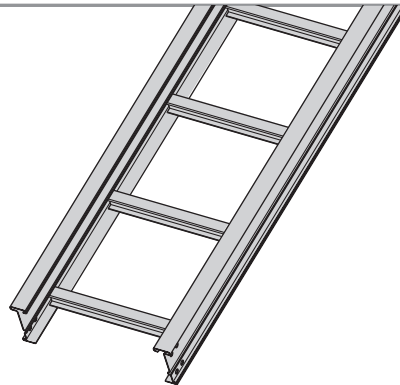

Ladder Type
(Specify Rung Spacing)

● Green = Fastest shipped items ● Black = Normal lead-time items ● Red = Normally long lead-time items

All dimensions in parentheses are millimeters unless otherwise specified.

6" NEMA VE 1 Loading Depth 7" Side Rail Height

Values are based on simple beam tests per NEMA VE 1 on 36" wide cable tray with rungs spaced on 12" centers. Cable trays will support without collapse a 200 lb. (90.7 kg) concentrated load over and above published loads. Published load safety factor is 1.5. To convert 1.5 safety factor to 2.0, multiply published load by 0.75. To obtain mid-span deflection, multiply a load by the deflection multiplier. Cable tray must be supported on spans shorter than or equal to the length of the cable tray being installed.

Individual rungs will support without collapse a 200 lb. (90.7 kg) concentrated load applied at the mid-span of the rung, over and above the NEMA rated cable load with a 1.5 safety factor for highlighted NEMA spans and loads.

B-Line Series	Side Rail Dimensions	NEMA, CSA & UL Classifications	Span ft	Load lbs/ft	Deflection Multiplier	Design Factors for Two Rails	Span meters	Load kg/m	Deflection Multiplier	Design Factors for Two Rails
378		NEMA: 20A, 16B CSA: D1-3m UL Cross-Sectional Area: 0.70 in ²	8	319	0.0006	Area = 1.01 in ² Sx = 1.77 in ³ Ix = 6.90 in ⁴	2.4	474	0.009	Area = 6.52 cm ² Sx = 29.01 cm ³ Ix = 287.20 cm ⁴
			10	204	0.0014		3.0	304	0.023	
			12	142	0.0028		3.7	211	0.048	
			14	104	0.0052		4.3	155	0.089	
			16	80	0.0089		4.9	119	0.151	
			18	63	0.014		5.5	94	0.242	
			20	51	0.022		6.1	76	0.369	

B-Line Series	Side Rail Dimensions	NEMA, CSA & UL Classifications	Span ft	Load lbs/ft	Deflection Multiplier	Design Factors for Two Rails	Span meters	Load kg/m	Deflection Multiplier	Design Factors for Two Rails
476		NEMA: 20B, 16C CSA: D1-6m UL Cross-Sectional Area: 1.00 in ²	12	214	0.0019	Area = 1.22 in ² Sx = 2.14 in ³ Ix = 8.30 in ⁴	3.7	318	0.033	Area = 7.87 cm ² Sx = 35.07 cm ³ Ix = 345.47 cm ⁴
			16	129	0.0061		4.9	179	0.105	
			18	95	0.010		5.5	141	0.168	
			20	77	0.015		6.1	115	0.255	
			22	64	0.022		6.7	95	0.374	
			24	53	0.031		7.3	80	0.529	

B-Line Series	Side Rail Dimensions	NEMA, CSA & UL Classifications	Span ft	Load lbs/ft	Deflection Multiplier	Design Factors for Two Rails	Span meters	Load kg/m	Deflection Multiplier	Design Factors for Two Rails
574		NEMA: 20C CSA: E-6m UL Cross-Sectional Area: 1.50 in ²	12	361	0.0014	Area = 1.64 in ² Sx = 2.87 in ³ Ix = 11.10 in ⁴	3.7	537	0.025	Area = 10.58 cm ² Sx = 47.03 cm ³ Ix = 462.02 cm ⁴
			16	203	0.0046		4.9	302	0.078	
			18	160	0.0073		5.5	239	0.125	
			20	130	0.011		6.1	193	0.191	
			22	107	0.016		6.7	160	0.280	
			24	90	0.023		7.3	134	0.396	

When cable trays are used in continuous spans, the deflection of the cable tray is reduced by as much as 50%.
 Design factors: Ix = Moment of Inertia, Sx = Section Modulus.

All dimensions in parentheses are millimeters unless otherwise specified.

Series 2, 3, 4, & 5 Steel - Accessories

Series 2, 3, 4, & 5 Steel

Splice Plates

- Standard 8-hole pattern for all steel splice plates.
- Furnished in pairs with hardware.
- One pair including hardware provided with straight section. (Expansion splice quantity subtracted)
- Boxed in pairs with hardware.
- (*) Insert **ZN** or **G**

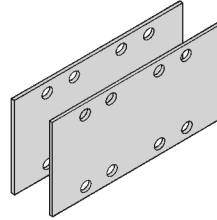

Catalog No.	Height	
	in.	mm
9(*)-8004	4	(101)
9(*)-8005	5	(127)
9(*)-8006	6	(152)
9(*)-8007	7	(178)

Expansion Splice Plates

- Expansion plates allow for one inch expansion or contraction of the cable tray, or where expansion joints occur in the support structure.
- Furnished in pairs with hardware.
- Bonding Jumpers are required on each siderail. Order Separately.
- (*) Insert **ZN** or **G**

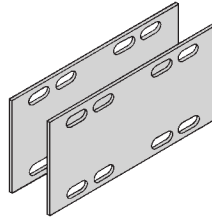

For heavy duty expansion splice plates see page APP-3.

Catalog No.	Height	
	in.	mm
9(*)-8014	4	(101)
9(*)-8015	5	(127)
9(*)-8016	6	(152)
9(*)-8017	7	(178)

Requires supports within 24" on both sides, per NEMA VE 2.

Universal Splice Plates

- Used to splice to existing cable tray systems.
- Furnished in pairs with hardware.
- (*) Insert **ZN** or **G**

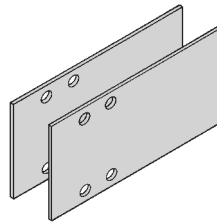

Catalog No.	Height	
	in.	mm
9(*)-8004-1/2	4	(101)
9(*)-8005-1/2	5	(127)
9(*)-8006 -1/2	6	(152)
9(*)-8007 -1/2	7	(178)

Step Down Splice Plates

- These splice plates are offered for connecting cable tray sections having side rails of different heights.
- Furnished in pairs with hardware.
- (*) Insert **ZN** or **G**

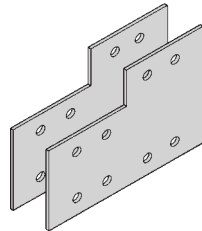

Catalog No.	Height	
	in.	mm
9(*)-8045	5 to 4	(127 to 101)
9(*)-8046	6 to 4	(152 to 101)
9(*)-8060	6 to 5	(152 to 127)
9(*)-8047	7 to 4	(178 to 101)
9(*)-8061	7 to 5	(178 to 127)
9(*)-8062	7 to 6	(178 to 152)

Vertical Adjustable Splice Plates

- These plates provide for changes in elevation that do not conform to standard vertical fittings.
- Furnished in pairs with hardware.
- **Bonding Jumpers not required.**
- (*) Insert **G** or **P**

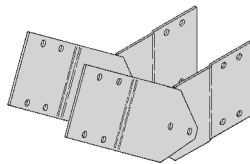

Catalog No.	Height	
	in.	mm
9(*)-8024	4	(101)
9(*)-8025	5	(127)
9(*)-8026	6	(152)
9(*)-8027	7	(178)

Branch Pivot Connectors

- Branch from existing cable tray runs at any point.
- Pivot to any required angle.
- UL Classified for grounding (bonding jumpers not required).
- Furnished in pairs with hardware.
- (*) Insert **ZN** or **G**

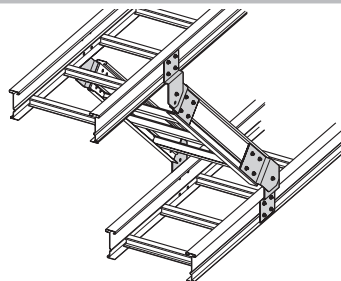

Catalog No.	Height	
	in.	mm
9(*)-8244	4	(101)
9(*)-8245	5	(127)
9(*)-8246	6	(152)
9(*)-8247	7	(178)

● Green = Fastest shipped items ● Black = Normal lead-time items ● Red = Normally long lead-time items

All dimensions in parentheses are millimeters unless otherwise specified.

Horizontal Adjustable Splice Plates

- Offered to adjust a cable tray run for changes in direction in a horizontal plane that do not conform to standard horizontal fittings.
- Furnished in pairs with hardware.
- Bonding jumpers **not** required.
- (*) Insert **ZN** or **G**
- (X) Insert 4, 5, 6 or 7 for side rail height.

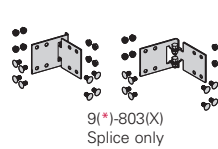

9(*)-803(X)-12 or 9(*)-803(X)-36
One pair splice plates with extensions.

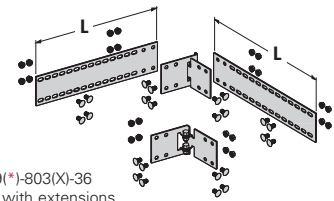

Catalog No.	Cable Tray End Cut	Thru Tray Width		'L'
		in.	(mm)	in. (mm)
9(*)-803(X)	Mitered	36	(914)	N/A (NA)
9(*)-803(X)-12	Not mitered	12	(305)	16 (406)
9(*)-803(X)-36	Not mitered	36	(914)	41(1041)

Requires supports within 24" on both sides, per NEMA VE 2.

Offset Reducing Splice Plate

- This plate is used for joining cable trays having different widths. When used in pairs they form a straight reduction; when used singly with a standard splice plate, they form an offset reduction.
- Furnished as one plate with hardware.
- (‡) Insert reduction
- (*) Insert **G** or **P**

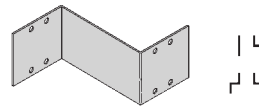

Catalog No.	Height	
	in.	mm
9(*)-8064-(‡)	4	(101)
9(*)-8065-(‡)	5	(127)
9(*)-8066-(‡)	6	(152)
9(*)-8067-(‡)	7	(178)

Tray to Box Splice Plates

- Used to attach the end of a cable tray run to a distribution box or control panel.
- Furnished in pairs with hardware.
- (*) Insert **G** or **P**

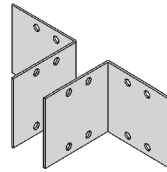

Catalog No.	Height	
	in.	mm
9(*)-8054	4	(101)
9(*)-8055	5	(127)
9(*)-8056	6	(152)
9(*)-8057	7	(178)

Frame Type Box Connector

- Designed to attach the end of a cable tray run to a distribution cabinet or control center to help reinforce the box at the point of entry.
- Furnished with tray connection hardware.
- (*) Insert **ZN** or **G**
- (‡) Insert tray width

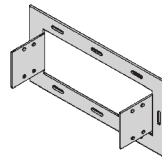

Catalog No.	Height	
	in.	mm
9(*)-8074-(‡)	4	(101)
9(*)-8075-(‡)	5	(127)
9(*)-8076-(‡)	6	(152)
9(*)-8077-(‡)	7	(178)

Blind End

- This plate forms a closure for a dead end cable tray.
- Furnished as one plate with hardware.
- (*) Insert **G** or **P**
- (‡) Insert tray width

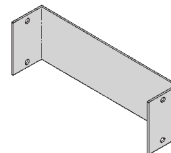

Catalog No.	Height	
	in.	mm
9(*)-8084-(‡)	4	(101)
9(*)-8085-(‡)	5	(127)
9(*)-8086-(‡)	6	(152)
9(*)-8087-(‡)	7	(178)

Cross Connector Bracket

- For field connecting crossing section.
- Furnished in pairs with 3/8" hardware.
- (*) Insert **ZN** or **G**

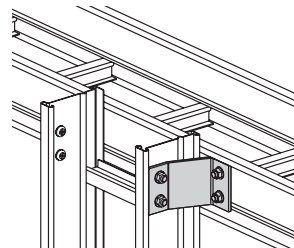
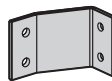

Catalog No.
9(*)-1240

● Green = Fastest shipped items ● Black = Normal lead-time items ● Red = Normally long lead-time items

All dimensions in parentheses are millimeters unless otherwise specified.

Series 2, 3, 4, & 5 Steel - Accessories

Series 2, 3, 4, & 5 Steel

Standard Tray Hardware (for field installation drill 13/32" hole)

- Finishes: [ZN] Zinc Plated ASTM B633 SC1 for pre-galvanized tray [CZ] Chromium Zinc Plated F1136-88 Grade A for hot dip galvanized tray

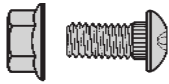

Catalog No.	Description
● RNCB 3/8" x 3/4" ZN	Ribbed Neck Carriage Bolt ASTM A307 Grade A
● SFHN 3/8"-16 ZN	Serrated Flange Hex Nut ASTM A563 Grade A
● RNCB 3/8" x 3/4" CZ	Ribbed Neck Carriage Bolt ASTM F1136-88 Grade 3
● SFHN 3/8"-16 CZ	Serrated Flange Hex Nut ASTM F1136-88 Grade A

Optional Tray Hardware (for field installation drill 13/32" hole)

- To order 316 stainless steel hardware add SS6 suffix to catalog number - Example: 9G-8004SS6

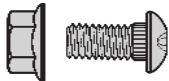

Catalog No.	Description
● RNCB 3/8" x 3/4" SS6	Ribbed Neck Carriage Bolt AISI 316 Stainless Steel
● SFHN 3/8"-16 SS6	Serrated Flange Hex Nut AISI 316 Stainless Steel

Conduit to Cable Tray Adaptor

- For easy attachment of conduit terminating at a cable tray.
- Use on aluminum or steel cable trays.

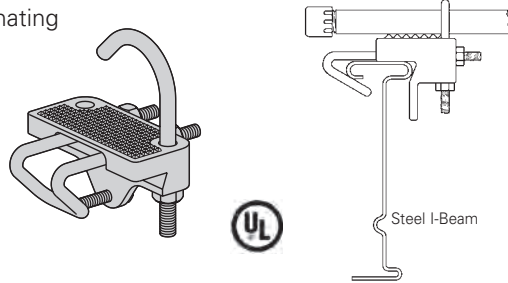

Catalog No.	Conduit Size	
	in.	mm
● 9G-1158-1/2 & 3/4	1/2, 3/4	(15, 20)
● 9G-1158-1 & 1 1/4	1, 1 1/4	(25, 32)
● 9G-1158-1 1/2 & 2	1 1/2, 2	(40, 50)
● 9G-1158-2 1/2 & 3	2 1/2, 3	(65, 80)
● 9G-1158-3 1/2 & 4	3 1/2, 4	(90, 100)

Conduit to Cable Tray Adaptor

- Assembly required.
- Mounting hardware included.
- Conduit clamps provided.
- (+) = Insert conduit size (1/2" thru 4").

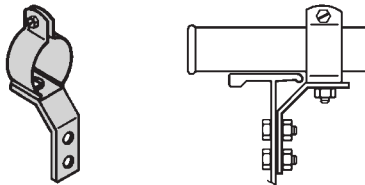

Catalog No.
● 9ZN-1150-(+)

Conduit to Cable Tray Adaptor

- Assembly required.
- Conduit clamps included.
- (+) = Insert conduit size (1/2" thru 4").

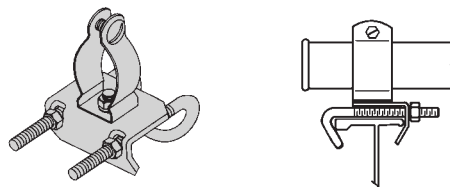

Catalog No.
● 9ZN-1155-(+)

Cable Tie (Ladder Tray)

- Nylon ties provide easy attachment of cable to ladder rungs; maximum cable O.D. is 3" (76mm).
- Cable ties are UV resistant.

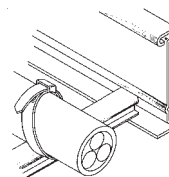
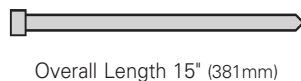

Catalog No.
● 99-2125-15

● Green = Fastest shipped items ● Black = Normal lead-time items ● Red = Normally long lead-time items

All dimensions in parentheses are millimeters unless otherwise specified.

Ladder Drop-Out

- Specially-designed Ladder Drop-Outs provide a rounded surface with 4" (101 mm) radius to protect cable as it exits from the cable tray, preventing damage to insulation. The drop-out will attach to any desired rung.

- (*) Insert **P** or **G**
- (‡) Insert tray width

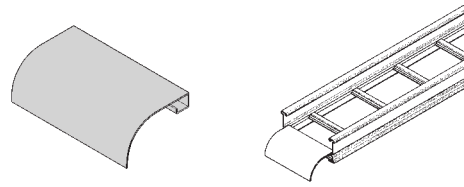

Catalog No.
● 9(*)-1104-(‡)

Trough Drop-Out

- These devices provide a rounded surface to protect cable as it exits.
- Hardware is included.
- (*) Insert **P** or **G**
- (‡) Insert tray width

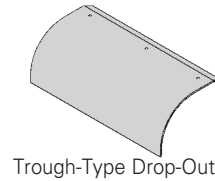

Trough-Type Drop-Out

Catalog No.
● 9(*)-1104T-(‡)

Barrier - Straight Section

- Length: Insert 120 for [120" - 10 ft.] (3.0 m) or 144 for [144" - 12 ft.] (3.6 m)
- Order catalog number based on loading depth.
- Furnished with four #10 x 1/2" plated self-drilling screws and a 99-9982 Barrier Strip Splice.
- (*) Insert **P** or **G**

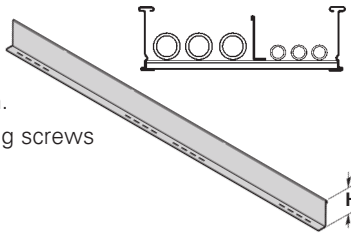

Catalog No.	Side Rail Height in. mm	Loading Depth 'H' in. mm
73(*)-Length	4 (101)	3 (76)
74(*)-Length	5 (127)	4 (101)
75(*)-Length	6 (152)	5 (127)
76(*)-Length	7 (178)	6 (152)

Barrier - Horizontal Bend

- Horizontal Bend Barriers are flexible in order to conform to any horizontal fitting radius. Can be cut to desired length.
- Standard length is 72" [6 ft.] (1.8 m) - sold individually
- Order catalog number based on loading depth.
- Furnished with three #10 x 1/2" plated self-drilling screws and a 99-9982 Barrier Strip Splice.
- (*) Insert **P** or **G**

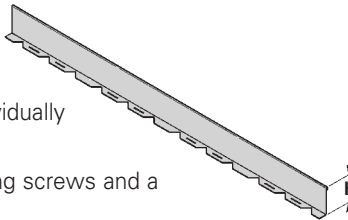

Catalog No.	Side Rail Height in. mm	Loading Depth 'H' in. mm
73(*)-90HBFL	4 (101)	3 (76)
74(*)-90HBFL	5 (127)	4 (101)
75(*)-90HBFL	6 (152)	5 (127)
76(*)-90HBFL	7 (178)	6 (152)

Barrier - Vertical Outside Bend

- Vertical Outside Bend Barriers are preformed to conform to a specific vertical outside bend fitting.
- Furnished with three #10 x 1/2" plated self-drilling screws and a 99-9982 Barrier Strip Splice.
- (*) Insert **P** or **G**
- (**) Insert 30, 45, 60 or 90 for degrees
- (†) Insert 12, 24, 36 or 48 for radius

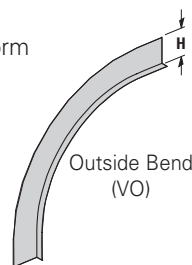

Outside Bend (VO)

Catalog No.	Side Rail Height in. mm	Loading Depth 'H' in. mm
73(*)-(**VO(†))	4 (101)	3 (76)
74(*)-(**VO(†))	5 (127)	4 (101)
75(*)-(**VO(†))	6 (152)	5 (127)
76(*)-(**VO(†))	7 (178)	6 (152)

Barrier - Vertical Inside Bend

- Vertical Inside Bend Barriers are preformed to conform to a specific vertical inside bend fitting.
- Furnished with three #10 x 1/2" plated self-drilling screws and a 99-9982 Barrier Strip Splice.
- (*) Insert **P** or **G**
- (**) Insert 30, 45, 60 or 90 for degrees
- (†) Insert 12, 24, 36 or 48 for radius

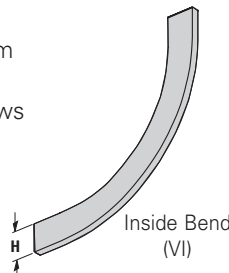

Inside Bend (VI)

Catalog No.	Side Rail Height in. mm	Loading Depth 'H' in. mm
73(*)-(**VI(†))	4 (101)	3 (76)
74(*)-(**VI(†))	5 (127)	4 (101)
75(*)-(**VI(†))	6 (152)	5 (127)
76(*)-(**VI(†))	7 (178)	6 (152)

● Green = Fastest shipped items ● Black = Normal lead-time items ● Red = Normally long lead-time items

All dimensions in parentheses are millimeters unless otherwise specified.

Series 2, 3, 4, & 5 Steel - Accessories

Series 2, 3, 4, & 5 Steel

Barrier Strip Clip

- Zinc plated steel barrier clip fastens to either aluminum or steel ladder rung.
- Furnished with one #10 x 1/2" zinc plated self-drilling screw.

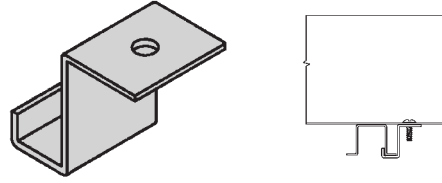

Catalog No.

● 9ZN-9002

Barrier Strip Splice

- 2.85" (72.4mm) long
- Ribbed edge for increased rigidity and grip
- Comfort edge for ease of installation
- Slotted top window with center mark for accurate placement and inspection capability
- Patent pending

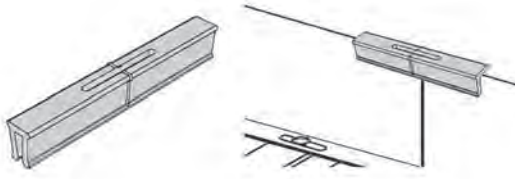

Catalog No.

● 99-9982

Bonding Jumper

Use at each expansion splice and where the cable tray is not mechanically/electrically continuous to ground. Sold individually.

- Hardware included.
- See table See table 392.60(A) on page MAN-29 for amperage ratings required to match the UL cross-sectional area of the tray.
- See tray loading chart for UL cross-sectional area.
- Bonding jumper is 14 1/2" (368mm) long.

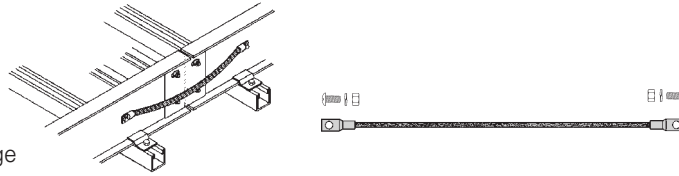

Catalog No.	Copper Wire Size	Ampacity
● 99-N1	#1	600
● 99-N6	#6	200

Grounding Clamp

B-Line series cable tray is UL® classified as to its suitability as an equipment grounding conductor. If a separate conductor for additional grounding capability is desired, we offer this clamp for bolting the conductor at least once to each cable tray section.

- Accepts #6 AWG to 250 MCM.

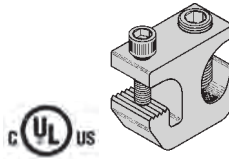

Catalog No. **Material**

● 9A-2130 Tin Plated Aluminum

Ground Wire Clamp

- Mechanically attaches grounding cables to cable tray.
- Hardware included.
- (*) Insert **ZN** or **SS4**

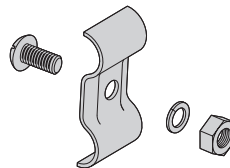

Catalog No. **Material**

9(*)-2351 #1 thru 2/0
9(*)-2352 3/0 thru 250 MCM

Thread Rod (ATR) & Rod Couplings

Loading based on safety factor 5.

Standard Finish: Zinc plated

See B-Line series Strut Systems Catalog for other sizes and finishes.

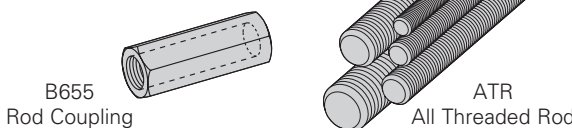

Size	Catalog No.	Available Length	Loading
All Threaded Rod			
3/8"-16	● ATR 3/8" x Length	36", 72", 120", 144"	730 lbs.
1/2"-13	● ATR 1/2" x Length	36", 72", 120", 144"	1350 lbs.
Rod Coupling			
3/8"-16	● B655-3/8"	NA	730 lbs.
1/2"-13	● B655-1/2"	NA	1350 lbs.

● Green = Fastest shipped items ● Black = Normal lead-time items ● Red = Normally long lead-time items

All dimensions in parentheses are millimeters unless otherwise specified.

Stainless Steel Cable Clamp

- Fits with series 2, 3, 4 & 5 standard steel rungs.
- Shipped flat. Field form around the cable at the time of installation.

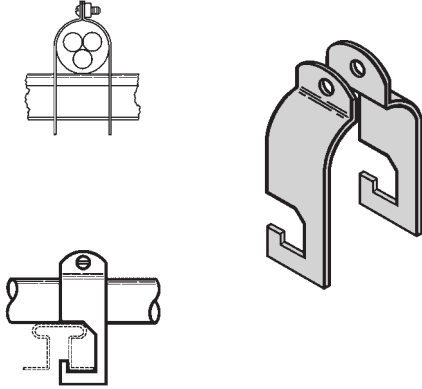

Refer to Section CF
Cable Fixing

Catalog No.	Cable Size	
	in.	mm
● 9SS4-4050	0.50 - 0.75	(13 - 19)
● 9SS4-4075	0.75 - 1.00	(19 - 25)
● 9SS4-4100	1.00 - 1.25	(25 - 32)
● 9SS4-4125	1.25 - 1.50	(32 - 38)
● 9SS4-4150	1.50 - 1.75	(38 - 45)
● 9SS4-4175	1.75 - 2.00	(45 - 51)
● 9SS4-4200	2.00 - 2.25	(51 - 57)
● 9SS4-4225	2.25 - 2.50	(57 - 64)
● 9SS4-4250	2.50 - 2.75	(64 - 70)
● 9SS4-4275	2.75 - 3.00	(70 - 76)
● 9SS4-4300	3.00 - 3.25	(76 - 82)
● 9SS4-4325	3.25 - 3.50	(82 - 89)
● 9SS4-4350	3.50 - 3.75	(89 - 95)
● 9SS4-4375	3.75 - 4.00	(95 - 100)
● 9SS4-4400	4.00 - 4.25	(100 - 106)
● 9SS4-4425	4.25 - 4.50	(106 - 113)
● 9SS4-4450	4.50 - 4.75	(113 - 121)
● 9SS4-4475	4.75 - 5.00	(121 - 125)

Hanger Rod Clamp

- For 1/2" ATR.
- Furnished in pairs.
- Order ATR and hex nuts separately.
- Two-piece "J"-hanger design.
- 1500 lbs./pair capacity safety factor 3.
- (*) Insert **ZN** or **G**

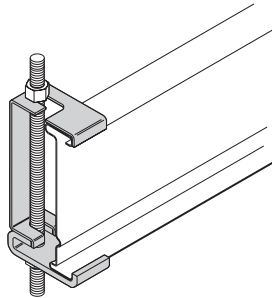

Catalog No.	Height	
	in.	mm
9(*)-5324	4	(101)
9(*)-5325	5	(127)
9(*)-5326	6	(152)
9(*)-5327	7	(178)

Cable Tray Clamp/Guide

- Features a no-twist design.
- Has four times the strength of the traditional design.
- Each side is labeled to ensure proper installation.
- Furnished in pairs, with or without hardware.
- Not recommended for vertical support.

Note: For heavy duty or vertical applications see 9(*)-1241 or 9(*)-1242 page J-20

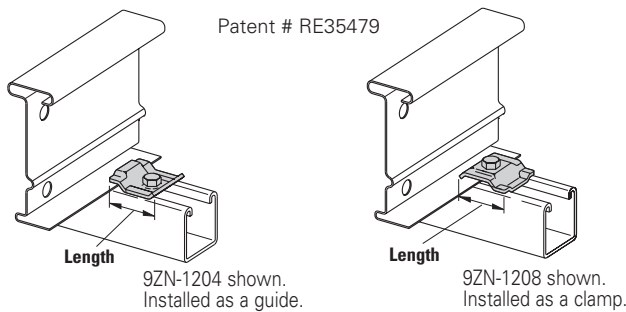

When installing this device as an expansion guide on the outside flange of *Steel Side Rail*, use the Catalog No. **B202** Square Washer in order to properly elevate the guide.

Catalog No.		Overall Length in. (mm)	Hardware Size in.	Finish
Without Hardware	With Hardware			
● 9ZN-1204	● 9ZN-1204NB	1 1/2 (38)	1/4"	G90
● 9ZN-1208	● 9ZN-1208NB	2 1/4 (57)	3/8"	G90
● 9A-1205	—	2 1/4 (57)	1/2"	Alum.
● 9G-1205	—	2 1/4 (57)	1/2"	HDGAF
● 9SS6-1205	—	2 1/4 (57)	1/2"	316SS
● 9ZN-1205	—	2 1/4 (57)	1/2"	G90

● Green = Fastest shipped items ● Black = Normal lead-time items ● Red = Normally long lead-time items

All dimensions in parentheses are millimeters unless otherwise specified.

Series 2, 3, 4, & 5 Steel - Accessories

Series 2, 3, 4, & 5 Steel

Cable Tray Clamp

- Hold-down clamps for single or double cable tray runs.
- No drilling of support I-beam or channel is required.
- Sold in pieces - two clamps are required per tray.
- Maximum beam flange thickness 1 1/8" (28.58 mm).

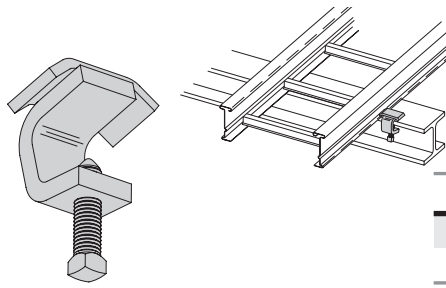

Catalog No.	Finish
● 9ZN-1249HD	Znplt
● 9G-1249HD	HDGAF

Cable Tray Guide

- Expansion guide for single or double cable tray runs.
- Guide allows for longitudinal movement of the cable tray.
- No field drilling of support I-beam or channel is required.
- Guides are required on both sides of cable tray to prevent lateral movement - can be placed on either the inside or outside flange of cable tray.
- Guides are sold in pieces - two guides are required per tray.
- Maximum flange thickness 1 1/8" (28.58 mm).

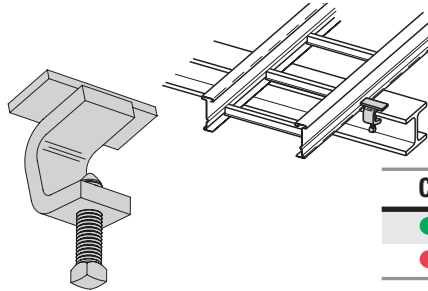

Catalog No.	Finish
● 9ZN-1249	Znplt
● 9G-1249	HDGAF

Nylon Pad

- Use for friction reduction.
- Hardness: Shore D80.
- Low friction coefficient.
- UV resistant.
- Excellent weatherability.
- UL - 94HB.

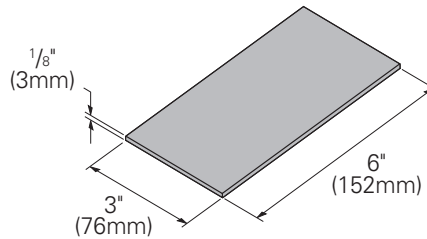

Catalog No.
● 99-PE36

Neoprene Roll

- Use for material isolation.
- 1/8" x 2" x 25' roll.
- Hardness: Shore A60.
- Good weatherability.

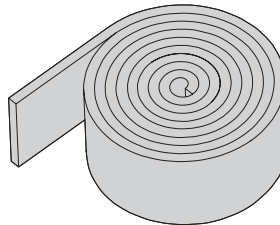

Catalog No.
● 99-NP300

DURA-BLOK™ Rooftop Support Bases with B22 Channel

- Designed as a superior rooftop support for cable tray,
- UV resistant and approved for most roofing material or other flat surfaces.
- Can be used with any of B-Line series cable tray clamps and guides.
- Ultimate Load Capacity: 1,000 lbs. (uniform load)



Catalog No.	Height x Width x Length	
	in.	(mm)
● DB10-28	5 5/8 x 6 x 28.0	(143 x 152 x 711)
● DB10-36	5 5/8 x 6 x 36.0	(143 x 152 x 914)
● DB10-42	5 5/8 x 6 x 42.0	(143 x 152 x 1067)
● DB10-50	5 5/8 x 6 x 50.0	(143 x 152 x 1270)
● DB10-60	5 5/8 x 6 x 60.0	(143 x 152 x 1524)

LEEDS credit available, base made from 100% recycled material.

General Note: Consult roofing manufacturer or engineer for roof load capacity. The weakest point may be the insulation board beneath the rubber membrane.

● Green = Fastest shipped items ● Black = Normal lead-time items ● Red = Normally long lead-time items

All dimensions in parentheses are millimeters unless otherwise specified.

Trapeze Support Kit

- Eaton's B-Line series trapeze kits provide the components required for a single trapeze support in one package. These kits are available in pre-galvanized steel with zinc-plated hardware, hot dip galvanized steel with 316 stainless steel hardware, or DURA GREEN™ painted steel with zinc-plated hardware.
- The SH channel provides the convenience of pre-punched slots, which eliminate the need for field drilling.
- The illustrated hardware is sealed in a plastic bag and boxed with the channel, which is pre-cut to the appropriate length as shown in the chart.

- Designed for use with 1/2" threaded rod. Order rod separately.

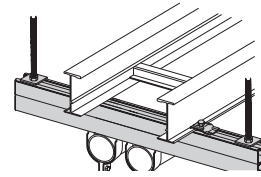
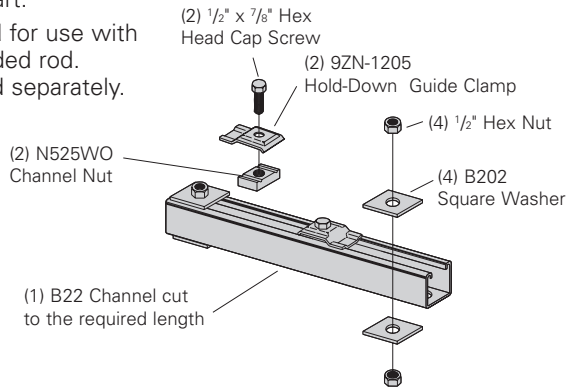

Catalog No.	Tray Width		Channel Length		Uniform Load	
	in.	mm	in.	mm	lbs	kN
● 9(*)-5506-22SH(†)	6	(152)	16	(406)	1350	(6.00)
● 9(*)-5509-22SH(†)	9	(229)	18	(457)	1250	(5.56)
● 9(*)-5512-22SH(†)	12	(305)	22	(559)	1125	(5.00)
● 9(*)-5518-22SH(†)	18	(457)	28	(711)	865	(3.85)
● 9(*)-5524-22SH(†)	24	(610)	34	(864)	700	(3.11)
● 9(*)-5530-22SH(†)	30	(762)	40	(1016)	590	(2.62)
● 9(*)-5536-22SH(†)	36	(914)	46	(1168)	510	(2.27)
● 9(*)-5542-22SH(†)	42	(1067)	52	(1321)	450	(2.00)

- (*) Insert **P** **G** or **GRN**
- (†) Insert 3/8" for 3/8" threaded rod hardware.

Safety factor of 3.0 on all loads.

Heavy Duty Trapeze Support Kit

- Eaton's B-Line series trapeze kits provide the components required for a single trapeze support in one package. These kits are available in pre-galvanized steel with zinc-plated hardware, hot dip galvanized steel with 316 stainless steel hardware, or DURA GREEN™ painted steel with zinc-plated hardware.
- The SH channel provides the convenience of pre-punched slots, which eliminates the need for field drilling.
- The illustrated hardware is sealed in a plastic bag and boxed with the channel, which is pre-cut to the appropriate length as shown in the chart.

- Designed for use with 1/2" threaded rod. Order rod separately.

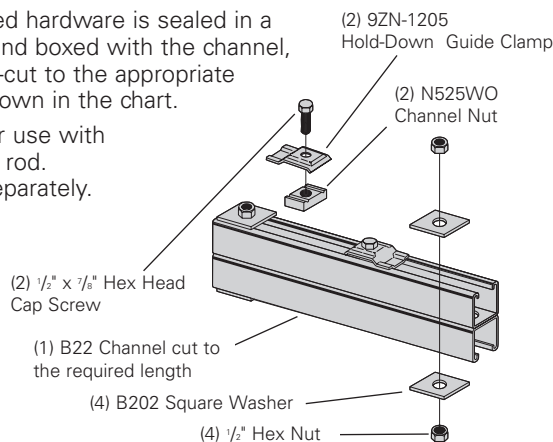

Catalog No.	Tray Width		Channel Length		Uniform Load	
	in.	mm	in.	mm	lbs	kN
● 9(*)-5506-22SHA	6	(152)	16	(406)	1350	(6.00)
● 9(*)-5509-22SHA	9	(229)	18	(457)	1350	(6.00)
● 9(*)-5512-22SHA	12	(305)	22	(559)	1350	(6.00)
● 9(*)-5518-22SHA	18	(457)	28	(711)	1350	(6.00)
● 9(*)-5524-22SHA	24	(610)	34	(864)	1350	(6.00)
● 9(*)-5530-22SHA	30	(762)	40	(1016)	1350	(6.00)
● 9(*)-5536-22SHA	36	(914)	46	(1168)	1350	(6.00)
● 9(*)-5542-22SHA	42	(1067)	52	(1321)	1350	(6.00)

- (*) Insert **P** **G** or **GRN**
- Safety factor of 3.0 on all loads.

Trapeze Hardware Kit

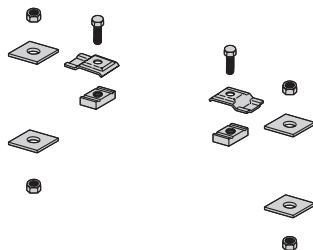

Catalog No.	● 9ZN-5500-1/2	● 9G-5500-1/2
In plastic bag	1 pr. 9ZN-1205 2 HHC Screw 1/2 x 7/8 ZN 2 N525 WO ZN 4 B202 ZN 1/2" sq washer 4 HN 1/2 ZN	1 pr. 9G-1205 2 HHC Screw 1/2 x 7/8 SS6 2 N525 WO SS6 4 B202 HDG 1/2" sq washer 4 HN 1/2 SS6

● Green = Fastest shipped items ● Black = Normal lead-time items ● Red = Normally long lead-time items

All dimensions in parentheses are millimeters unless otherwise specified.

Series 2, 3, 4, & 5 Steel - Accessories

Series 2, 3, 4, & 5 Steel

Center Hung Tray Support

- Center Hung Cable Tray Support allows cable to be laid-in from both sides.
- Eliminates costly cable pulling and field cutting of cable tray supports. Labor costs are dramatically reduced.
- Required hardware and threaded rod material for trapeze assemblies are reduced by up to 50%.
- Designed for use with 1/2" threaded rod. (Order rod separately)
- Use with all aluminum and steel cable trays through 24" width.
- Load capacity is 700 lbs. (311kN) per support. Safety factor of 3.0. Eccentric loading is not to exceed a 60% vs. 40% load differential.
- The maximum recommended unsupported span length is 144"/12 ft. (3.66 m).
- Hardware shown is furnished.
- Finish available: Zinc Plated

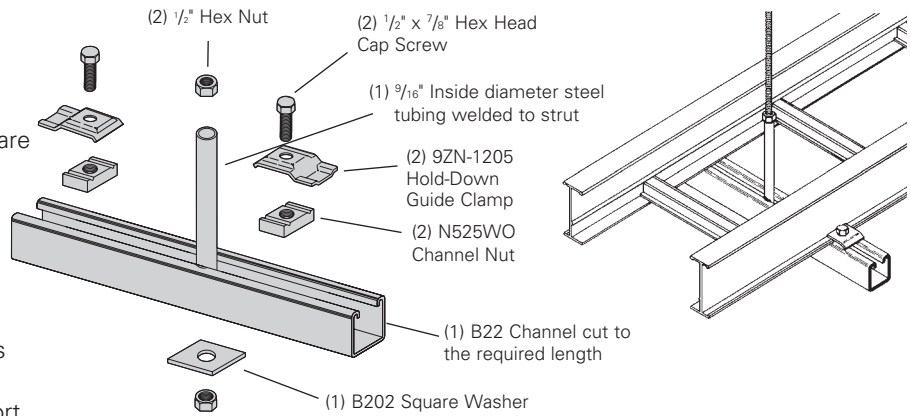

Catalog No.	Tray Width		Channel Length	
	in.	(mm)	in.	(mm)
● 9ZN-5212	6", 9", 12"	(152, 228, 305)	18"	(457)
● 9ZN-5224	18", 24"	(457, 609)	30"	(762)

Center Hung Support Hardware Kit

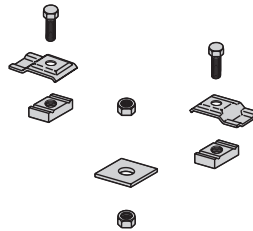

Catalog No.	● 9ZN-5200
In plastic bag	1 pr. 9ZN-1205 2 HHC Screw 1/2 x 7/8 ZN 2 N525 WO ZN 1 B202 ZN 1/2" sq washer 4 HN 1/2 ZN

Bracket (12" - 48")

- (*) Insert available finish: **ZN** **GRN** or **HDG**
- Safety Load Factor 2.5

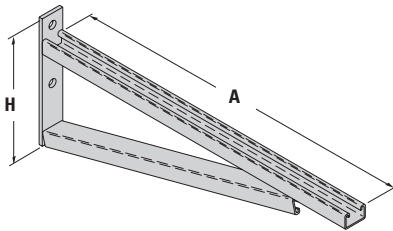

Bottom brace is B42 channel on B494-24 and smaller and B22 channel on B494-30 and larger

Catalog No.	Uniform Load lbs (kN)	Tray Width		'A'		'H'	
		in.	(mm)	in.	(mm)	in.	(mm)
● B494-12	2500 (11.12)	6 & 9	(152 & 229)	12	(305)	8 ³ / ₄	(222)
● B494-18	1700 (7.56)	12	(305)	18	(457)	8 ³ / ₄	(222)
● B494-24	1300 (5.78)	18	(457)	24	(610)	8 ³ / ₄	(222)
B494-30	1600 (7.11)	24	(610)	30	(762)	11 ¹ / ₄	(286)
B494-36	1100 (4.89)	30	(762)	36	(914)	11 ¹ / ₄	(286)
B494-42	980 (4.36)	36	(914)	42	(1067)	16	(406)
B494-48	980 (4.36)	42	(1067)	48	(1219)	16	(406)

For more dimensional data see Strut Systems catalog

Cantilever Bracket

- (*) Insert available finish: **ZN** **GRN** or **HDG**
- Safety Load Factor 2.5

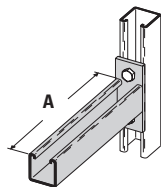

Catalog No.	Uniform Load		Tray Width		'A'	
	lbs	kN	in.	mm	in.	mm
B409-12	960	(4.27)	6 & 9	(152 & 229)	12	(305)
B409-18	640	(2.84)	12	(305)	18	(457)
B409-24	480	(2.13)	18	(457)	24	(610)

● Green = Fastest shipped items ● Black = Normal lead-time items ● Red = Normally long lead-time items

All dimensions in parentheses are millimeters unless otherwise specified.

Cantilever Bracket

- (*) Insert available finish: **ZN** **GRN** or **HDG**
- Safety Load Factor 2.5

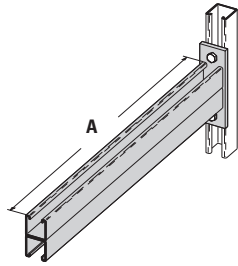

Catalog No.	Uniform Load		Tray Width		'A'	
	lbs	kN	in.	mm	in.	mm
B297-12	1660	(7.38)	6 & 9	(152 & 229)	12	(305)
B297-18	1100	(4.89)	12	(305)	18	(457)
B297-24	835	(3.71)	18	(457)	24	(610)
B297-30	665	(2.93)	24	(610)	30	(762)
B297-36	550	(2.44)	30	(762)	36	(914)
B297-42	465	(2.06)	36	(914)	42	(1067)

Underfloor Support (U-Bolts not included)

- Finishes available: **ZN**
- Safety Load Factor 2.5

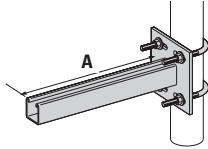

U-Bolt Size	Fits Pipe O.D.
B501-3/4	.841 - 1.050
B501-1	1.051 - 1.315
B501-1 1/4	1.316 - 1.660
B501-1 1/2	1.661 - 1.900
B501-2	1.901 - 2.375
B501-2 1/2	2.376 - 2.875

Catalog No.	Uniform Load		Tray Width		'A'	
	lbs	(kN)	in.	(mm)	in.	(mm)
B409UF-12	800	(3.56)	6 & 9	(152 & 229)	12	(305)
B409UF-21	450	(2.00)	12 & 18	(305 & 457)	21	(533)

Vertical Hanger Splice Plates

- Design load is 1500 lbs (6.67kN) per pair.
- Safety Factor of 2.5
- Furnished in pairs.
- Hole size: 9/16" (14mm) for 1/2" threaded rod.
- (*) Insert **ZN** or **G**

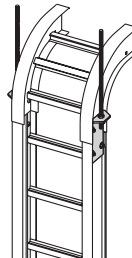
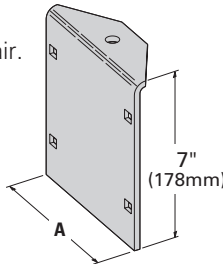

Catalog No.	Outside Cable Tray Ht.	'A'	
		in.	(mm)
● 9(*)-8224	4"	3.84	(97.54)
● 9(*)-8225	5"	4.73	(120.14)
● 9(*)-8226	6"	5.84	(148.34)
● 9(*)-8227	7"	6.84	(173.74)

Heavy Duty Hold Down Bracket

- Design load is 2000 lbs (8.89kN) per pair.
- Two bolt design.
- Sold in pairs.
- 3/8" cable tray attachment hardware provided.
- 3/8" support attachment hardware **not** provided.
- (*) Insert **ZN** or **G**
- Recommended for support of vertical trays.

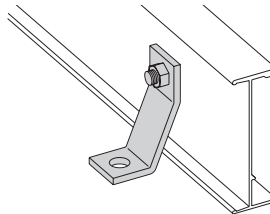

Catalog No.
9(*)-1241

Heavy Duty Hold Down Bracket

- Design load is 4000 lbs (17.79kN) per pair.
- Four bolt design.
- Sold in pairs.
- 3/8" cable tray attachment hardware provided
- 3/8" support attachment hardware **not** provided.
- (*) Insert **ZN** or **G**
- Recommended for support of vertical trays.

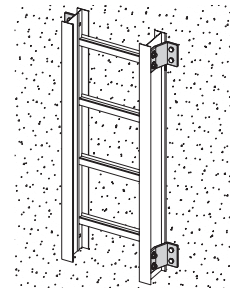
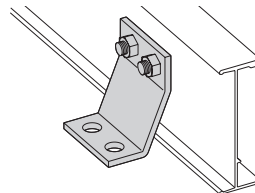

Catalog No.
9(*)-1242

Beam Clamp

- Finishes available: **ZN** **GRN** **HDG** or **SS4**
- Sold in pieces.
- Design load is 1200 lbs (5.34kN) per pair.
- Safety Load Factor 5.0.
- Order HHCS and Channel Nuts separately.

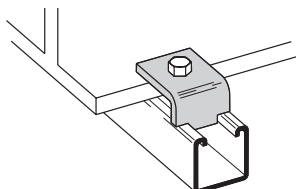

Catalog No.
B355

● Green = Fastest shipped items ● Black = Normal lead-time items ● Red = Normally long lead-time items

All dimensions in parentheses are millimeters unless otherwise specified.

Series 2, 3, 4, & 5 Steel - Accessories

Series 2, 3, 4, & 5 Steel

Beam Clamp

- Finishes available: **ZN** or **HDG**
- Sold in pieces.
- *Design load when used in pairs. Safety Load Factor 5.0

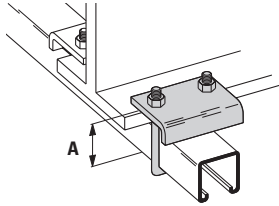

Catalog No.	Design Load lbs (kN)	'A' in. (mm)
B441-22	1200 (5.34)	3 ³ / ₈ (86)
B441-22A	1200 (5.34)	5 (127)

Beam Clamp

- Finishes available: **ZN** **GRN** or **HDG**
- Sold in pieces.
- *Design load when used in pairs. Safety Load Factor 5.0

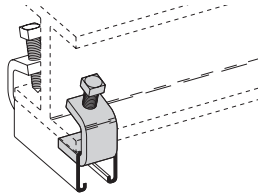

Catalog No.	B212-1/4	B212-3/8
Design Load *	600 lbs. (2.67kN)	1000 lbs. (4.45 kN)
Max. Flange Thick	3/4" (19 mm)	1 1/8" (28.6 mm)
Mat'l. Thickness	1/4" (6.3 mm)	3/8" (9.5 mm)

B305 Thru B308 & B321 Series Beam Clamps

- Finishes available: **ZN** or **HDG**
- Setscrew included.
- Safety Load Factor 5.0

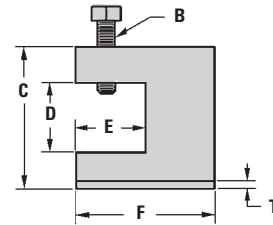
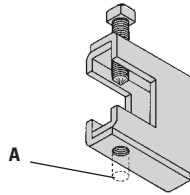

Catalog No.	Rod Size A	B	C in. (mm)	D in. (mm)	E in. (mm)	F in. (mm)	T in. (mm)	Design Load lbs (kN)
B305	3/8"-16	3/8"-16	2 ⁵ / ₁₆ (58.7)	7/8 (22.2)	1 1/8 (28.6)	2 1/2 (63.5)	11 Ga. (3.0)	600 (2.67)
B306	3/8"-16	1/2"-13	2 ⁷ / ₁₆ (61.9)	7/8 (22.2)	1 1/8 (28.6)	2 1/2 (63.5)	7 Ga. (4.5)	1100 (4.90)
B307	1/2"-13	1/2"-13	2 ⁷ / ₁₆ (61.9)	7/8 (22.2)	1 1/8 (28.6)	2 1/2 (63.5)	7 Ga. (4.5)	1100 (4.90)
B308	1/2"-13	1/2"-13	2 ⁹ / ₁₆ (65.1)	7/8 (22.2)	1 1/8 (28.6)	2 1/2 (63.5)	1/4 (6.3)	1500 (6.68)
B321-1	3/8"-16	1/2"-13	3 ⁹ / ₁₆ (90.5)	1 ¹¹ / ₁₆ (42.9)	1 ⁵ / ₈ (41.3)	3 1/4 (82.5)	1/4 (6.3)	1300 (5.79)
B321-2	1/2"-13	1/2"-13	3 ⁹ / ₁₆ (90.5)	1 ¹¹ / ₁₆ (42.9)	1 ⁵ / ₈ (41.3)	3 1/4 (82.5)	1/4 (6.3)	1400 (6.23)

Anchor Strap - for B305 thru B308 & B321 Series

- Finish available: **ZN**
- For a maximum beam thickness of 3/4" (19mm).
- For thicker beams, step up one flange width size.

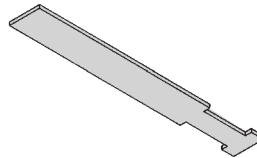

Catalog No.	Flange Width in. (mm)
B312-6	Up to 6 (Up to 152)
B312-9	6 - 9 (152 to 228)
B312-12	9 - 12 (228 to 305)

Beam Clamp

- Finish available: **ZN**
- Design Load 500 lbs. (2.22 kN)
- Safety Load Factor 5.0
- Recommended torque: 'J'-Hook Nut 125 In.-Lbs. (14.1 kN/m)
- Maximum flange thickness of 3/4" (19mm).

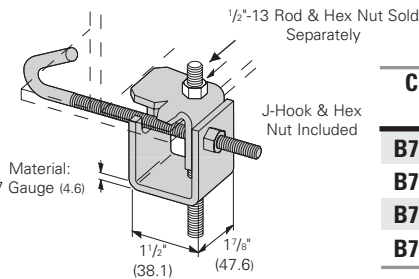

Catalog No.	For Flange Width in. (mm)	Wt./C lbs (kg)
B750-J4	3 - 6 (76.2 - 152.4)	109 (49.4)
B750-J6	5 - 9 (127.0 - 228.6)	124 (56.2)
B750-J9	8 - 12 (203.2 - 304.8)	135 (61.2)
B750-J12	11 - 15 (279.4 - 381.0)	147 (66.7)

'J'-Hook

- Finishes available: **ZN**
- Hex Nut included.

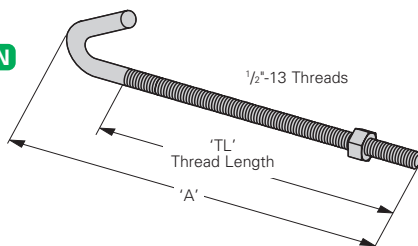

Catalog No.	'A' in. (mm)	'TL' in. (mm)	Wt./C lbs (kg)
B700-J4	8 1/2 (215.9)	5 (127.0)	44 (19.9)
B700-J6	11 1/2 (292.1)	6 (152.4)	53 (24.0)
B700-J9	12 1/4 (368.3)	6 (152.4)	63 (28.6)
B700-J12	17 1/2 (444.5)	6 (152.4)	78 (35.4)

● Green = Fastest shipped items ● Black = Normal lead-time items ● Red = Normally long lead-time items

All dimensions in parentheses are millimeters unless otherwise specified.

Covers

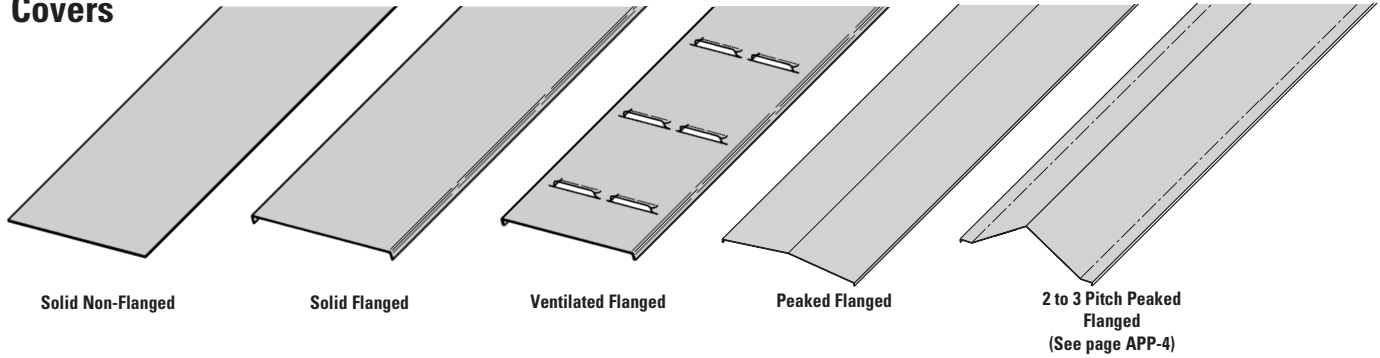

A full range of covers is available for straight sections and fittings.

Solid covers should be used when maximum enclosure of the cable is desired and no accumulation of heat is expected.

Ventilated covers provide an overhead cable shield, yet allow heat to escape.

We recommend that covers be placed on vertical cable tray runs to a height of 6 ft. (1.83 m) to 8 ft. (2.44 m) above the floor to isolate both cables and personnel. **Flanged covers** have a 1/2 in. (13 mm) flange. Cover clamps are not included with the cover and must be ordered separately. All **peaked covers** are flanged. Standard peaked covers have 1/2" peak. Special purpose peaked covers, having a 2 to 3 pitch, provide additional slope and material thickness. The 2 to 3 pitch fitting covers are of multiple piece, welded construction.

Steel Cover Part Numbering

Example: ^{Prefix} **80 2 P - 24 - 144**

Cover Type

- 80 = Solid
- 81 = Ventilated
- 82 = Peaked

Detail

- 2 = Flanged Steel (248, 258, 268 straight sections and all fittings)
- 3 = Flanged Steel (all straight sections except 248, 258, 268)
- 4 = Non-Flanged Steel (80 & 81 type only)

Material

- P = Pre-Galvanized (Not available in Type 83)
- G = HDGAF

Tray Width

- 06 = 6"
- 09 = 9"
- 12 = 12"
- 18 = 18"
- 24 = 24"
- 30 = 30"
- 36 = 36"

Item Description

For Straight Section Cover:

Pre-Galvanized Only

- 144 = 12 ft. (3.66 m)
- 120 = 10 ft. (3.05 m)

Pre-Galvanized & HDGAF

- 72 = 6 ft. (1.83 m)
- 60 = 5 ft. (1.52 m)

For fitting covers: Insert suffix of fitting to be covered. See example below.

Examples of Catalog Numbers for Fitting Covers:

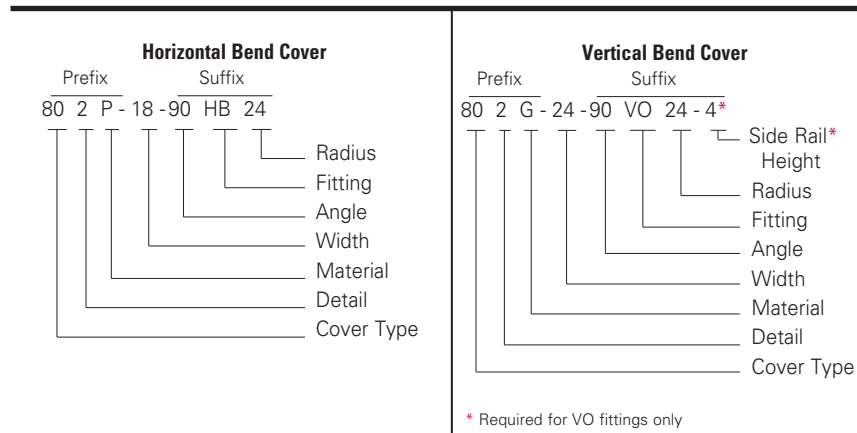

● Green = Fastest shipped items ● Black = Normal lead-time items ● Red = Normally long lead-time items

All dimensions in parentheses are millimeters unless otherwise specified.

Series 2, 3, 4, & 5 Steel - Accessories

Series 2, 3, 4, & 5 Steel

Standard Cover Clamp

- For indoor service only.
- Screw included.
- Sold per piece.
- (*) Insert **ZN** or **G**

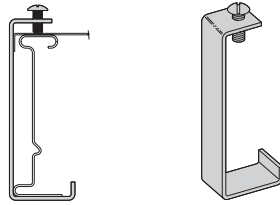

Tray Type	Catalog No.	Side Rail Height in. (mm)
Steel	9(*)-9014	4 (101)
	9(*)-9015	5 (127)
	9(*)-9016	6 (152)
	9(*)-9017	7 (78)

Combination Cover and Hold Down Clamp

- Sold per piece.
- For indoor service only.
- (*) Insert **P** or **G**

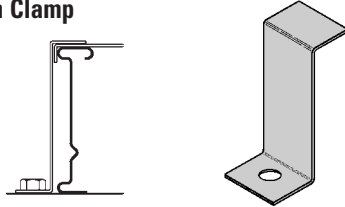

Tray Type	Catalog No.	Side Rail Height in. (mm)
Steel	9(*)-9043	4 (101)
	9(*)-9053	5 (127)
	9(*)-9063	6 (152)
	9(*)-9073	7 (78)

Raised Cover Clamp

- For indoor service only.
- For use with flanged covers only.
- † Specify gap of 1", 2", 3" or 4".

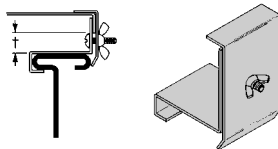

Tray Type	Catalog No.	Tray Type
●	9ZN-9114-†	Series 2 Steel Straight Section
●	9ZN-9115-†	Series 3 & 4 Steel Straight Section
●	9ZN-910†	All Steel Fittings (Also Series 1 Steel Straight Sections)

Heavy Duty Cover Clamp

- Recommended for outdoor service.
- (±) Insert tray width
- † Add P to Catalog No. for peaked cover clamp.
- (*) Insert **P** or **G**

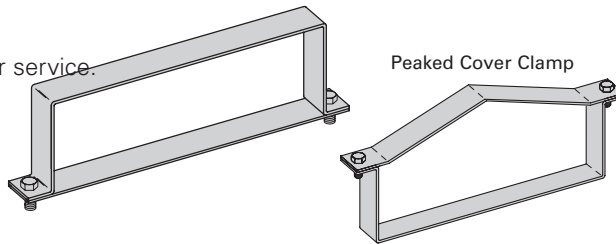

Catalog No.	Side Rail Height in. mm
9(*)-(±)-9044†	4 (101)
9(*)-(±)-9054†	5 (127)
9(*)-(±)-9064†	6 (152)
9(*)-(±)-9074†	7 (178)

Quantity of Standard Cover Clamps Required

Notes:

When using the Heavy Duty Cover Clamp, only on-half the number of clamps stated above is required.

Additional clamps may be necessary in extreme wind applications.

Straight Section 60" or 72"	4 pcs.
Straight Section 120" or 144"	6 pcs.
Horizontal/Vertical Bends	4 pcs.
Tees	6 pcs.
Crosses	8 pcs.

Cover Joint Strip

- Used to join covers
- Plastic
- Only for use on flat covers
- Color - gray.
- (±) Insert tray width

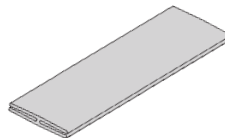

Catalog No.
● 99-9980-(±)

Cable Cleats

(see pages N-1 thru N-5) Standard

**Trefoil
Cable
Cleats**



**Single
Cable
Cleats**

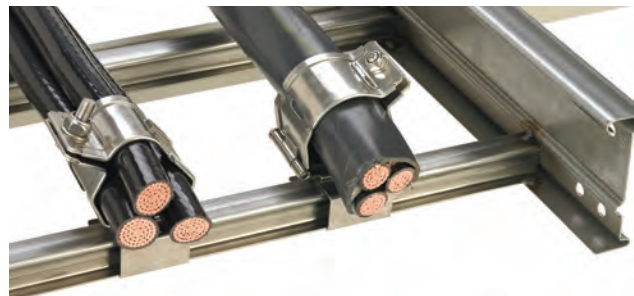

● Green = Fastest shipped items ● Black = Normal lead-time items ● Red = Normally long lead-time items

All dimensions in parentheses are millimeters unless otherwise specified.

Section 1- Acceptable Manufacturers

- 1.01 Manufacturer: Subject to compliance with these specifications, Eaton's B-Line series cable tray systems shall be as manufactured by Eaton.

Section 2- Cable Tray Sections and Components

- 2.01 General: Except as otherwise indicated, provide metal cable trays, of types, classes and sizes indicated; with splice plates, bolts, nuts and washers for connecting units. Construct units with rounded edges and smooth surfaces; in compliance with applicable standards; and with the following additional construction features. Cable tray shall be installed according to the latest revision of NEMA VE 2.
- 2.02 Pre-Galvanized Steel: Straight sections, fitting side rails, rungs, and covers shall be made from structural quality steel meeting the minimum mechanical properties and mill galvanized in accordance with ASTM A653 SS, Grade 33, coating designation G90. Hardware finish shall be electrogalvanized zinc per ASTM B633.
- 2.03 Hot Dip Galvanized Steel: All side rails, covers, splice plates, and rungs shall be made from structural quality steel meeting the minimum mechanical properties of ASTM A1011 SS, Grade 33 for 14 gauge and heavier, ASTM A1008, Grade 33 Type 2 for 16 gauge and lighter, and shall be hot dip galvanized after fabrication in accordance with ASTM A123. Mill galvanized covers are not acceptable for hot dip galvanized cable tray. Hardware finish shall be chromium zinc per ASTM F-1136-88.
- 2.04 Ladder Cable Trays shall consist of two longitudinal members (side rails) with transverse members (rungs) welded to the side rails. Rungs shall be spaced [6] [9] [12] inches apart. Rung spacing in radiused fittings shall be industry standard 9" and measured at the center of the tray's width. No portion of the rungs shall protrude below the bottom plane of the side rails. Each rung must be capable of supporting a 200 lb. concentrated load at the center of the cable tray over and above the cable load with a safety factor of 1.5.
- 2.05 Cable tray loading depth shall be [3] [4] [5] [6] inches per NEMA VE 1.
- 2.06 Straight sections shall have side rails fabricated as I-beams. Straight sections shall be supplied in standard [12 foot] [24 foot] [10 foot (3 m)] [20 foot (6 m)] lengths.
- 2.07 Cable tray widths shall be [6] [9] [12] [18] [24] [30] [36] inches or as shown on drawings.
- 2.08 Splice plates shall be manufactured of high strength steel, meeting the minimum mechanical properties of ASTM A1011 HSLAS, Grade 50, Class 1 and be secured with 8 nuts and bolts per plate. The resistance of fixed splice connections between an adjacent section of tray shall not exceed 0.00033 ohm.
- 2.09 All fittings must have a minimum radius of [12] [24] [36] [48] inches.

Section 3- Loading Capacities and Testing

- 3.01 Cable tray shall be capable of carrying a uniformly distributed load of _____ lbs./ft. on a _____ ft. support span with a safety factor of 1.5 when supported as a simple span and tested per NEMA VE 1 5.2. In addition to the uniformly distributed load the cable tray shall support 200 lbs. concentrated load at mid-point of span. Load and safety factors specified are applicable to both the side rails and rung capacities. Cable tray shall be made to manufacturing tolerances as specified by NEMA.
- 3.02 Upon request, manufacturer shall provide test reports in accordance with the latest revision of NEMA VE 1 or CSA C22.2 No. 126.

For Stainless Steel Fittings
see fittings section pages L-1 thru L-17

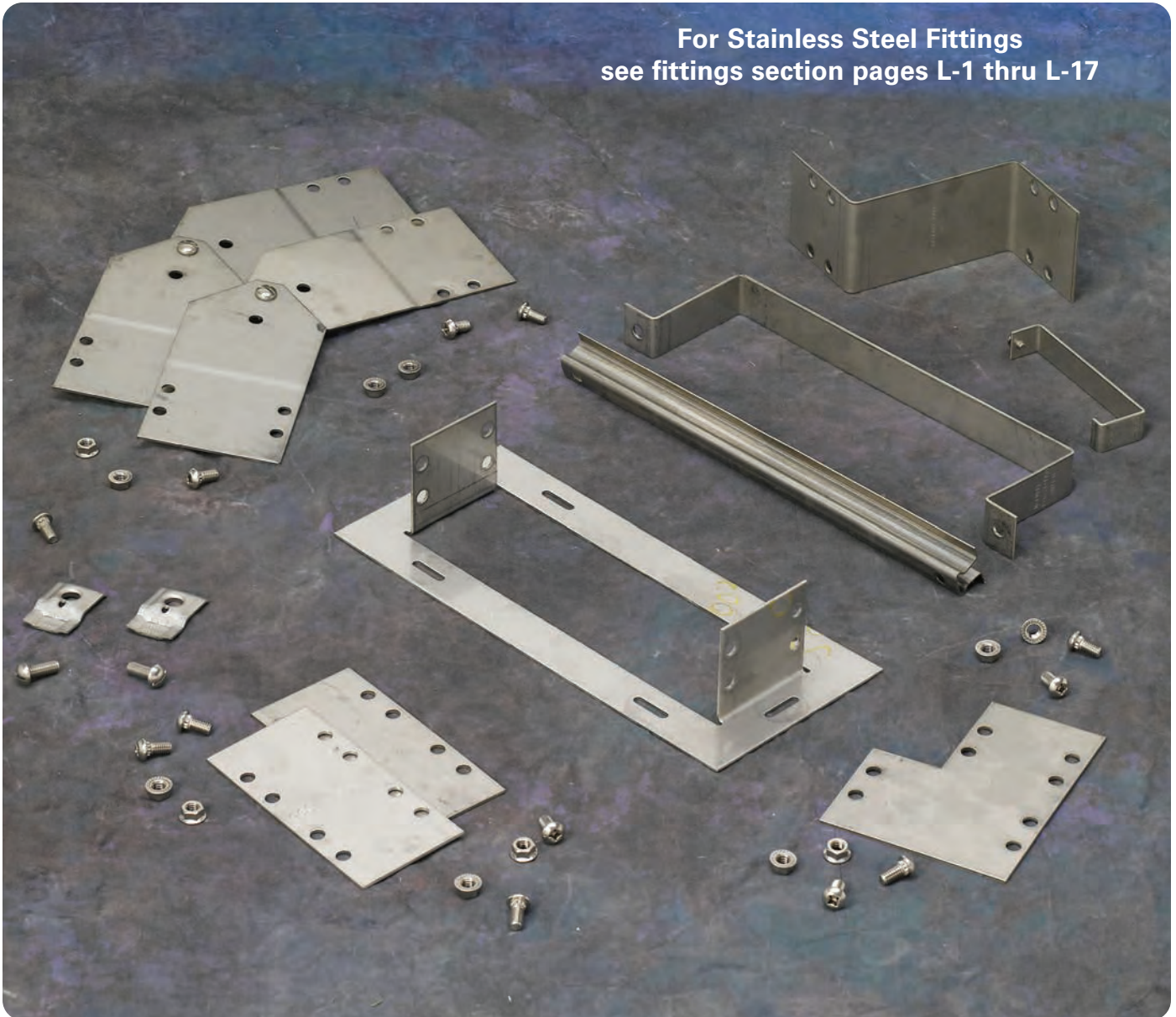

How The Service Advisor Works

We know that your time is important! That's why the color-coding system in this catalog is designed to help you select products that fit your service needs. Products are marked to indicate the typical lead time for orders of 50 pieces or less.

Customer: How do I select my straight sections, covers, or fittings so that I get the quickest turnaround?

Service Advisor: Each part of our selection chart is shown in colors. If any section of a part number is a different color, the part will typically ship with the longer lead time represented by the colors.

- Green = Fastest shipped items
- Black = Normal lead-time items
- Red = Normally long lead-time items

Example: 348SS4 09 - 12 - 144

● ● ● ●

Part will have a long lead time.

3" NEMA VE 1 Loading Depth 4" Side Rail Height

Straight Section Part Numbering

Example: ^{Prefix} **348 SS6 09 - 24 - 144**

Series

● **348**

Material

- **SS4** = 304
Stainless Steel
- **SS6** = 316
Stainless Steel

***Type**

- **SB** = Solid Bottom
- **06** = 6" rung spacing
- **09** = 9" rung spacing
- **12** = 12" rung spacing

***Width**

- **06** = 6"
- **09** = 9"
- **12** = 12"
- **18** = 18"
- **24** = 24"
- **30** = 30"
- **36** = 36"

Length

- ① **144** = 12 ft. 348
- ② **120** = 10 ft.

Notes:
① Primary Length.
② Secondary Length.
See page C-23 for explanation of lengths.

Passivation available see page C-2.

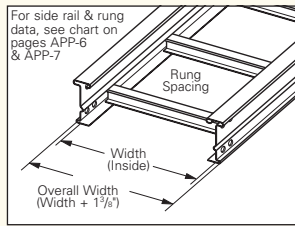

See page APP-1 for additional rung options. *Special sizes available.

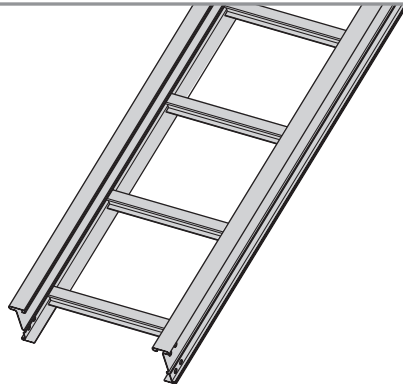

Ladder Type
(Specify Rung Spacing)

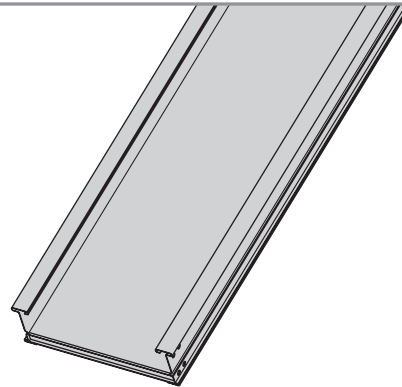

Solid Bottom

Values are based on simple beam tests per NEMA VE 1 on 36" wide cable tray rungs spaced on 12" centers. Cable trays will support without collapse a 200 lb. (90.7 kg) concentrated load over and above published loads. Published load safety factor is 1.5. To convert 1.5 safety factor to 2.0, multiply published load by 0.75. To obtain mid-span deflection, multiply a load by the deflection multiplier. Cable tray must be supported on spans shorter than or equal to the length of the cable being installed.

B-Line series	Side Rail Dimensions	NEMA, CSA & UL Classifications	Span ft	Load lbs/ft	Deflection Multiplier	Design Factors for Two Rails	Span meters	Load kg/m	Deflection Multiplier	Design Factors for Two Rails
348 SS†		NEMA: 16A, 12C CSA: C1-3m UL Cross-Sectional Area: 0.40 in ²	10	180	0.0042	Area = 0.74 in ² Sx = 0.79 in ³ Ix = 1.85 in ⁴	3.0	268	0.072	Area = 4.77 cm ² Sx = 12.95 cm ³ Ix = 77.00 cm ⁴
			12	125	0.009		3.7	186	0.148	
			14	92	0.016		4.3	137	0.275	
			16	70	0.027		4.9	105	0.469	
			18	56	0.044		5.5	83	0.752	
			20	45	0.067		6.1	67	1.145	

When cable trays are used in continuous spans, the deflection of the cable tray is reduced by as much as 50%. Design factors: Ix = Moment of Inertia, Sx = Section Modulus. † Insert 4 for 304 stainless steel or 6 for 316 stainless steel.

● Green = Fastest shipped items ● Black = Normal lead-time items ● Red = Normally long lead-time items

All dimensions in parentheses are millimeters unless otherwise specified.

4" NEMA VE 1 Loading Depth
5" Side Rail Height

Straight Section Part Numbering

Prefix
Example: **358 SS6 09 - 24 - 144**

<p>Series</p> <p>● 358</p>	<p>Material</p> <p>● SS4 = 304 Stainless Steel</p> <p>● SS6 = 316 Stainless Steel</p>	<p>*Type</p> <p>● SB = Solid Bottom</p> <p>● 06 = 6" rung spacing</p> <p>● 09 = 9" rung spacing</p> <p>● 12 = 12" rung spacing</p>	<p>*Width</p> <p>● 06 = 6"</p> <p>● 09 = 9"</p> <p>● 12 = 12"</p> <p>● 18 = 18"</p> <p>● 24 = 24"</p> <p>● 30 = 30"</p> <p>● 36 = 36"</p>	<p>Length</p> <p>● ① 144 = 12 ft. 358</p> <p>● ② 120 = 10 ft.</p> <p>Notes: ① Primary Length. ② Secondary Length.</p> <p>See page C-23 for explanation of lengths.</p> <p>Passivation available see page C-2.</p>
--	--	---	---	--

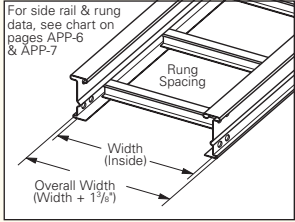

For side rail & rung data, see chart on pages APP-6 & APP-7

See page APP-1 for additional rung options. *Special sizes available.

Series 3 & 4 Stainless Steel

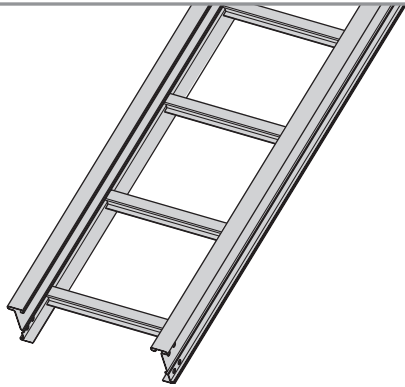

Ladder Type
(Specify Rung Spacing)

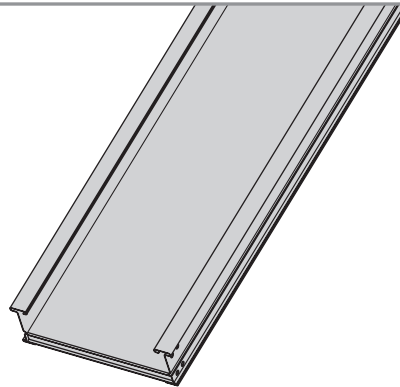

Solid Bottom

Values are based on simple beam tests per NEMA VE 1 on 36" wide cable tray rungs spaced on 12" centers. Cable trays will support without collapse a 200 lb. (90.7 kg) concentrated load over and above published loads. Published load safety factor is 1.5. To convert 1.5 safety factor to 2.0, multiply published load by 0.75. To obtain mid-span deflection, multiply a load by the deflection multiplier. Cable tray must be supported on spans shorter than or equal to the length of the cable being installed.

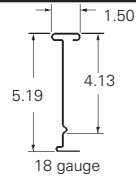
B-Line series	Side Rail Dimensions	NEMA, CSA & UL Classifications	Span ft	Load lbs/ft	Deflection Multiplier	Design Factors for Two Rails	Span meters	Load kg/m	Deflection Multiplier	Design Factors for Two Rails
358 SS†		NEMA: 20A , 16B CSA: 89kg/m 6.1m UL Cross-Sectional Area: 0.70 in ²	10	248	0.0025	Area = 0.83 in ² Sx = 1.09 in ³ Ix = 3.10 in ⁴	3.0	369	0.043	Area = 5.35 cm ² Sx = 17.86 cm ³ Ix = 129.03 cm ⁴
			12	172	0.0052		3.7	256	0.089	
			14	127	0.010		4.3	188	0.164	
			16	97	0.016		4.9	144	0.280	
			18	77	0.026		5.5	114	0.448	
			20	62	0.040		6.1	92	0.684	

When cable trays are used in continuous spans, the deflection of the cable tray is reduced by as much as 50%. Design factors: Ix = Moment of Inertia, Sx = Section Modulus. † Insert 4 for 304 stainless steel or 6 for 316 stainless steel.

● Green = Fastest shipped items ● Black = Normal lead-time items ● Red = Normally long lead-time items

All dimensions in parentheses are millimeters unless otherwise specified.

5" NEMA VE 1 Loading Depth
6" Side Rail Height

Straight Section Part Numbering

Prefix
Example: **368 SS6 09 - 24 - 144**

Series	Material	*Type	*Width	Length
● 368	● SS4 = 304 Stainless Steel	● SB = Solid Bottom	● 06 = 6"	● ① 144 = 12 ft. 368
● 464	● SS6 = 316 Stainless Steel	● 06 = 6" rung spacing	● 09 = 9"	● ② 120 = 10 ft.
		● 09 = 9" rung spacing	● 12 = 12"	● ① 144 = 12 ft. 464
		● 12 = 12" rung spacing	● 18 = 18"	● ② 120 = 10 ft.
			● 24 = 24"	
			● 30 = 30"	
			● 36 = 36"	

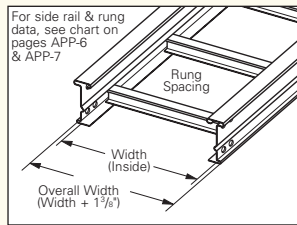

Notes:
① Primary Length.
② Secondary Length.
See page C-23 for explanation of lengths.
Passivation available see page C-2.

See page APP-1 for additional rung options. *Special sizes available.

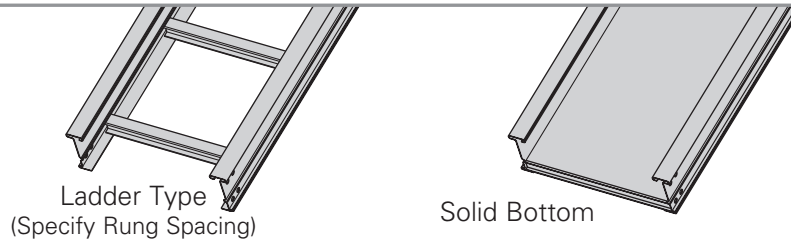

Values are based on simple beam tests per NEMA VE 1 on 36" wide cable tray rungs spaced on 12" centers. Cable trays will support without collapse a 200 lb. (90.7 kg) concentrated load over and above published loads. Published load safety factor is 1.5. To convert 1.5 safety factor to 2.0, multiply published load by 0.75. To obtain mid-span deflection, multiply a load by the deflection multiplier. Cable tray must be supported on spans shorter than or equal to the length of the cable being installed.

B-Line series	Side Rail Dimensions	NEMA, CSA & UL Classifications	Span ft	Load lbs/ft	Deflection Multiplier	Design Factors for Two Rails	Span meters	Load kg/m	Deflection Multiplier	Design Factors for Two Rails
368 SS†		NEMA: 20A, 16B CSA: D1-3m UL Cross-Sectional Area: 0.70 in ²	10	236	0.0016	Area = 0.92 in ² Sx = 1.41 in ³ Ix = 4.77 in ⁴	3.0	351	0.028	Area = 5.94 cm ² Sx = 23.11 cm ³ Ix = 198.54 cm ⁴
			12	164	0.0034		3.7	244	0.058	
			14	120	0.0062		4.3	179	0.107	
			16	92	0.011		4.9	137	0.182	
			18	73	0.017		5.5	108	0.291	
			20	59	0.026		6.1	88	0.444	

B-Line series	Side Rail Dimensions	NEMA, CSA & UL Classifications	Span ft	Load lbs/ft	Deflection Multiplier	Design Factors for Two Rails	Span meters	Load kg/m	Deflection Multiplier	Design Factors for Two Rails
464 SS†		NEMA: 20C+ CSA: E-6m UL Cross-Sectional Area: 1.00 in ²	12	342	0.002	Area = 1.49 in ² Sx = 2.28 in ³ Ix = 7.65 in ⁴	3.7	508	0.036	Area = 9.61 cm ² Sx = 37.36 cm ³ Ix = 318.42 cm ⁴
			16	192	0.007		4.9	286	0.113	
			18	152	0.011		5.5	226	0.182	
			20	123	0.016		6.1	183	0.277	
			22	102	0.024		6.7	151	0.406	
			24	85	0.034		7.3	127	0.574	

When cable trays are used in continuous spans, the deflection of the cable tray is reduced by as much as 50%. Design factors: Ix = Moment of Inertia, Sx = Section Modulus. † Insert 4 for 304 stainless steel or 6 for 316 stainless steel.

● Green = Fastest shipped items ● Black = Normal lead-time items ● Red = Normally long lead-time items

All dimensions in parentheses are millimeters unless otherwise specified.

Splice Plates

- Standard 8-hole pattern for all steel splice plates.
- Furnished in pairs with hardware.
- One pair including hardware provided with straight section. (Expansion splice quantity subtracted).
- Boxed in pairs with hardware.
- (*) Insert **SS4** or **SS6**.

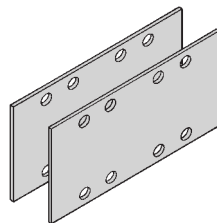

Catalog No.	Height in. mm
9(*)-8004	4 (101)
9(*)-8005	5 (127)
9(*)-8006	6 (152)

Expansion Splice Plates

- Expansion plates allow for one inch expansion or contraction of the cable tray or where expansion joints occur in the support structure.
- Furnished in pairs with hardware.
- Bonding jumpers are required on each side rail. Order separately.
- (*) Insert **SS4** or **SS6**.

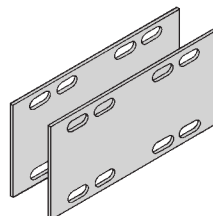

For heavy duty expansion splice plates see page APP-3.

Catalog No.	Height in. mm
9(*)-8014	4 (101)
9(*)-8015	5 (127)
9(*)-8016	6 (152)

Requires supports within 24" on both sides, per NEMA VE 2.

Universal Splice Plates

- Used to splice to existing cable tray systems.
- Furnished in pairs with hardware.
- (*) Insert **SS4** or **SS6**.

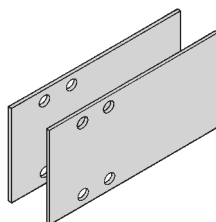

Catalog No.	Height in. mm
9(*)-8004-1/2	4 (101)
9(*)-8005-1/2	5 (127)
9(*)-8006-1/2	6 (152)

Step Down Splice Plates

- These splice plates are offered for connecting cable tray sections having side rails of different heights.
- Furnished in pairs with hardware.
- (*) Insert **SS4** or **SS6**.

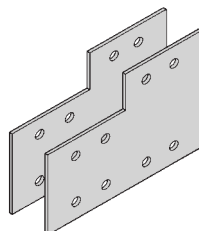

Catalog No.	Height in. mm
9(*)-8045	5 to 4 (127 to 101)
9(*)-8046	6 to 4 (152 to 101)
9(*)-8060	6 to 5 (152 to 127)

Vertical Adjustable Splice Plates

- These plates provide for changes in elevation that do not conform to standard vertical fittings.
- Furnished in pairs with hardware.
- Bonding jumpers not required.
- (*) Insert **SS4** or **SS6**.

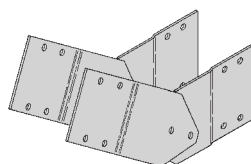

Catalog No.	Height in. mm
9(*)-8024	4 (101)
9(*)-8025	5 (127)
9(*)-8026	6 (152)

Branch Pivot Connectors

- Branch from existing cable tray runs at any point.
- Pivot to any required angle.
- UL Classified for grounding (bonding jumpers not required).
- Furnished in pairs with hardware.
- (*) Insert **SS4** or **SS6**.

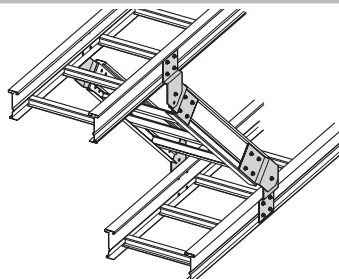

Catalog No.	Height in. mm
9(*)-8244	4 (101)
9(*)-8245	5 (127)
9(*)-8246	6 (152)

Series 3 & 4 Stainless Steel - Accessories

Horizontal Adjustable Splice Plates

- Used to adjust a cable tray run for changes in direction in a horizontal plane that do not conform to standard horizontal fittings.
- Furnished in pairs with hardware.
- Bonding jumpers **not** required.
- (*) Insert **SS4** or **SS6**.
- (X) Insert 4, 5, 6 or 7 for side rail height.

Catalog No.	Cable Tray End Cut	Thru Tray Width in. (mm)	'L' in. (mm)
9(*)-803(X)	Mitered	36 (914)	N/A (NA)
9(*)-803(X)-12	Not mitered	12 (305)	16 (406)
9(*)-803(X)-36	Not mitered	36 (914)	41 (1041)

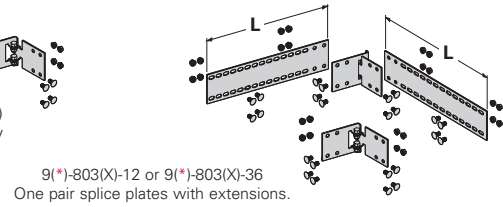
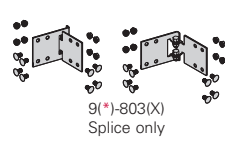

Requires supports within 24" on both sides per NEMA VE 2.

Offset Reducing Splice Plate

- This plate is used for joining cable trays having different widths. When used in pairs, they form a straight reduction. When used singly with a standard splice plate, they form an offset reduction.
- Furnished as one plate with hardware.
- (‡) Insert reduction
- (*) Insert **SS4** or **SS6**.

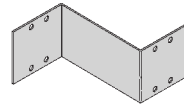

Catalog No.	Height in. mm
9(*)-8064-‡	4 (101)
9(*)-8065-‡	5 (127)
9(*)-8066-‡	6 (152)

Tray to Box Splice Plates

- Used to attach the end of a cable tray run to a distribution box or control panel.
- Furnished in pairs with hardware.
- (*) Insert **SS4** or **SS6**.

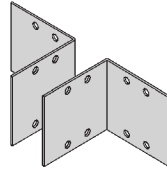

Catalog No.	Height in. mm
9(*)-8054	4 (101)
9(*)-8055	5 (127)
9(*)-8056	6 (152)

Frame Type Box Connector

- Used to attach the end of a cable tray run to a distribution cabinet or control center. Helps reinforce the box at the point of entry.
- Furnished with tray connection hardware.
- (*) Insert **SS4** or **SS6**.
- (‡) Insert tray width.

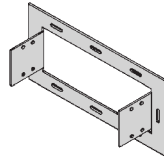

Catalog No.	Height in. mm
9(*)-8074-‡	4 (101)
9(*)-8075-‡	5 (127)
9(*)-8076-‡	6 (152)

Blind End

- This plate forms a closure for a dead end cable tray.
- Furnished as one plate with hardware.
- (*) Insert **SS4** or **SS6**.
- (‡) Insert tray width.

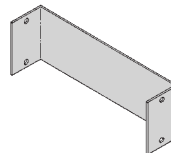

Catalog No.	Height in. mm
9(*)-8084-‡	4 (101)
9(*)-8085-‡	5 (127)
9(*)-8086-‡	6 (152)

Cross Connector Bracket

- For field connecting crossing section.
- Furnished in pairs with ³/₈" hardware.
- (*) Insert **SS4** or **SS6**.

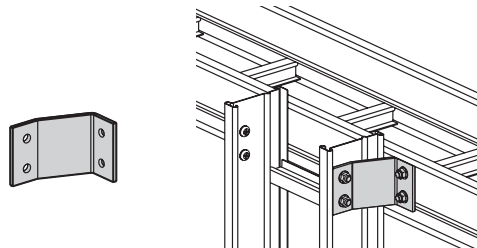

Catalog No.
9(*)-1240

Standard Tray Hardware (for field installation drill $1\frac{3}{32}$ " hole)

Catalog No.	Description
● RNCB $\frac{3}{8}$ " x $\frac{3}{4}$ " SS6	Ribbed Neck Carriage Bolt AISI 316 Stainless Steel
● SFHN $\frac{3}{8}$ "-16 SS6	Serrated Flange Hex Nut AISI 316 Stainless Steel

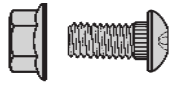

Conduit to Cable Tray Adaptor

- For easy attachment of conduit termination on a cable tray.
- Use on aluminum or steel cable trays.

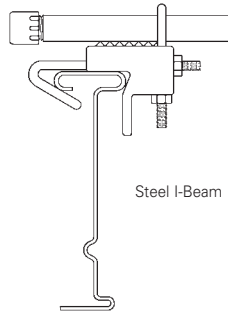
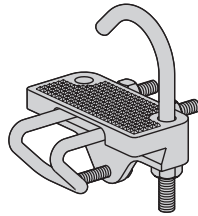

Catalog No.	Conduit Size	
	in.	mm
● 9G-1158- $\frac{1}{2}$ & $\frac{3}{4}$	$\frac{1}{2}$, $\frac{3}{4}$	(15, 20)
● 9G-1158-1 & $1\frac{1}{4}$	1, $1\frac{1}{4}$	(25, 32)
● 9G-1158- $1\frac{1}{2}$ & 2	$1\frac{1}{2}$, 2	(40, 50)
● 9G-1158- $2\frac{1}{2}$ & 3	$2\frac{1}{2}$, 3	(65, 80)
● 9G-1158- $3\frac{1}{2}$ & 4	$3\frac{1}{2}$, 4	(90, 100)

Conduit to Cable Tray Adaptor

- Assembly required.
- Mounting hardware included.
- Conduit clamps provided.
- (‡) = Insert conduit size ($\frac{1}{2}$ " thru 4").

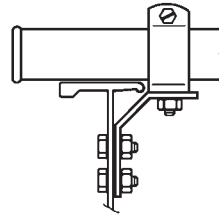

Catalog No.
● 9SS4-1150-(‡)

Conduit to Cable Tray Adaptor

- Assembly required.
- Conduit clamps included.
- (‡) = Insert conduit size ($\frac{1}{2}$ " thru 4").

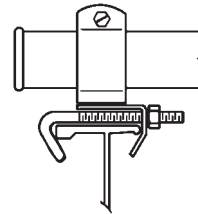
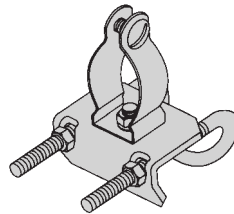

Catalog No.
● 9SS4-1155-(‡)

Cable Tie (Ladder Tray)

- Nylon ties provide easy attachment of cable to ladder rungs.
- Maximum cable O.D. is 3" (76mm).
- Cable ties are UV resistant.



Overall Length 15" (381mm)

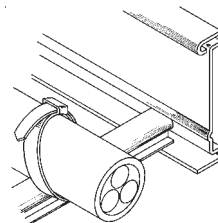

Catalog No.
● 99-2125-15

● Green = Fastest shipped items ● Black = Normal lead-time items ● Red = Normally long lead-time items

All dimensions in parentheses are millimeters unless otherwise specified.

Series 3 & 4 Stainless Steel - Accessories

Ladder Drop-Out

- Provide a rounded surface with 4" (101 mm) radius to help protect cable as it exits from the cable tray.
- Helps prevent damage to insulation.
- Attaches to any rung in the cable tray.
- (*) Insert **SS4** or **SS6**.
- (‡) Insert tray width.

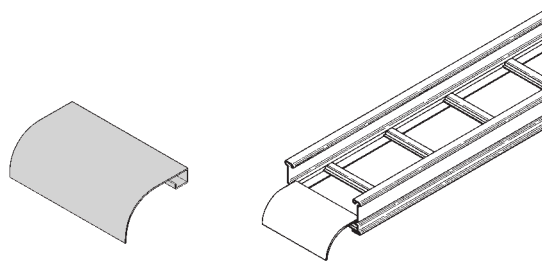

Catalog No.
● 9(*)-1104-(‡)

Barrier - Straight Section

- Length: Insert 120 for [120" - 10 ft.] (3.0 m) or 144 for [144" - 12 ft.] (3.6 m)
- Order catalog number based on loading depth.
- Furnished with four #10 x 1/2" plated self-drilling screws and a 99-9982 Barrier Strip Splice.
- (*) Insert **SS4** or **SS6**.

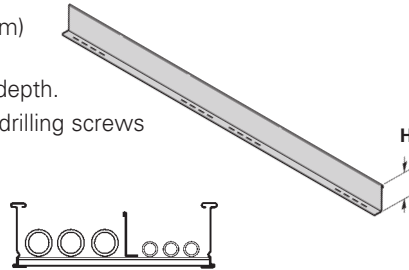

Catalog No.	Side Rail Height in. mm	Loading Depth 'H' in. mm
73(*)-Length	4 (101)	3 (76)
74(*)-Length	5 (127)	4 (101)
75(*)-Length	6 (152)	5 (127)

Barrier - Horizontal Bend

- Flexible to help conform to any horizontal fitting radius.
- Can be cut to desired length.
- Standard length is 72" [6 ft.] (1.8 m); sold individually.
- Order catalog number based on loading depth.
- Furnished with three #10 x 1/2" plated self-drilling screws and a 99-9982 Barrier Strip Splice.
- (*) Insert **SS4** or **SS6**.

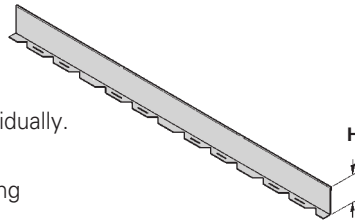

Catalog No.	Side Rail Height in. mm	Loading Depth 'H' in. mm
73(*)-90HBFL	4 (101)	3 (76)
74(*)-90HBFL	5 (127)	4 (101)
75(*)-90HBFL	6 (152)	5 (127)

Barrier - Vertical Outside Bend

- For use to help conform to a specific vertical outside bend fitting.
- Furnished with three #10 x 1/2" plated self-drilling screws and a 99-9982 Barrier Strip Splice.
- (*) Insert **SS4** or **SS6**.
- (**) Insert 30, 45, 60 or 90 for degrees.
- (‡) Insert 12, 24, 36 or 48 for radius.

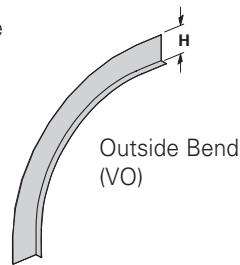

Catalog No.	Side Rail Height in. mm	Loading Depth 'H' in. mm
73(*)-(**)-VO(‡)	4 (101)	3 (76)
74(*)-(**)-VO(‡)	5 (127)	4 (101)
75(*)-(**)-VO(‡)	6 (152)	5 (127)

Barrier - Vertical Inside Bend

- Vertical Inside Bend Barriers are preformed to conform to a specific vertical inside bend fitting.
- Furnished with three #10 x 1/2" plated self-drilling screws and a 99-9982 Barrier Strip Splice.
- (*) Insert **SS4** or **SS6**.
- (**) Insert 30, 45, 60 or 90 for degrees.
- (‡) Insert 12, 24, 36 or 48 for radius.

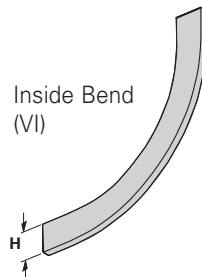

Catalog No.	Side Rail Height in. mm	Loading Depth 'H' in. mm
73(*)-(**)-VI(‡)	4 (101)	3 (76)
74(*)-(**)-VI(‡)	5 (127)	4 (101)
75(*)-(**)-VI(‡)	6 (152)	5 (127)

● Green = Fastest shipped items ● Black = Normal lead-time items ● Red = Normally long lead-time items

All dimensions in parentheses are millimeters unless otherwise specified.

Barrier Strip Clip

- Barrier clip fastens to either aluminum or steel ladder rung.
- Furnished with one #10 x 1/2" zinc plated self-drilling screw.
- (*) Insert **SS4** or **SS6**.

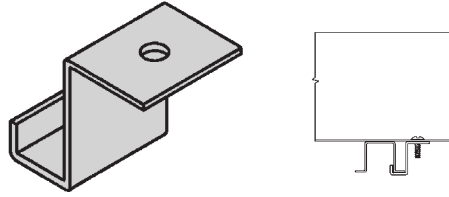

Catalog No.

9(*)-9002

Barrier Strip Splice

- 2.85" (72.4mm) long
- Ribbed edge for increased rigidity and grip
- Comfort edge for ease of installation
- Slotted top window with center mark for accurate placement and inspection capability
- Patent pending

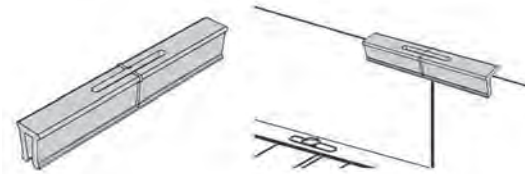

Catalog No.

● 99-9982

Thread Rod (ATR) & Rod Couplings

- Loading based on safety factor 5.
- Standard Finish: SS4 or SS6.

See B-Line series Strut Systems Catalog for other sizes and finishes.

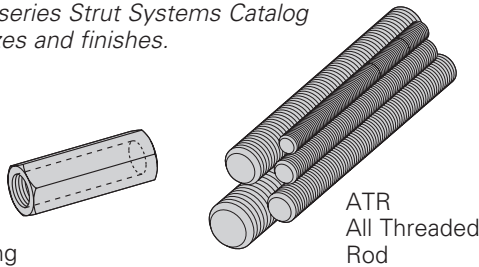

B655
Rod Coupling

ATR
All Threaded
Rod

Size	Catalog No.	Available Length	Loading
All Threaded Rod			
3/8"-16	● ATR 3/8" x Length	36", 72", 120", 144"	730 lbs.
1/2"-13	● ATR 1/2" x Length	36", 72", 120", 144"	1350 lbs.
Rod Coupling			
3/8"-16	● B655-3/8"	NA	730 lbs.
1/2"-13	● B655-1/2"	NA	1350 lbs.

Stainless Steel Cable Clamp

- Fits with series 2, 3, 4 & 5 standard steel rungs.
- See cable cleats section of the cable tray catalog for more information.
- Field form around the cable at the time of installation.
- Shipped flat.

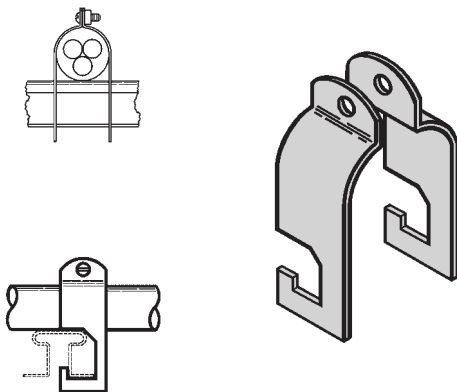

Catalog No.	Cable Size	
	in.	mm
● 9SS4-4050	0.50 - 0.75	(13 - 19)
● 9SS4-4075	0.75 - 1.00	(19 - 25)
● 9SS4-4100	1.00 - 1.25	(25 - 32)
● 9SS4-4125	1.25 - 1.50	(32 - 38)
● 9SS4-4150	1.50 - 1.75	(38 - 45)
● 9SS4-4175	1.75 - 2.00	(45 - 51)
● 9SS4-4200	2.00 - 2.25	(51 - 57)
● 9SS4-4225	2.25 - 2.50	(57 - 64)
● 9SS4-4250	2.50 - 2.75	(64 - 70)
● 9SS4-4275	2.75 - 3.00	(70 - 76)
● 9SS4-4300	3.00 - 3.25	(76 - 82)
● 9SS4-4325	3.25 - 3.50	(82 - 89)
● 9SS4-4350	3.50 - 3.75	(89 - 95)
● 9SS4-4375	3.75 - 4.00	(95 - 100)
● 9SS4-4400	4.00 - 4.25	(100 - 106)
● 9SS4-4425	4.25 - 4.50	(106 - 113)
● 9SS4-4450	4.50 - 4.75	(113 - 121)
● 9SS4-4475	4.75 - 5.00	(121 - 125)

● Green = Fastest shipped items ● Black = Normal lead-time items ● Red = Normally long lead-time items

All dimensions in parentheses are millimeters unless otherwise specified.

Series 3 & 4 Stainless Steel - Accessories

Cable Tray Clamp/Guide

- Features a no-twist design.
- Has four times the strength of the traditional design.
- Each side is labeled to ensure proper installation.
- Furnished in pairs without hardware.
- Not recommended for vertical support.

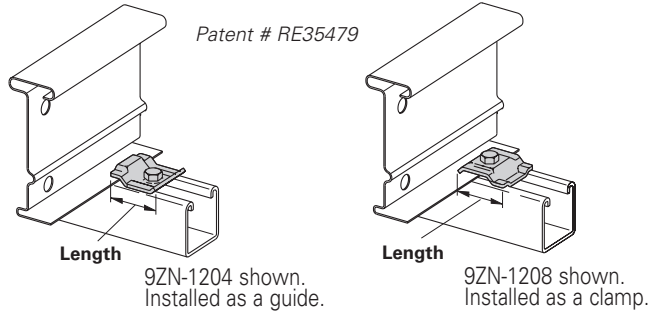

Catalog No.		Overall Length in. (mm)	Hardware Size in.	Finish
Without Hardware	With Hardware			
● 9SS6-1205	● 9SS6-1205NB	2 1/4 (57)	1/2"	316SS

When installing this device as an expansion guide on the outside flange of *Steel Side Rail*, use the Catalog No. **B202** Square Washer in order to properly elevate the guide.

Note: For heavy duty or vertical applications see 9(*)-1241 or 9(*)-1242 page K-15

Vertical Hanger Splice Plates

- Design load is 1500 lbs (6.67kN) per pair.
- Safety Factor of 2.5.
- Furnished in pairs.
- Hole size: 9/16" (14mm) for 1/2" threaded rod.
- (*) Insert **SS4** or **SS6**.

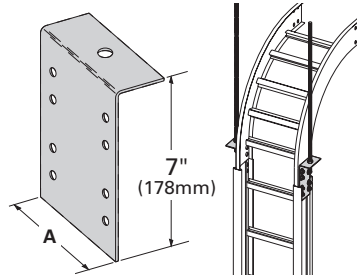

Catalog No.	Outside Cable Tray Ht.	'A' in. (mm)
9(*)-8224	4"	3.84 (97.54)
9(*)-8225	5"	4.73 (120.14)
9(*)-8226	6"	5.84 (148.34)
9(*)-8227	7"	6.84 (173.74)

Cable Tray Clamp

- Hold-down clamps for single or double cable tray runs.
- No drilling of support I-beam or channel is required.
- Sold in pieces; two clamps are required per tray.
- Maximum beam flange thickness 1 1/8" (28.58 mm).
- (*) Insert **SS4** or **SS6**.

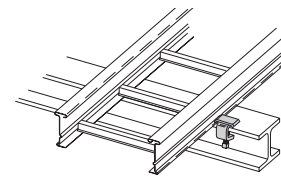
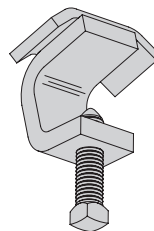

Catalog No.	Finish
● 9SS4-1249HD	304SS
● 9SS6-1249HD	316SS

Cable Tray Guide

- Expansion guide for single or double cable tray runs.
- Guide allows for longitudinal movement of the cable tray.
- No field drilling of support I-beam or channel is required.
- Guides are required on both sides of cable tray to prevent lateral movement; can be placed on either the inside or outside flange of cable tray.
- Guides are sold in pieces - two guides are required per tray.
- Maximum flange thickness 1 1/8" (28.58 mm).
- (*) Insert **SS4** or **SS6**.

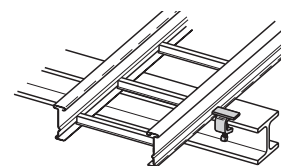
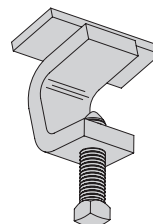

Catalog No.	Finish
● 9SS4-1249	304SS
● 9SS6-1249	316SS

● Green = Fastest shipped items ● Black = Normal lead-time items ● Red = Normally long lead-time items

All dimensions in parentheses are millimeters unless otherwise specified.

Nylon Pad

- Use for friction reduction.
- Hardness: Shore D80.
- Low friction coefficient.
- UV resistant.
- Excellent weatherability.
- UL - 94HB.

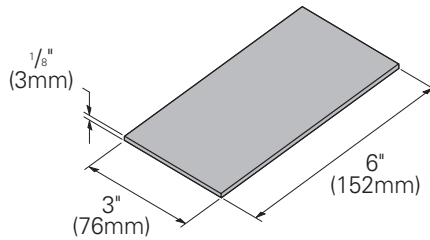

Catalog No.

● 99-PE36

Neoprene Roll

- Use for material isolation.
- 1/8" x 2" x 25' roll.
- Hardness: Shore A60.
- Good weatherability.

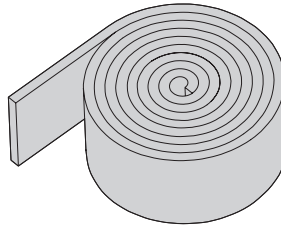

Catalog No.

● 99-NP300

DURA-BLOK™ Rooftop Support Bases with B22 Channel

- Designed as a superior rooftop support for cable tray.
- UV resistant and approved for most roofing material or other flat surfaces.
- Can be used with any of B-Line series cable tray clamps and guides.
- Ultimate Load Capacity: 1,000 lbs. (uniform load).

Catalog No.	Height x Width x Length	
	in.	(mm)
● DB10-28	5 ⁵ / ₈ x 6 x 28.0	(143 x 152 x 711)
● DB10-36	5 ⁵ / ₈ x 6 x 36.0	(143 x 152 x 914)
● DB10-42	5 ⁵ / ₈ x 6 x 42.0	(143 x 152 x 1067)
● DB10-50	5 ⁵ / ₈ x 6 x 50.0	(143 x 152 x 1270)
● DB10-60	5 ⁵ / ₈ x 6 x 60.0	(143 x 152 x 1524)



LEEDS credit available, base made from 100% recycled material.

General Note: Consult roofing manufacturer or engineer for roof load capacity. The weakest point may be the insulation board beneath the rubber membrane.



● Green = Fastest shipped items ● Black = Normal lead-time items ● Red = Normally long lead-time items

All dimensions in parentheses are millimeters unless otherwise specified.

Series 3 & 4 Stainless Steel - Accessories

Trapeze Support Kit

- Kit includes components for a single trapeze support in one package.
- The SH channel provides the convenience of pre-punched slots, which helps eliminate the need for field drilling.
- The illustrated hardware is (shown below) sealed in a plastic bag and boxed with the channel, which is pre-cut to the appropriate length as shown in the chart.
- Designed for use with 1/2" threaded rod. **Order rod separately.**
- Available in type 304 or Type 316 stainless steel.

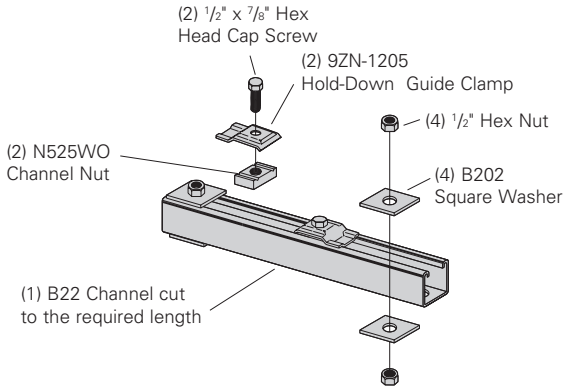
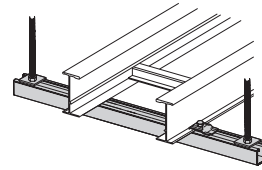

Catalog No.	Tray Width		Channel Length		Uniform Load	
	in.	mm	in.	mm	lbs	kN
● 9(*)-5506-22SH(†)	6	(152)	16	(406)	1350	(6.00)
● 9(*)-5509-22SH(†)	9	(229)	18	(457)	1250	(5.56)
● 9(*)-5512-22SH(†)	12	(305)	22	(559)	1125	(5.00)
● 9(*)-5518-22SH(†)	18	(457)	28	(711)	865	(3.85)
● 9(*)-5524-22SH(†)	24	(610)	34	(864)	700	(3.11)
● 9(*)-5530-22SH(†)	30	(762)	40	(1016)	590	(2.62)
● 9(*)-5536-22SH(†)	36	(914)	46	(1168)	510	(2.27)
● 9(*)-5542-22SH(†)	42	(1067)	52	(1321)	450	(2.00)

- (*) Insert **SS4** or **SS6**.
 - (†) Insert 3/8" for 3/8" threaded rod hardware.
- Safety factor of 3.0 on all loads.

Heavy Duty Trapeze Support Kit

- Kit includes components for a single trapeze support in one package.
- The SH channel provides the convenience of pre-punched slots, which helps eliminates the need for field drilling.
- The illustrated hardware (shown below) is sealed in a plastic bag and boxed with the channel, which is pre-cut to the appropriate length as shown in the chart.
- Designed for use with 1/2" threaded rod. **Order rod separately.**
- Available in type 304 or Type 316 stainless steel.

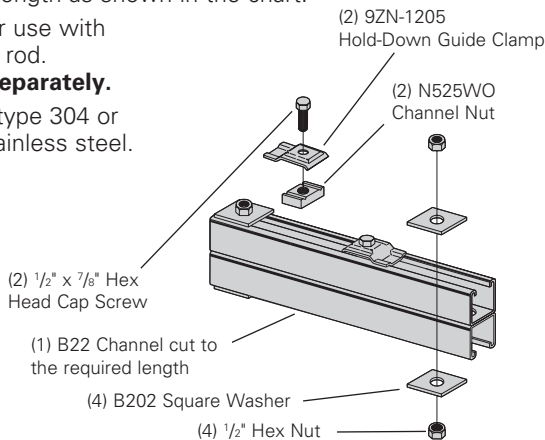

Catalog No.	Tray Width		Channel Length		Uniform Load	
	in.	mm	in.	mm	lbs	kN
● 9(*)-5506-22SHA	6	(152)	16	(406)	1350	(6.00)
● 9(*)-5509-22SHA	9	(229)	18	(457)	1350	(6.00)
● 9(*)-5512-22SHA	12	(305)	22	(559)	1350	(6.00)
● 9(*)-5518-22SHA	18	(457)	28	(711)	1350	(6.00)
● 9(*)-5524-22SHA	24	(610)	34	(864)	1350	(6.00)
● 9(*)-5530-22SHA	30	(762)	40	(1016)	1350	(6.00)
● 9(*)-5536-22SHA	36	(914)	46	(1168)	1350	(6.00)
● 9(*)-5542-22SHA	42	(1067)	52	(1321)	1350	(6.00)

- (*) Insert **SS4** or **SS6**.
- Safety factor of 3.0 on all loads.

Trapeze Hardware Kit

- Hardware shipped in plastic bag.

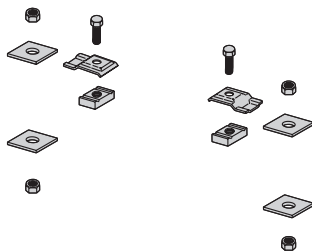

Description	Catalog No.	
	● 9SS4-5500-1/2	● 9SS6-5500-1/2
Items included in the kit.	1 pr. 9SS6-1205	1 pr. SS6-1205
	2 HHC Screw 1/2 x 7/8 SS4	2 HHC Screw 1/2 x 7/8 SS6
	2 N525 WO SS6	2 N525 WO SS6
	4 B202 SS4 1/2" sq washer	4 B202 SS6 1/2" sq washer
	4 HN 1/2 SS4	4 HN 1/2" SS6

● Green = Fastest shipped items ● Black = Normal lead-time items ● Red = Normally long lead-time items

All dimensions in parentheses are millimeters unless otherwise specified.

Bracket (12"- 42")

- Bottom brace is B42 channel on B494-24 and smaller and B22 channel on B494-30 and larger.
- For more dimensional data see Strut Systems catalog.
- Safety Load Factor 2.5.
- (*) Insert available finish: **SS4** or **SS6**.
- Safety Load Factor 2.5.

Catalog No.	Uniform Load		Tray Width		'A'		'H'	
	lbs	(kN)	in.	(mm)	in.	(mm)	in.	(mm)
B494-12	2500	(11.12)	6 & 9	(152 & 229)	12	(305)	8 ³ / ₄	(222)
B494-18	1700	(7.56)	12	(305)	18	(457)	8 ³ / ₄	(222)
B494-24	1300	(5.78)	18	(457)	24	(610)	8 ³ / ₄	(222)
B494-30	1600	(7.11)	24	(610)	30	(762)	11 ¹ / ₄	(286)
B494-36	1100	(4.89)	30	(762)	36	(914)	11 ¹ / ₄	(286)
B494-42	980	(4.36)	36	(914)	42	(1067)	16	(406)
B494-48	980	(4.36)	42	(1067)	48	(1219)	16	(406)

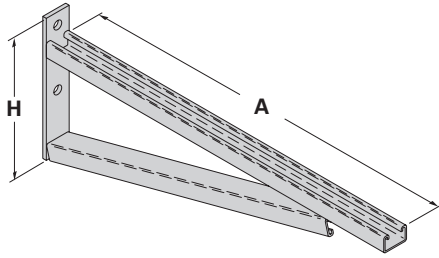

Cantilever Bracket

- (*) Insert available finish: **SS4** or **SS6**.
- Safety Load Factor 2.5.

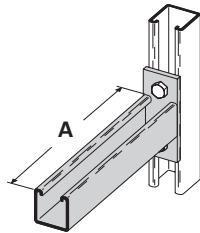

Catalog No.	Uniform Load		Tray Width		'A'	
	lbs	kN	in.	mm	in.	mm
B409-12(*)	960	(4.27)	6 & 9	(152 & 229)	12	(305)
B409-18(*)	640	(2.84)	12	(305)	18	(457)
B409-24(*)	480	(2.13)	18	(457)	24	(610)

Cantilever Bracket

- (*) Insert available finish: **SS4** or **SS6**.
- Safety Load Factor 2.5.

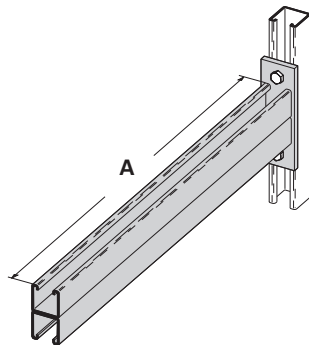

Catalog No.	Uniform Load		Tray Width		'A'	
	lbs	kN	in.	mm	in.	mm
B297-12(*)	1660	(7.38)	6 & 9	(152 & 229)	12	(305)
B297-18(*)	1100	(4.89)	12	(305)	18	(457)
B297-24(*)	835	(3.71)	18	(457)	24	(610)
B297-30(*)	665	(2.93)	24	(610)	30	(762)
B297-36(*)	550	(2.44)	30	(762)	36	(914)
B297-42(*)	465	(2.06)	36	(914)	42	(1067)

● Green = Fastest shipped items ● Black = Normal lead-time items ● Red = Normally long lead-time items

All dimensions in parentheses are millimeters unless otherwise specified.

Series 3 & 4 Stainless Steel - Accessories

Series 3 & 4 Stainless Steel

Heavy Duty Hold Down Bracket

- Design load is 2000 lbs (8.89kN) per pair.
- Two bolt design.
- Sold in pairs.
- 3/8" cable tray attachment hardware provided.
- 3/8" support attachment hardware **not** provided.
- Recommended for support of vertical trays.
- (*) Insert **SS4** or **SS6**.

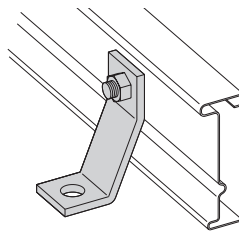

Catalog No.
9(*)-1241

Heavy Duty Hold Down Bracket

- Design load is 4000 lbs (17.79kN) per pair.
- Four bolt design.
- Sold in pairs.
- 3/8" cable tray attachment hardware provided
- 3/8" support attachment hardware **not** provided.
- Recommended for support of vertical trays.
- (*) Insert **SS4** or **SS6**.

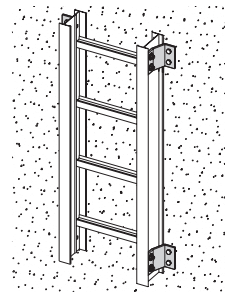
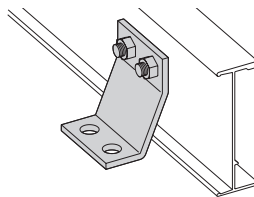

Catalog No.
9(*)-1242

Beam Clamp

- Sold in pieces.
- Design load is 1200 lbs (5.34kN) per pair.
- Safety Load Factor 5.0.
- Order HHCS and Channel Nuts separately.
- Finishes available: **SS4**.

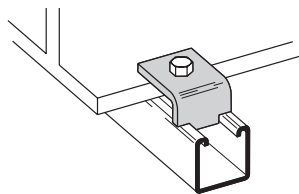

Catalog No.
B355SS4

Beam Clamp

- Sold in pieces.
- (*) Insert **SS4** or **SS6**.

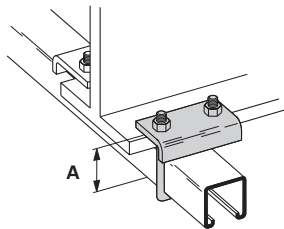

Catalog No.	Design Load lbs (kN)	'A' in. (mm)
B441-22(*)	1200 (5.34)	3 ³ / ₈ (86)
B441-22A(*)	1200 (5.34)	5 (127)

*Design load when used in pairs.
Safety Load Factor 5.0.

Beam Clamp

- Sold in pieces.
- Finishes available: **SS4**.

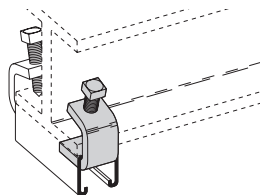

Description	Catalog No.	
	B212-1/4SS4	B212-3/8SS6
Design Load *	600 lbs. (2.67kN)	1000 lbs. (4.45 kN)
Max. Flange Thick	3/4" (19 mm)	1 1/8" (28.6 mm)
Mat'l. Thickness	1/4" (6.3 mm)	3/8" (9.5 mm)

*Design load when used in pairs.
Safety Load Factor 5.0.

● Green = Fastest shipped items ● Black = Normal lead-time items ● Red = Normally long lead-time items

All dimensions in parentheses are millimeters unless otherwise specified.

Covers

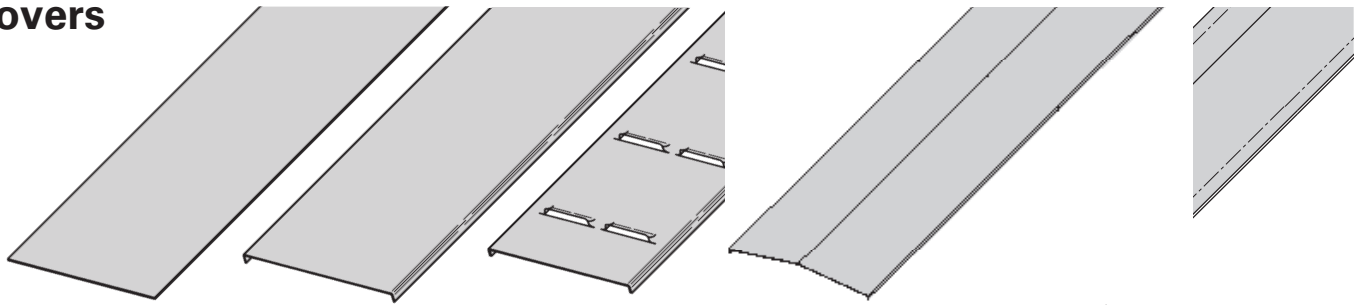

Solid Non-Flanged

Solid Flanged

Ventilated Flanged

Peaked Flanged

2 to 3 Pitch Peaked Flanged
(See page APP-4)

A full range of covers is available for straight sections and fittings.

Solid covers should be used when maximum enclosure of the cable is desired and no accumulation of heat is expected.

Ventilated covers provide an overhead cable shield yet allow heat to escape.

We recommend that covers be placed on vertical cable tray runs to a height of 6 ft. (1.83 m) to 8 ft. (2.44 m) above the floor to isolate both cables and personnel. **Flanged covers** have a 1/2 in. (13 mm) flange. Cover clamps are not included with the cover and must be ordered separately. All **peaked covers** are flanged. Standard peaked covers have 1/2" peak. Special purpose peaked covers, having a 2 to 3 pitch, provide additional slope and material thickness. The 2 to 3 pitch fitting covers are of multiple piece, welded construction.

Series 3 & 4 Stainless Steel

Steel Cover Part Numbering

Example: **80 2 SS4 - 24 - 144**

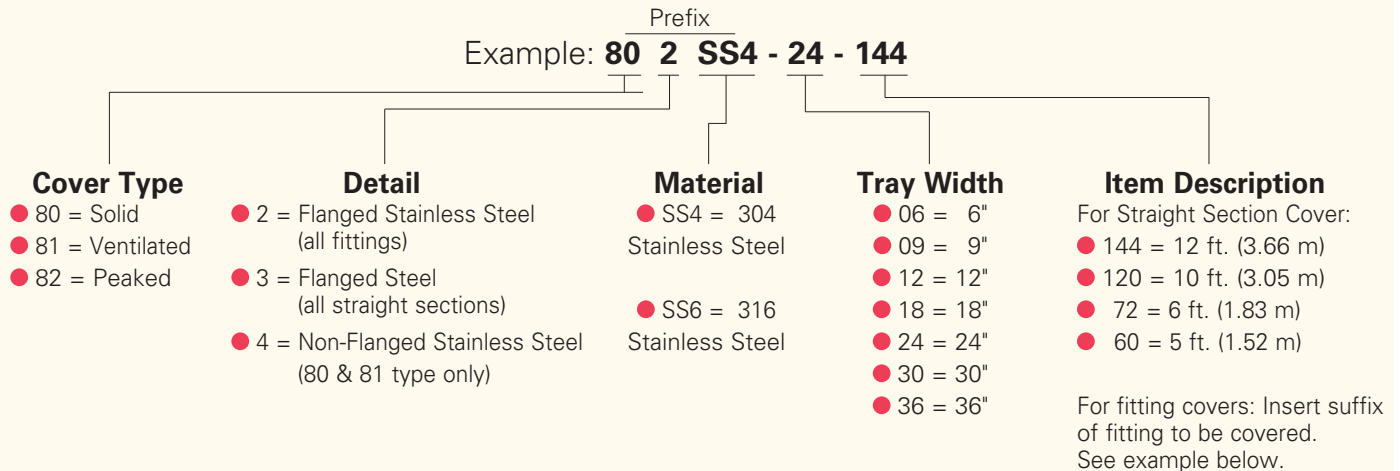

Examples of Catalog Numbers for Fitting Covers:

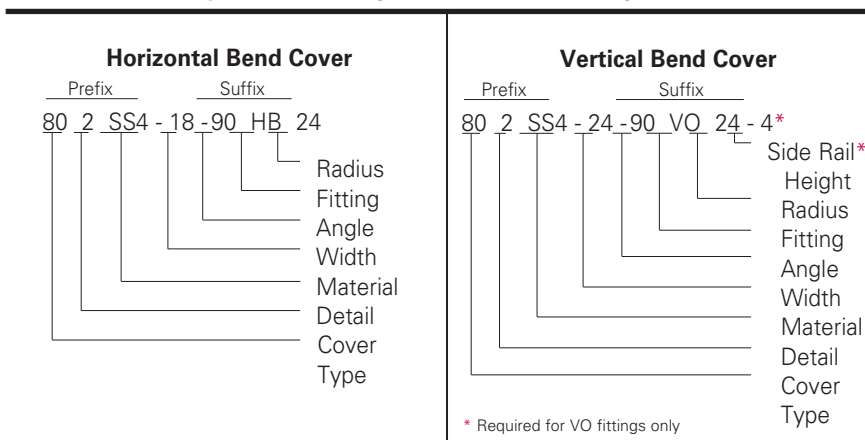

● Green = Fastest shipped items ● Black = Normal lead-time items ● Red = Normally long lead-time items

All dimensions in parentheses are millimeters unless otherwise specified.

Series 3 & 4 Stainless Steel - Accessories

Standard Cover Clamp

- For indoor service only.
- Screw included.
- Sold per piece.

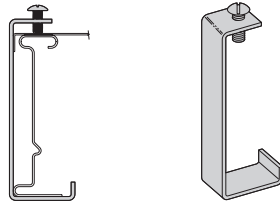

Tray Type	Catalog No.	Side Rail Height in. (mm)
Stainless Steel	9SS6-9014	4 (101)
	9SS6-9015	5 (127)
	9SS6-9016	6 (152)

Combination Cover and Hold Down Clamp

- Sold per piece.
- For indoor service only.
- (*) Insert **SS4** or **SS6**.

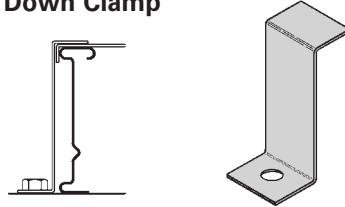

Tray Type	Catalog No.	Side Rail Height in. (mm)
Stainless Steel	9(*)-9043	4 (101)
	9(*)-9053	5 (127)
	9(*)-9063	6 (152)

Raised Cover Clamp

- For indoor service only.
- For use with flanged covers only.
- † Specify gap of 1", 2", 3" or 4".
- (*) Insert **SS4** or **SS6**.

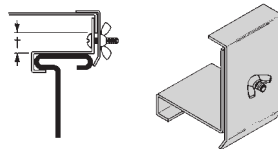

Tray Type	Catalog No.	Tray Type
● 9(*)-9115-†	Series 3 & 4 Steel Straight Section	
● 9(*)-910†	All Steel Fittings (Also Series 1 Steel Straight Sections)	

Heavy Duty Cover Clamp

- Recommended for outdoor service.
- (±) Insert tray width
- † Add P to Catalog No. for peaked cover clamp.
- (*) Insert **SS4** or **SS6**.

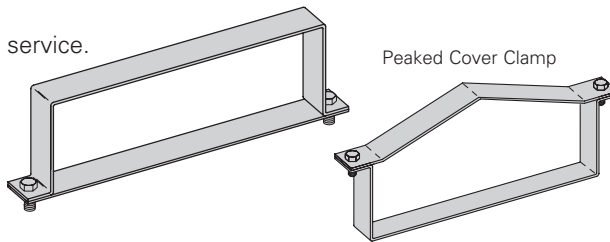

Catalog No.	Side Rail Height in. mm
9(*)-(±)-9044†	4 (101)
9(*)-(±)-9054†	5 (127)
9(*)-(±)-9064†	6 (152)

Quantity of Standard Cover Clamps Required

Notes:

When using the Heavy Duty Cover Clamp, only on-half the number of clamps stated above is required.

Additional clamps may be necessary in extreme wind applications.

Straight Section 60" or 72"	4 pcs.
Straight Section 120" or 144"	6 pcs.
Horizontal/Vertical Bends	4 pcs.
Tees	6 pcs.
Crosses	8 pcs.

Cover Joint Strip

- Used to join covers.
- Plastic.
- Only for use on flat covers
- Color - gray.
- (±) Insert tray width.

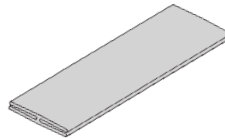

Catalog No.

● **99-9980-(±)**

Cable Cleats

- For additional information, see pages N-1 to N-5 in this catalog.

Trefoil Cable Cleats



Single Cable Cleats



● Green = Fastest shipped items ● Black = Normal lead-time items ● Red = Normally long lead-time items

All dimensions in parentheses are millimeters unless otherwise specified.

Section 1- Acceptable Manufacturers

- 1.01 Manufacturer: Subject to compliance with these specifications, Eaton's B-Line series cable tray systems shall be as manufactured by Eaton.

Section 2- Cable Tray Sections and Components

- 2.01 General: Except as otherwise indicated, provide metal cable trays, of types, classes and sizes indicated; with splice plates, bolts, nuts and washers for connecting units. Construct units with rounded edges and smooth surfaces; in compliance with applicable standards; and with the following additional construction features. Cable tray shall be installed according to the latest revision of NEMA VE 2.
- 2.02 Stainless Steel: Straight section and fitting side rails and rungs shall be made of AISI Type [304] [316] stainless steel. Transverse members (rungs) or corrugated bottoms shall be welded to the side rails with Type 316 stainless steel welding wire. Hardware shall be AISI Type 316 stainless steel.
- 2.03 Ladder Cable Trays shall consist of two longitudinal members (side rails) with transverse members (rungs) welded to the side rails. Rungs shall be spaced [6] [9] [12] inches apart. Rung spacing in radiused fittings shall be industry standard 9" and measured at the center of the tray's width. Each rung must be capable of supporting a 200 lb. concentrated load at the center of the cable tray with a safety factor of 1.5.
- 2.04 Cable tray loading depth shall be [3] [4] [5] inches per NEMA VE 1.
- 2.05 Straight sections shall be fabricated as I-beams. Straight sections shall be supplied in standard [12 foot] [24 foot] [10 foot (3 m)] [20 foot (6 m)] lengths.
- 2.06 Cable tray widths shall be [6] [9] [12] [18] [24] [30] [36] inches or as shown on drawings.
- 2.07 Splice plates shall be manufactured of high strength steel and be secured with 8 nuts and bolts per plate. The resistance of fixed splice connections between an adjacent section of tray shall not exceed 0.00033 ohm.
- 2.08 All fittings must have a minimum radius of [12] [24] [36] [48] inches.

Section 3- Loading Capacities and Testing

- 3.01 Cable tray shall be capable of carrying a uniformly distributed load of _____ lbs./ft. on a _____ ft. support span with a safety factor of 1.5 when supported as a simple span and tested per NEMA VE 1 5.2. In addition to the uniformly distributed load the cable tray shall support 200 lbs. concentrated load at mid-point of span. Load and safety factors specified are applicable to both the side rails and rung capacities. Cable tray shall be made to manufacturing tolerances as specified by NEMA.
- 3.02 Upon request, manufacturer shall provide test reports in accordance with the latest revision of NEMA VE 1 or CSA C22.2 No. 126.



How The Service Advisor Works

We know that your time is important! That's why the color-coding system in this catalog is designed to help you select products that fit your service needs. Products are marked to indicate the typical lead time for orders of 50 pieces or less.

Customer: How do I select my fittings so that I get the quickest turnaround?

Service Advisor: Each part of our selection chart is shown in colors. If any section of a part number is a different color, the part will typically ship with the longer lead time represented by the colors.

- Green = Fastest shipped items
- Black = Normal lead-time items
- Red = Normally long lead-time items

Example: 5 G - 09 - 90 HB 24

● ● ● ● ● ●

Part will have a long lead time because of the G material.

Changing the part number from G to A or P will change the coding to black and reduce lead time.

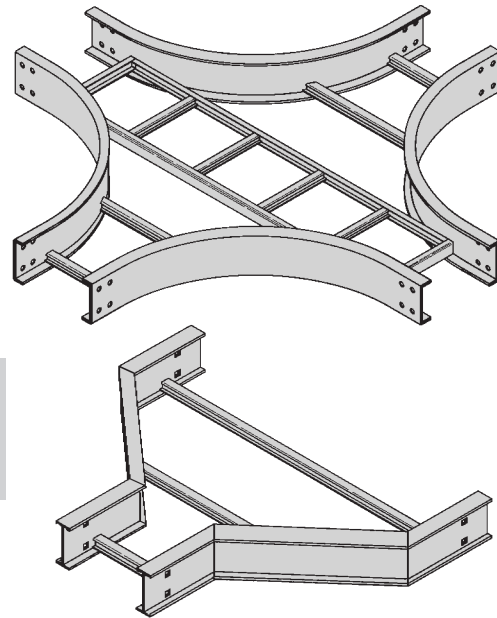
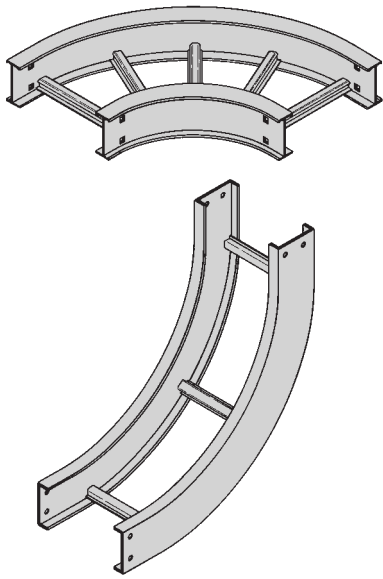

Fittings engineered with 3" tangents for splicing integrity.

Fittings Part Numbering

Example: **4 A - 24 - 90 HB 24** (9" rung spacing is standard)

Side Rail Height	Material	Width	Angle	Type	Radius
● 4 = 4" (101)	● A = Aluminum	● 06 = 6" (152)	● 30 = 30°	● HB = Horizontal Bend	● 12 = 12" (305)
● 5 = 5" (127)	● G = HDGAF	● 09 = 9" (228)	● 45 = 45°	● HT = Horizontal Tee	● 24 = 24" (609)
● 6 = 6" (152)	● P = Pre-Galvanized	● 12 = 12" (305)	● 60 = 60°	● HX = Horizontal Cross	● 36 = 36" (914)
● 7 = 7" (178)	● SS4 = 304 Stainless Steel	● 18 = 18" (457)	● 90 = 90°	● VI = Vertical Inside Bend	● 48 = 48" (1219)
	● SS6 = 316 Stainless Steel	● 24 = 24" (609)		● VO = Vertical Outside Bend	
		● 30 = 30" (762)		● VT = Vertical Tee	
		● 36 = 36" (914)		● VTU = Vertical Tee, Up	
				● HYR = Horizontal Wye, Right	
				● HYL = Horizontal Wye, Left	
				● CSF = Cable Support Fitting	
				● LR = Left Reducer Fitting	
				● RR = Right Reducer Fitting	
				● SR = Straight Reducer Fitting	

See page APP-2 for 6" fittings with 9A-6006 and 9A-6007 splice plates.

For flat Solid Bottom: Available 6" and Wider

Prefix
5PSB - 24 - 90HB24
 Solid Bottom

Note: Horizontal crosses and tees 30" or wider, with a radius of 36" or larger, will be of two-piece construction.

● Green = Fastest shipped items ● Black = Normal lead-time items ● Red = Normally long lead-time items

All dimensions in parentheses are millimeters unless otherwise specified.

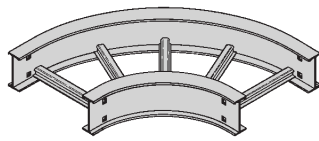

90° Horizontal Bend

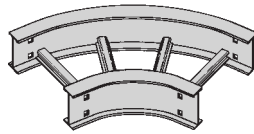
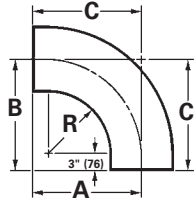

60° Horizontal Bend

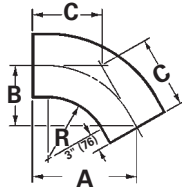

Horizontal Bend 90° 60° (HB)

1 pair splice plates with hardware included.

Bottoms manufactured:

- Ladder = 9" Rung Spacing
- VT & 04 = 4" Rung Spacing
- ST & SB = Flat sheet over 12" Rung Spacing

Bend Radius R in. (mm)	Tray Width in. (mm)	90° Horizontal Bend Dimensions				60° Horizontal Bend Dimensions			
		Catalog No.	A in. (mm)	B in. (mm)	C in. (mm)	Catalog No.	A in. (mm)	B in. (mm)	C in. (mm)
12 (305)	6 (152)	(Pre)-06-90HB12	18 (457)	18 (457)	18 (457)	(Pre)-06-60HB12	17 ¹ / ₂ (445)	10 ¹ / ₈ (257)	11 ¹¹ / ₁₆ (297)
	9 (228)	(Pre)-09-90HB12	19 ¹ / ₂ (495)	19 ¹ / ₂ (495)	19 ¹ / ₂ (495)	(Pre)-09-60HB12	18 ³ / ₁₆ (478)	10 ⁷ / ₈ (276)	12 ¹ / ₂ (318)
	12 (305)	(Pre)-12-90HB12	21 (533)	21 (533)	21 (533)	(Pre)-12-60HB12	20 ¹ / ₁₆ (510)	11 ⁵ / ₈ (295)	13 ³ / ₈ (340)
	18 (457)	(Pre)-18-90HB12	24 (610)	24 (610)	24 (610)	(Pre)-18-60HB12	22 ¹¹ / ₁₆ (576)	13 ³ / ₈ (333)	15 ¹ / ₈ (384)
	24 (609)	(Pre)-24-90HB12	27 (686)	27 (686)	27 (686)	(Pre)-24-60HB12	25 ⁵ / ₁₆ (643)	14 ⁵ / ₈ (372)	16 ⁷ / ₈ (429)
	30 (762)	(Pre)-30-90HB12	30 (762)	30 (762)	30 (762)	(Pre)-30-60HB12	27 ⁷ / ₈ (708)	16 ¹ / ₈ (410)	18 ⁹ / ₁₆ (472)
	36 (914)	(Pre)-36-90HB12	33 (838)	33 (838)	33 (838)	(Pre)-36-60HB12	30 ¹ / ₂ (775)	17 ⁵ / ₈ (448)	20 ⁵ / ₁₆ (516)
42 (1067)	(Pre)-42-90HB12	36 (914)	36 (914)	36 (914)	(Pre)-42-60HB12	33 ¹ / ₁₆ 840	19 ¹ / ₈ (486)	22 ¹ / ₁₆ (560)	
24 (610)	6 (152)	(Pre)-06-90HB24	30 (762)	30 (762)	30 (762)	(Pre)-06-60HB24	27 ⁷ / ₈ (708)	16 ¹ / ₈ (410)	18 ⁹ / ₁₆ (472)
	9 (228)	(Pre)-09-90HB24	31 ¹ / ₂ (800)	31 ¹ / ₂ (800)	31 ¹ / ₂ (800)	(Pre)-09-60HB24	29 ⁹ / ₁₆ (741)	16 ⁷ / ₈ (429)	19 ⁷ / ₁₆ (494)
	12 (305)	(Pre)-12-90HB24	33 (838)	33 (838)	33 (838)	(Pre)-12-60HB24	30 ¹ / ₂ (775)	17 ⁵ / ₈ (448)	20 ⁵ / ₁₆ (516)
	18 (457)	(Pre)-18-90HB24	36 (914)	36 (914)	36 (914)	(Pre)-18-60HB24	33 ¹ / ₁₆ (708)	19 ¹ / ₈ (486)	22 ¹ / ₁₆ (560)
	24 (609)	(Pre)-24-90HB24	39 (991)	39 (991)	39 (991)	(Pre)-24-60HB24	35 ¹¹ / ₁₆ (907)	20 ⁵ / ₈ (524)	23 ³ / ₁₆ (605)
	30 (762)	(Pre)-30-90HB24	42 (1067)	42 (1067)	42 (1067)	(Pre)-30-60HB24	38 ¹ / ₄ (972)	22 ¹ / ₈ (564)	25 ¹ / ₂ (648)
	36 (914)	(Pre)-36-90HB24	45 (1143)	45 (1143)	45 (1143)	(Pre)-36-60HB24	40 ⁷ / ₈ (1038)	23 ³ / ₈ (600)	27 ¹ / ₄ (692)
42 (1067)	(Pre)-42-90HB24	48 (1219)	48 (1219)	48 (1219)	(Pre)-42-60HB24	43 ¹ / ₂ (1105)	25 ¹ / ₈ (638)	29 (737)	
36 (914)	6 (152)	(Pre)-06-90HB36	42 (1067)	42 (1067)	(1067) (1067)	(Pre)-06-60HB36	38 ¹ / ₄ (971)	22 ¹ / ₈ (562)	25 ¹ / ₂ (648)
	9 (228)	(Pre)-09-90HB36	43 ¹ / ₂ (1105)	43 ¹ / ₂ (1105)	43 ¹ / ₂ (1105)	(Pre)-09-60HB36	39 ⁹ / ₁₆ (1005)	22 ⁷ / ₈ (581)	26 ³ / ₈ (670)
	12 (305)	(Pre)-12-90HB36	45 (1143)	45 (1143)	45 (1143)	(Pre)-12-60HB36	40 ⁷ / ₈ (1038)	23 ³ / ₈ (600)	27 ¹ / ₄ (692)
	18 (457)	(Pre)-18-90HB36	48 (1219)	48 (1219)	48 (1219)	(Pre)-18-60HB36	43 ¹ / ₂ (1105)	25 ¹ / ₈ (638)	29 (737)
	24 (609)	(Pre)-24-90HB36	51 (1295)	51 (1295)	51 (1295)	(Pre)-24-60HB36	46 ¹ / ₁₆ (1170)	26 ⁵ / ₈ (676)	30 ¹¹ / ₁₆ (780)
	30 (762)	(Pre)-30-90HB36	54 (1372)	54 (1372)	54 (1372)	(Pre)-30-60HB36	48 ¹ / ₁₆ (1237)	28 ³ / ₈ (714)	32 ⁷ / ₁₆ (824)
	36 (914)	(Pre)-36-90HB36	57 (1448)	57 (1448)	57 (1448)	(Pre)-36-60HB36	51 ¹ / ₄ (1302)	29 ⁵ / ₈ (753)	34 ³ / ₁₆ (869)
42 (1067)	(Pre)-42-90HB36	60 (1524)	60 (1524)	60 (1524)	(Pre)-42-60HB36	53 ⁷ / ₈ (1368)	31 ¹ / ₈ (791)	35 ¹⁵ / ₁₆ (913)	
48 (1220)	6 (152)	(Pre)-06-90HB48	54 (1372)	54 (1372)	54 (1372)	(Pre)-06-60HB48	48 ¹ / ₁₆ (1221)	28 ³ / ₈ (715)	32 ¹¹ / ₁₆ (830)
	9 (228)	(Pre)-09-90HB48	55 ¹ / ₂ (1410)	55 ¹ / ₂ (1410)	55 ¹ / ₂ (1410)	(Pre)-09-60HB48	49 ¹⁵ / ₁₆ (1268)	28 ⁷ / ₈ (734)	33 ⁵ / ₁₆ (846)
	12 (305)	(Pre)-12-90HB48	57 (1448)	57 (1448)	57 (1448)	(Pre)-12-60HB48	51 ¹ / ₄ (1302)	29 ⁵ / ₈ (753)	34 ³ / ₁₆ (869)
	18 (457)	(Pre)-18-90HB48	60 (1524)	60 (1524)	60 (1524)	(Pre)-18-60HB48	53 ⁷ / ₈ (1368)	31 ¹ / ₈ (737)	35 ¹⁵ / ₁₆ (913)
	24 (609)	(Pre)-24-90HB48	63 (1600)	63 (1600)	63 (1600)	(Pre)-24-60HB48	56 ⁷ / ₁₆ (1434)	32 ⁵ / ₈ (829)	37 ³ / ₈ (956)
	30 (762)	(Pre)-30-90HB48	66 (1676)	66 (1676)	66 (1676)	(Pre)-30-60HB48	59 ¹ / ₁₆ (1500)	34 ¹ / ₈ (867)	39 ³ / ₈ (1000)
	36 (914)	(Pre)-36-90HB48	69 (1753)	69 (1753)	69 (1753)	(Pre)-36-60HB48	61 ¹¹ / ₁₆ (1567)	35 ⁵ / ₈ (905)	41 ¹ / ₈ (1045)
42 (1067)	(Pre)-42-90HB48	72 (1829)	72 (1829)	72 (1829)	(Pre)-42-60HB48	64 ¹ / ₄ (1632)	37 ¹ / ₈ (943)	42 ¹³ / ₁₆ (1087)	

Series 2, 3, 4, & 5 Fittings

(PRE) = Prefix. See page L-3 for catalog number prefix.

Width dimensions are to inside wall. For aluminum fittings add 1.5 inches (38mm) for total outside width.

Manufacturing tolerances apply to all dimensions.

All dimensions in parentheses are millimeters unless otherwise specified.

Series 2, 3, 4, & 5 - Fittings

Horizontal Bend 45° 30° (HB)

1 pair splice plates with hardware included.

Bottoms manufactured:

- Ladder = 9" Rung Spacing
- VT & 04 = 4" Rung Spacing
- ST & SB = Flat sheet over 12" Rung Spacing

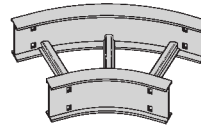

45° Horizontal Bend

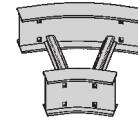

30° Horizontal Bend

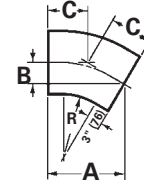
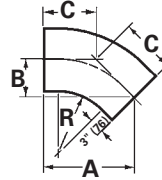

Bend Radius R in. (mm)	Tray Width in. (mm)	45° Horizontal Bend				30° Horizontal Bend			
		Catalog No.	Dimensions			Catalog No.	Dimensions		
			A in. (mm)	B in. (mm)	C in. (mm)		A in. (mm)	B in. (mm)	C in. (mm)
12 (305)	6 (152)	(Pre)-06-45HB12	15 ³ / ₄ (400)	6 ¹ / ₂ (165)	9 ³ / ₁₆ (233)	(Pre)-06-30HB12	13 ¹ / ₈ (333)	3 ¹ / ₂ (89)	7 (179)
	9 (228)	(Pre)-09-45HB12	16 ¹³ / ₁₆ (427)	6 ¹⁵ / ₁₆ (176)	9 ¹³ / ₁₆ (249)	(Pre)-09-30HB12	13 ⁷ / ₈ (352)	3 ¹¹ / ₁₆ (94)	7 ⁷ / ₁₆ (189)
	12 (305)	(Pre)-12-45HB12	17 ⁷ / ₈ (454)	7 ³ / ₈ (187)	10 ⁷ / ₁₆ (265)	(Pre)-12-30HB12	14 ⁵ / ₈ (372)	3 ¹⁵ / ₁₆ (100)	7 ¹³ / ₁₆ (198)
	18 (457)	(Pre)-18-45HB12	20 (508)	8 ¹ / ₄ (210)	11 ¹¹ / ₁₆ (297)	(Pre)-18-30HB12	16 ¹ / ₈ (410)	4 ⁵ / ₁₆ (135)	8 ⁵ / ₈ (219)
	24 (609)	(Pre)-24-45HB12	22 ¹ / ₁₆ (560)	9 ¹ / ₈ (232)	12 ¹⁵ / ₁₆ (329)	(Pre)-24-30HB12	17 ⁵ / ₈ (448)	4 ¹¹ / ₁₆ (119)	9 ⁷ / ₁₆ (240)
	30 (762)	(Pre)-30-45HB12	24 ³ / ₁₆ (614)	10 (254)	14 ³ / ₁₆ (360)	(Pre)-30-30HB12	19 ¹ / ₈ (486)	5 ¹ / ₈ (130)	10 ¹ / ₄ (260)
	36 (914)	(Pre)-36-45HB12	26 ⁵ / ₁₆ (668)	10 ¹⁵ / ₁₆ (278)	15 ⁷ / ₁₆ (392)	(Pre)-36-30HB12	20 ⁵ / ₈ (524)	5 ¹ / ₂ (140)	11 ¹ / ₁₆ (281)
42 (1067)	(Pre)-42-45HB12	28 ⁷ / ₁₆ (722)	11 ¹³ / ₁₆ (300)	16 ¹¹ / ₁₆ (424)	(Pre)-42-30HB12	22 ¹ / ₈ (562)	5 ¹⁵ / ₁₆ (151)	11 ¹³ / ₁₆ (300)	
24 (610)	6 (152)	(Pre)-06-45HB24	24 ³ / ₁₆ (614)	10 (254)	14 ³ / ₁₆ (360)	(Pre)-06-30HB24	19 ¹ / ₈ (486)	5 ¹ / ₈ (130)	10 ¹ / ₄ (260)
	9 (228)	(Pre)-09-45HB24	25 ¹ / ₄ (641)	10 ¹ / ₂ (267)	14 ¹³ / ₁₆ (376)	(Pre)-09-30HB24	19 ⁷ / ₈ (505)	5 ⁵ / ₁₆ (135)	10 ⁵ / ₈ (270)
	12 (305)	(Pre)-12-45HB24	26 ⁵ / ₁₆ (668)	10 ¹⁵ / ₁₆ (278)	15 ⁷ / ₁₆ (392)	(Pre)-12-30HB24	20 ⁵ / ₈ (524)	5 ¹ / ₂ (140)	11 ¹ / ₁₆ (281)
	18 (457)	(Pre)-18-45HB24	28 ⁷ / ₁₆ (722)	11 ¹³ / ₁₆ (300)	16 ¹¹ / ₁₆ (424)	(Pre)-18-30HB24	22 ¹ / ₈ (562)	5 ¹⁵ / ₁₆ (151)	11 ¹³ / ₁₆ (300)
	24 (609)	(Pre)-24-45HB24	30 ⁹ / ₁₆ (766)	12 ¹¹ / ₁₆ (322)	17 ¹⁵ / ₁₆ (456)	(Pre)-24-30HB24	23 ⁵ / ₈ (600)	6 ⁵ / ₁₆ (160)	12 ⁵ / ₈ (321)
	30 (762)	(Pre)-30-45HB24	32 ¹¹ / ₁₆ (830)	13 ⁹ / ₁₆ (344)	19 ¹ / ₈ (486)	(Pre)-30-30HB24	25 ¹ / ₈ (638)	6 ³ / ₄ (172)	13 ⁷ / ₁₆ (341)
	36 (914)	(Pre)-36-45HB24	34 ¹³ / ₁₆ (884)	14 ⁷ / ₁₆ (367)	20 ³ / ₈ (518)	(Pre)-36-30HB24	26 ⁵ / ₈ (676)	7 ¹ / ₈ (181)	14 ¹ / ₄ (362)
42 (1067)	(Pre)-42-45HB24	36 ¹⁵ / ₁₆ (938)	15 ⁵ / ₁₆ (389)	21 ⁵ / ₈ (549)	(Pre)-42-30HB24	28 ¹ / ₈ (715)	7 ¹ / ₂ (191)	15 ¹ / ₁₆ (383)	
36 (914)	6 (152)	(Pre)-06-45HB36	32 ¹¹ / ₁₆ (830)	13 ⁹ / ₁₆ (344)	19 ¹ / ₈ (486)	(Pre)-06-30HB36	25 ¹ / ₈ (638)	6 ³ / ₄ (171)	13 ⁷ / ₁₆ (341)
	9 (228)	(Pre)-09-45HB36	33 ³ / ₄ (857)	14 (356)	19 ³ / ₄ (502)	(Pre)-09-30HB36	25 ⁷ / ₈ (657)	6 ¹⁵ / ₁₆ (176)	13 ³ / ₈ (352)
	12 (305)	(Pre)-12-45HB36	34 ¹³ / ₁₆ (884)	14 ⁷ / ₁₆ (367)	20 ³ / ₈ (518)	(Pre)-12-30HB36	26 ⁵ / ₈ (676)	7 ¹ / ₈ (181)	14 ¹ / ₄ (362)
	18 (457)	(Pre)-18-45HB36	36 ¹⁵ / ₁₆ (938)	15 ⁵ / ₁₆ (389)	21 ⁵ / ₈ (549)	(Pre)-18-30HB36	28 ¹ / ₈ (715)	7 ¹ / ₂ (191)	15 ¹ / ₁₆ (383)
	24 (609)	(Pre)-24-45HB36	39 ¹ / ₁₆ (992)	16 ³ / ₁₆ (411)	22 ⁷ / ₈ (581)	(Pre)-24-30HB36	29 ⁵ / ₈ (753)	7 ¹⁵ / ₁₆ (202)	15 ⁷ / ₈ (403)
	30 (762)	(Pre)-30-45HB36	41 ³ / ₁₆ (1046)	17 ¹ / ₁₆ (433)	24 ¹ / ₈ (613)	(Pre)-30-30HB36	31 ¹ / ₈ (790)	8 ⁵ / ₁₆ (211)	16 ¹¹ / ₁₆ (424)
	36 (914)	(Pre)-36-45HB36	43 ⁵ / ₁₆ (1100)	17 ¹⁵ / ₁₆ (456)	25 ³ / ₈ (645)	(Pre)-36-30HB36	32 ⁵ / ₈ (829)	8 ³ / ₄ (222)	17 ¹ / ₂ (445)
42 (1067)	(Pre)-42-45HB36	45 ⁷ / ₁₆ (1154)	18 ¹³ / ₁₆ (478)	26 ⁵ / ₈ (676)	(Pre)-42-30HB36	34 ¹ / ₈ (867)	9 ¹ / ₈ (232)	18 ¹ / ₄ (464)	
48 (1220)	6 (152)	(Pre)-06-45HB48	41 ³ / ₁₆ (1046)	17 ¹ / ₁₆ (433)	24 ¹ / ₈ (613)	(Pre)-06-30HB48	31 ¹ / ₈ (791)	8 ⁵ / ₁₆ (211)	16 ¹¹ / ₁₆ (424)
	9 (228)	(Pre)-09-45HB48	42 ¹ / ₄ (1073)	17 ¹ / ₂ (445)	24 ³ / ₄ (629)	(Pre)-09-30HB48	31 ⁷ / ₈ (810)	8 ⁹ / ₁₆ (218)	17 ¹ / ₁₆ (433)
	12 (305)	(Pre)-12-45HB48	43 ⁵ / ₁₆ (1100)	17 ¹⁵ / ₁₆ (456)	25 ³ / ₈ (645)	(Pre)-12-30HB48	32 ⁵ / ₈ (829)	8 ³ / ₄ (222)	17 ¹ / ₂ (445)
	18 (457)	(Pre)-18-45HB48	45 ⁷ / ₁₆ (1154)	18 ¹³ / ₁₆ (487)	26 ⁵ / ₈ (676)	(Pre)-18-30HB48	34 ¹ / ₈ (867)	9 ¹ / ₈ (232)	18 ¹ / ₄ (464)
	24 (609)	(Pre)-24-45HB48	47 ⁹ / ₁₆ (1208)	19 ¹¹ / ₁₆ (500)	27 ⁷ / ₈ (708)	(Pre)-24-30HB48	35 ⁵ / ₈ (905)	9 ⁹ / ₁₆ (243)	19 ¹ / ₁₆ (484)
	30 (762)	(Pre)-30-45HB48	49 ¹¹ / ₁₆ (1262)	20 ⁹ / ₁₆ (522)	29 ¹ / ₈ (740)	(Pre)-30-30HB48	37 ¹ / ₈ (943)	9 ¹⁵ / ₁₆ (252)	19 ⁷ / ₈ (505)
	36 (914)	(Pre)-36-45HB48	51 ¹³ / ₁₆ (1316)	21 ⁷ / ₁₆ (545)	30 ⁵ / ₁₆ (770)	(Pre)-36-30HB48	38 ⁵ / ₈ (981)	10 ⁵ / ₁₆ (262)	20 ¹¹ / ₁₆ (525)
42 (1067)	(Pre)-42-45HB48	54 ¹⁵ / ₁₆ (1395)	22 ⁵ / ₁₆ (567)	31 ⁹ / ₁₆ (802)	(Pre)-42-30HB48	40 ¹ / ₈ (1019)	10 ³ / ₄ (273)	21 ¹ / ₂ (546)	

(Pre) See page L-3 for catalog number prefix.

Width dimensions are to inside wall. For aluminum fittings add 1.5 inches (38mm) for total outside width.

Manufacturing tolerances apply to all dimensions.

All dimensions in parentheses are millimeters unless otherwise specified.

Horizontal Tee (HT)

2 pair splice plates with hardware included.

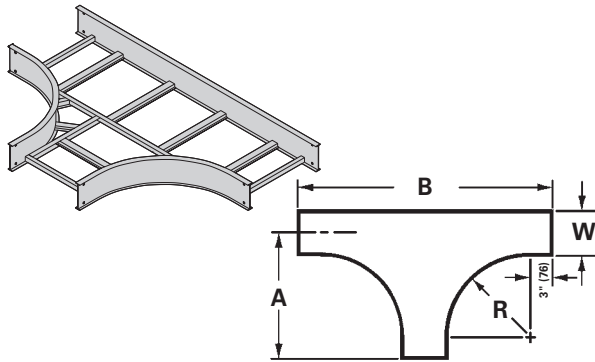

Horizontal Cross (HX)

3 pair splice plates with hardware included.

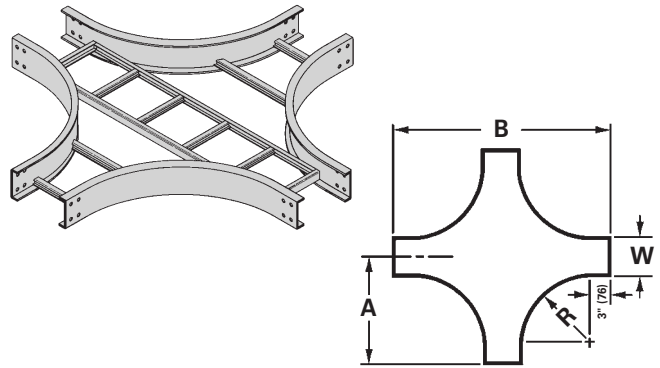

Bend Radius R	Tray Width in. (mm)	Horizontal Tee			Horizontal Cross		
		Catalog Number	Dimensions		Catalog Number	Dimensions	
			in.	(mm)		in.	(mm)
12 (305)	6 (152)	(Prefix)-06-HT12	18 (457)	36 (914)	(Prefix)-06-HX12	18 (457)	36 (914)
	9 (229)	(Prefix)-09-HT12	19½ (496)	39 (991)	(Prefix)-09-HX12	19½ (496)	39 (991)
	12 (305)	(Prefix)-12-HT12	21 (533)	42 (1067)	(Prefix)-12-HX12	21 (533)	42 (1067)
	18 (457)	(Prefix)-18-HT12	24 (609)	48 (1219)	(Prefix)-18-HX12	24 (609)	48 (1219)
	24 (609)	(Prefix)-24-HT12	27 (686)	54 (1372)	(Prefix)-24-HX12	27 (686)	54 (1372)
	30 (762)	(Prefix)-30-HT12	30 (762)	60 (1524)	(Prefix)-30-HX12	30 (762)	60 (1524)
	36 (914)	(Prefix)-36-HT12	33 (838)	66 (1676)	(Prefix)-36-HX12	33 (838)	66 (1676)
24 (610)	42 (1067)	(Prefix)-42-HT12	36 (914)	72 (1829)	(Prefix)-42-HX12	36 (914)	72 (1829)
	6 (152)	(Prefix)-06-HT24	30 (762)	60 (1524)	(Prefix)-06-HX24	30 (762)	60 (1524)
	9 (229)	(Prefix)-09-HT24	31½ (800)	63 (1600)	(Prefix)-09-HX24	31½ (800)	63 (1600)
	12 (305)	(Prefix)-12-HT24	33 (838)	66 (1676)	(Prefix)-12-HX24	33 (838)	66 (1676)
	18 (457)	(Prefix)-18-HT24	36 (914)	72 (1829)	(Prefix)-18-HX24	36 (914)	72 (1829)
	24 (609)	(Prefix)-24-HT24	39 (991)	78 (1982)	(Prefix)-24-HX24	39 (991)	78 (1982)
	30 (762)	(Prefix)-30-HT24	42 (1067)	84 (2134)	(Prefix)-30-HX24	42 (1067)	84 (2134)
36 (914)	36 (914)	(Prefix)-36-HT24	45 (1143)	90 (2286)	(Prefix)-36-HX24	45 (1143)	90 (2286)
	42 (1067)	(Prefix)-42-HT24	48 (1219)	96 (2438)	(Prefix)-42-HX24	48 (1219)	96 (2438)
	6 (152)	(Prefix)-06-HT36	42 (1067)	84 (2134)	(Prefix)-06-HX36	42 (1067)	84 (2134)
	9 (229)	(Prefix)-09-HT36	43½ (1105)	87 (2210)	(Prefix)-09-HX36	43½ (1105)	87 (2210)
	12 (305)	(Prefix)-12-HT36	45 (1143)	90 (2286)	(Prefix)-12-HX36	45 (1143)	90 (2286)
	18 (457)	(Prefix)-18-HT36	48 (1219)	96 (2438)	(Prefix)-18-HX36	48 (1219)	96 (2438)
	24 (609)	(Prefix)-24-HT36	51 (1295)	102 (2590)	(Prefix)-24-HX36	51 (1295)	102 (2590)
48 (1220)	30 (762)	(Prefix)-30-HT36	54 (1372)	108 (2744)	(Prefix)-30-HX36	54 (1372)	108 (2744)
	36 (914)	(Prefix)-36-HT36	57 (1448)	114 (2896)	(Prefix)-36-HX36	57 (1448)	114 (2896)
	42 (1067)	(Prefix)-42-HT36	60 (1524)	120 (3048)	(Prefix)-42-HX36	60 (1524)	120 (3048)
	6 (152)	(Prefix)-06-HT48	54 (1372)	108 (2744)	(Prefix)-06-HX48	54 (1372)	108 (2744)
	9 (229)	(Prefix)-09-HT48	55½ (1410)	111 (2820)	(Prefix)-09-HX48	55½ (1410)	111 (2820)
	12 (305)	(Prefix)-12-HT48	57 (1448)	114 (2896)	(Prefix)-12-HX48	57 (1448)	114 (2896)
	18 (457)	(Prefix)-18-HT48	60 (1524)	120 (3048)	(Prefix)-18-HX48	60 (1524)	120 (3048)
48 (1220)	24 (609)	(Prefix)-24-HT48	63 (1600)	126 (3200)	(Prefix)-24-HX48	63 (1600)	126 (3200)
	30 (762)	(Prefix)-30-HT48	66 (1676)	132 (3353)	(Prefix)-30-HX48	66 (1676)	132 (3353)
	36 (914)	(Prefix)-36-HT48	69 (1753)	138 (3535)	(Prefix)-36-HX48	69 (1753)	138 (3535)
	42 (1067)	(Prefix)-42-HT48	72 (1829)	144 (3658)	(Prefix)-42-HX48	72 (1829)	144 (3658)

(PRE) = Prefix. See page L-3 for catalog number prefix.

Width dimensions are to inside wall. For aluminum fittings add 1.5 inches (38mm) for total outside width. Manufacturing tolerances apply to all dimensions.

All dimensions in parentheses are millimeters unless otherwise specified.

Series 2, 3, 4, & 5 - Fittings

Reducers (LR, SR, RR)

1 pair splice plates with hardware included.

Reducer Part Numbering

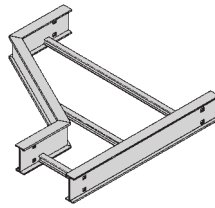
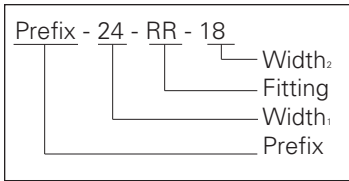

Left Reducer - LR

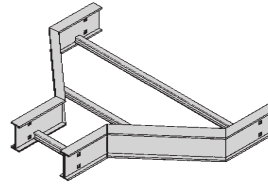

Straight Reducer SR

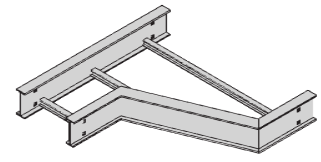

Right Reducer -RR

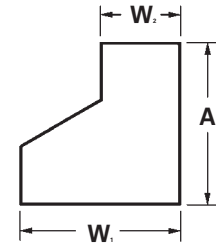
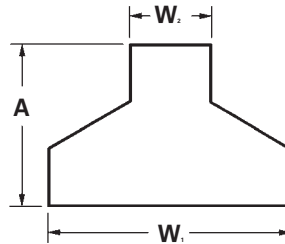
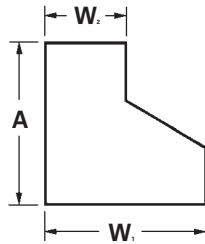

Tray Width		Left Hand Reducer		Straight Reducer		Right Hand Reducer	
W ₁ in. (mm)	W ₂ in. (mm)	Catalog No.	A in. (mm)	Catalog No.	A in. (mm)	Catalog No.	A in. (mm)
9 (228)	6 (152)	(Prefix)-09-LR06	9 ³ / ₄ (248)	(Prefix)-09-SR06	8 ¹⁵ / ₁₆ (227)	(Prefix)-09-RR06	9 ³ / ₄ (248)
12 (305)	6 (152)	(Prefix)-12-LR06	11 ¹ / ₂ (292)	(Prefix)-12-SR06	9 ³ / ₄ (248)	(Prefix)-12-RR06	11 ¹ / ₂ (292)
	9 (228)	(Prefix)-12-LR09	9 ³ / ₄ (248)	(Prefix)-12-SR09	8 ¹⁵ / ₁₆ (227)	(Prefix)-12-RR09	9 ³ / ₄ (248)
18 (457)	6 (152)	(Prefix)-18-LR06	14 ¹⁵ / ₁₆ (379)	(Prefix)-18-SR06	11 ¹ / ₂ (292)	(Prefix)-18-RR06	14 ¹⁵ / ₁₆ (379)
	9 (228)	(Prefix)-18-LR09	13 ³ / ₁₆ (340)	(Prefix)-18-SR09	10 ⁵ / ₈ (270)	(Prefix)-18-RR09	13 ³ / ₁₆ (340)
	12 (305)	(Prefix)-18-LR12	11 ¹ / ₂ (292)	(Prefix)-18-SR12	9 ³ / ₄ (248)	(Prefix)-18-RR12	11 ¹ / ₂ (292)
24 (609)	6 (152)	(Prefix)-24-LR06	18 ³ / ₈ (467)	(Prefix)-24-SR06	13 ¹ / ₄ (336)	(Prefix)-24-RR06	18 ³ / ₈ (467)
	9 (228)	(Prefix)-24-LR09	16 ¹¹ / ₁₆ (424)	(Prefix)-24-SR09	12 ³ / ₈ (314)	(Prefix)-24-RR09	16 ¹¹ / ₁₆ (424)
	12 (305)	(Prefix)-24-LR12	14 ¹⁵ / ₁₆ (379)	(Prefix)-24-SR12	11 ¹ / ₂ (292)	(Prefix)-24-RR12	14 ¹⁵ / ₁₆ (379)
	18 (457)	(Prefix)-24-LR18	11 ¹ / ₂ (292)	(Prefix)-24-SR18	9 ³ / ₄ (248)	(Prefix)-24-RR18	11 ¹ / ₂ (292)
30 (762)	6 (152)	(Prefix)-30-LR06	21 ⁷ / ₈ (555)	(Prefix)-30-SR06	14 ¹⁵ / ₁₆ (379)	(Prefix)-30-RR06	21 ⁷ / ₈ (555)
	9 (228)	(Prefix)-30-LR09	20 ¹ / ₈ (511)	(Prefix)-30-SR09	14 ¹ / ₈ (359)	(Prefix)-30-RR09	20 ¹ / ₈ (511)
	12 (305)	(Prefix)-30-LR12	18 ³ / ₈ (467)	(Prefix)-30-SR12	13 ¹ / ₄ (336)	(Prefix)-30-RR12	18 ³ / ₈ (467)
	18 (457)	(Prefix)-30-LR18	14 ¹⁵ / ₁₆ (379)	(Prefix)-30-SR18	11 ¹ / ₂ (292)	(Prefix)-30-RR18	14 ¹⁵ / ₁₆ (379)
	24 (609)	(Prefix)-30-LR24	11 ¹ / ₂ (292)	(Prefix)-30-SR24	9 ³ / ₄ (248)	(Prefix)-30-RR24	11 ¹ / ₂ (292)
36 (914)	6 (152)	(Prefix)-36-LR06	25 ⁵ / ₁₆ (643)	(Prefix)-36-SR06	16 ¹¹ / ₁₆ (424)	(Prefix)-36-RR06	25 ⁵ / ₁₆ (643)
	9 (228)	(Prefix)-36-LR09	23 ⁹ / ₁₆ (598)	(Prefix)-36-SR09	15 ¹³ / ₁₆ (402)	(Prefix)-36-RR09	23 ⁹ / ₁₆ (598)
	12 (305)	(Prefix)-36-LR12	21 ⁷ / ₈ (555)	(Prefix)-36-SR12	14 ¹⁵ / ₁₆ (379)	(Prefix)-36-RR12	21 ⁷ / ₈ (555)
	18 (457)	(Prefix)-36-LR18	18 ³ / ₈ (467)	(Prefix)-36-SR18	13 ¹ / ₄ (336)	(Prefix)-36-RR18	18 ³ / ₈ (467)
	24 (609)	(Prefix)-36-LR24	14 ¹⁵ / ₁₆ (379)	(Prefix)-36-SR24	11 ¹ / ₂ (292)	(Prefix)-36-RR24	14 ¹⁵ / ₁₆ (379)
	30 (762)	(Prefix)-36-LR30	11 ¹ / ₂ (292)	(Prefix)-36-SR30	9 ³ / ₄ (248)	(Prefix)-36-RR30	11 ¹ / ₂ (292)
42 (1067)	6 (152)	(Prefix)-42-LR06	28 ³ / ₄ (730)	(Prefix)-42-SR06	18 ³ / ₈ (467)	(Prefix)-42-RR06	28 ³ / ₄ (730)
	9 (228)	(Prefix)-42-LR09	27 ¹ / ₁₆ (687)	(Prefix)-42-SR09	17 ⁹ / ₁₆ (446)	(Prefix)-42-RR09	27 ¹ / ₁₆ (687)
	12 (305)	(Prefix)-42-LR12	25 ⁵ / ₁₆ (643)	(Prefix)-42-SR12	16 ¹¹ / ₁₆ (424)	(Prefix)-42-RR12	25 ⁵ / ₁₆ (643)
	18 (457)	(Prefix)-42-LR18	21 ⁷ / ₈ (555)	(Prefix)-42-SR18	14 ¹⁵ / ₁₆ (379)	(Prefix)-42-RR18	21 ⁷ / ₈ (555)
	24 (609)	(Prefix)-42-LR24	18 ³ / ₈ (467)	(Prefix)-42-SR24	13 ¹ / ₄ (336)	(Prefix)-42-RR24	18 ³ / ₈ (467)
	30 (762)	(Prefix)-42-LR30	14 ¹⁵ / ₁₆ (379)	(Prefix)-42-SR30	11 ¹ / ₂ (292)	(Prefix)-42-RR30	14 ¹⁵ / ₁₆ (379)
	36 (914)	(Prefix)-42-LR36	11 ¹ / ₂ (292)	(Prefix)-42-SR36	9 ³ / ₄ (248)	(Prefix)-42-RR36	11 ¹ / ₂ (292)

(Prefix) See page L-3 for catalog number prefix.

Width dimensions are to inside wall. For aluminum fittings add 1.5 inches (38mm) for total outside width. Manufacturing tolerances apply to all dimensions.

All dimensions in parentheses are millimeters unless otherwise specified.

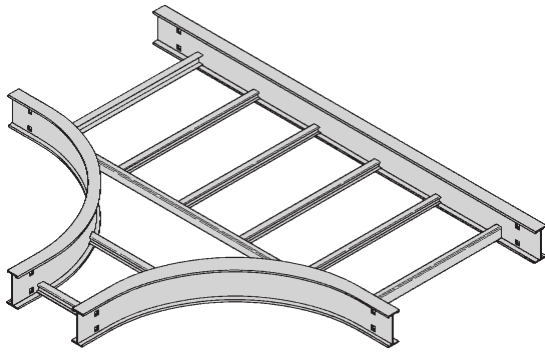

Horizontal Reducing Tee (HT)
2 pair splice plates with hardware included.

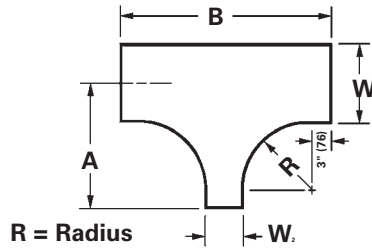

Prefix - 36 - 18 HT 24
 Radius
 Fitting
 Width W₂
 Width W₁
 To complete catalog number, insert fitting prefix.

Tray Width		* Insert Radius (12", 24", 36", or 48") Catalog No.	12" Radius		24" Radius		36" Radius		48" Radius	
W1 in. mm	W2 in. mm		A in. mm	B in. mm	A in. mm	B in. mm	A in. mm	B in. mm	A in. mm	B in. mm
9 (228)	6 (152)	(Prefix)-09-06-HT*	19½ (496)	36 (914)	31½ (800)	60 (1524)	43 (1092)	84 (2134)	55½ (1410)	108 (2743)
12 (305)	6 (152)	(Prefix)-12-06-HT*	21 (533)	36 (914)	33 (838)	60 (1524)	45 (1143)	84 (2134)	57 (1448)	108 (2743)
	9 (228)	(Prefix)-12-09-HT*	21 (533)	39 (991)	33 (838)	63 (1600)	45 (1143)	87 (2210)	57 (1448)	111 (2819)
18 (457)	6 (152)	(Prefix)-18-06-HT*	24 (609)	36 (914)	36 (914)	60 (1524)	48 (1143)	84 (2134)	60 (1524)	108 (2743)
	9 (228)	(Prefix)-18-09-HT*	24 (609)	39 (991)	36 (914)	63 (1600)	48 (1219)	87 (2210)	60 (1524)	111 (2819)
	12 (305)	(Prefix)-18-12-HT*	24 (609)	42 (1067)	36 (914)	66 (1676)	48 (1219)	90 (2286)	60 (1524)	114 (2895)
24 (609)	6 (152)	(Prefix)-24-06-HT*	27 (686)	36 (914)	39 (991)	60 (1524)	51 (1295)	84 (2134)	63 (1600)	108 (2743)
	9 (228)	(Prefix)-24-09-HT*	27 (686)	39 (991)	39 (991)	63 (1600)	51 (1295)	87 (2210)	63 (1600)	111 (2819)
	12 (305)	(Prefix)-24-12-HT*	27 (686)	42 (1067)	39 (991)	66 (1676)	51 (1295)	90 (2286)	63 (1600)	114 (2895)
	18 (457)	(Prefix)-24-18-HT*	27 (686)	48 (1219)	39 (991)	72 (1829)	51 (1295)	96 (2438)	63 (1600)	120 (3048)
30 (762)	6 (152)	(Prefix)-30-06-HT*	30 (762)	36 (914)	42 (1067)	60 (1524)	54 (1372)	84 (2134)	66 (1676)	108 (2743)
	9 (228)	(Prefix)-30-09-HT*	30 (762)	39 (991)	42 (1067)	63 (1600)	54 (1372)	87 (2210)	66 (1676)	111 (2819)
	12 (305)	(Prefix)-30-12-HT*	30 (762)	42 (1067)	42 (1067)	66 (1676)	54 (1372)	90 (2286)	66 (1676)	114 (2895)
	18 (457)	(Prefix)-30-18-HT*	30 (762)	48 (1219)	42 (1067)	72 (1829)	54 (1372)	96 (2438)	66 (1676)	120 (3048)
	24 (609)	(Prefix)-30-24-HT*	30 (762)	54 (1372)	42 (1067)	78 (1981)	54 (1372)	102 (2591)	66 (1676)	126 (3200)
36 (914)	6 (152)	(Prefix)-30-06-HT*	33 (838)	36 (914)	45 (1143)	60 (1524)	57 (1448)	84 (2134)	69 (1753)	108 (2743)
	9 (228)	(Prefix)-36-09-HT*	33 (838)	39 (991)	45 (1143)	63 (1600)	57 (1448)	87 (2210)	69 (1753)	111 (2819)
	12 (305)	(Prefix)-36-12-HT*	33 (838)	42 (1067)	45 (1143)	66 (1676)	57 (1448)	90 (2286)	69 (1753)	114 (2895)
	18 (457)	(Prefix)-36-18-HT*	33 (838)	48 (1219)	45 (1143)	72 (1829)	57 (1448)	96 (2438)	69 (1753)	120 (3048)
	24 (609)	(Prefix)-36-24-HT*	33 (838)	54 (1372)	45 (1143)	78 (1981)	57 (1448)	102 (2591)	69 (1753)	126 (3200)
42 (1067)	30 (762)	(Prefix)-36-30-HT*	33 (838)	60 (1524)	45 (1143)	84 (2134)	57 (1448)	108 (2743)	69 (1753)	132 (3353)
	6 (152)	(Prefix)-42-06-HT*	36 (914)	36 (914)	48 (1219)	60 (1524)	60 (1524)	84 (2134)	72 (1829)	108 (2743)
	9 (228)	(Prefix)-42-09-HT*	36 (914)	39 (991)	48 (1219)	63 (1600)	60 (1524)	87 (2210)	72 (1829)	111 (2819)
	12 (305)	(Prefix)-42-12-HT*	36 (914)	42 (1067)	48 (1219)	66 (1676)	60 (1524)	90 (2286)	72 (1829)	114 (2895)
	18 (457)	(Prefix)-42-18-HT*	36 (914)	48 (1219)	48 (1219)	72 (1829)	60 (1524)	96 (2438)	72 (1829)	120 (3048)
	24 (609)	(Prefix)-42-24-HT*	36 (914)	54 (1372)	48 (1219)	78 (1981)	60 (1524)	102 (2591)	72 (1829)	126 (3200)
36 (914)	30 (762)	(Prefix)-42-30-HT*	36 (914)	60 (1524)	48 (1219)	84 (2134)	60 (1524)	108 (2743)	72 (1829)	132 (3353)
	36 (914)	(Prefix)-42-36-HT*	36 (914)	66 (1676)	48 (1219)	90 (2286)	60 (1524)	114 (2895)	72 (1829)	138 (3505)

(Prefix) See page L-3 for catalog number prefix.

Width dimensions are to inside wall. For aluminum fittings add 1.5 inches (38mm) for total outside width. Manufacturing tolerances apply to all dimensions.

All dimensions in parentheses are millimeters unless otherwise specified.

Series 2, 3, 4, & 5 - Fittings

Horizontal Expanding Tee (HT)

2 pair splice plates with hardware included.

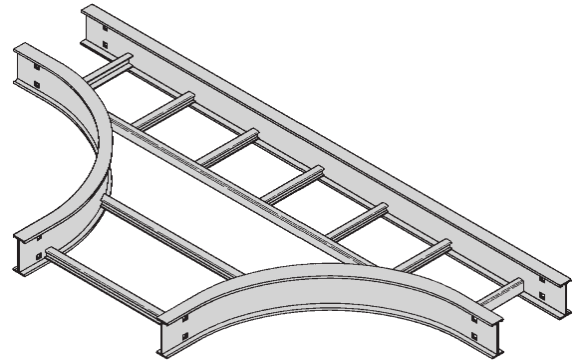
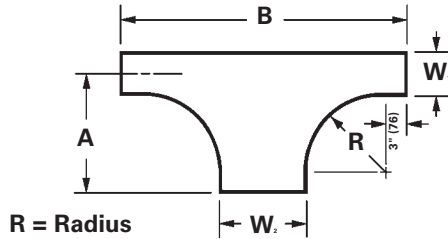

Prefix - 09 - 30 HT 12

Radius
Fitting
Width W₂
Width W₁

To complete catalog number, insert fitting prefix.

Series 2, 3, 4, & 5 Fittings

Tray Width		* Insert Radius (12", 24", 36", or 48") Catalog No.	12" Radius		24" Radius		36" Radius		48" Radius		
W1 in. mm	W2 in. mm		A in. mm	B in. mm	A in. mm	B in. mm	A in. mm	B in. mm	A in. mm	B in. mm	
6 (152)	9	228	(Prefix)-06-09-HT*	18 (457)	39 (991)	30 (762)	63 (1600)	42 (1067)	87 (2210)	54 (1372)	111 2819
	12	(305)	(Prefix)-06-12-HT*	18 (457)	42 (1067)	30 (762)	66 (1676)	42 (1067)	90 (2286)	54 (1372)	114 (2895)
	18	(457)	(Prefix)-06-18-HT*	18 (457)	48 (1219)	30 (762)	72 (1829)	42 (1067)	96 (2438)	54 (1372)	120 (3048)
	24	(609)	(Prefix)-06-24-HT*	18 (457)	54 (1372)	30 (762)	78 (1981)	42 (1067)	102 (2591)	54 (1372)	126 (3200)
	30	(762)	(Prefix)-06-30-HT*	18 (457)	60 (1524)	30 (762)	84 (2134)	42 (1067)	108 (2743)	54 (1372)	132 (3353)
	36	(914)	(Prefix)-06-36-HT*	18 (457)	66 (1676)	30 (762)	90 (2286)	42 (1067)	114 (2895)	54 (1372)	138 (3503)
	42	(1067)	(Prefix)-06-42-HT*	18 (457)	72 (1829)	30 (762)	96 (2438)	42 (1067)	120 (3048)	54 (1372)	144 (3658)
9 (228)	12	(305)	(Prefix)-09-12-HT*	19½ (496)	42 (1067)	31½ (800)	66 (1676)	43½ (1105)	90 (2286)	55½ (1410)	114 (2895)
	18	(457)	(Prefix)-09-18-HT*	19½ (496)	48 (1219)	31½ (800)	72 (1829)	43½ (1105)	96 (2438)	55½ (1410)	120 (3048)
	24	(609)	(Prefix)-09-24-HT*	19½ (496)	54 (1372)	31½ (800)	78 (1981)	43½ (1105)	102 (2591)	55½ (1410)	126 (3200)
	30	(762)	(Prefix)-09-30-HT*	19½ (496)	60 (1524)	31½ (800)	84 (2134)	43½ (1105)	108 (2743)	55½ (1410)	132 (3353)
	36	(914)	(Prefix)-09-36-HT*	19½ (496)	66 (1676)	31½ (800)	90 (2286)	43½ (1105)	114 (2895)	55½ (1410)	138 (3503)
	42	(1067)	(Prefix)-09-42-HT*	19½ (496)	72 (1829)	31½ (800)	96 (2438)	43½ (1105)	120 (3048)	55½ (1410)	144 (3658)
12 (305)	18	(457)	(Prefix)-12-18-HT*	21 (533)	48 (1219)	33 (838)	72 (1829)	45 (1143)	96 (2438)	57 (1448)	120 (3048)
	24	(609)	(Prefix)-12-24-HT*	21 (533)	54 (1372)	33 (838)	78 (1981)	45 (1143)	102 (2591)	57 (1448)	126 (3200)
	30	(762)	(Prefix)-12-30-HT*	21 (533)	60 (1524)	33 (838)	84 (2134)	45 (1143)	108 (2743)	57 (1448)	132 (3353)
	36	(914)	(Prefix)-12-36-HT*	21 (533)	66 (1676)	33 (838)	90 (2286)	45 (1143)	114 (2895)	57 (1448)	138 (3503)
	42	(1067)	(Prefix)-12-42-HT*	21 (533)	72 (1829)	33 (838)	96 (2438)	45 (1143)	120 (3048)	57 (1448)	144 (3658)
18 (457)	24	(609)	(Prefix)-18-24-HT*	24 (609)	54 (1372)	36 (914)	78 (1981)	48 (1219)	102 (2591)	60 (1524)	126 (3200)
	30	(762)	(Prefix)-18-30-HT*	24 (609)	60 (1524)	36 (914)	84 (2134)	48 (1219)	108 (2743)	60 (1524)	132 (3353)
	36	(914)	(Prefix)-18-36-HT*	24 (609)	66 (1676)	36 (914)	90 (2286)	48 (1219)	114 (2895)	60 (1524)	138 (3503)
	42	(1067)	(Prefix)-18-42-HT*	24 (609)	72 (1829)	36 (914)	96 (2438)	48 (1219)	120 (3048)	60 (1524)	144 (3658)
24 (609)	30	(762)	(Prefix)-24-30-HT*	27 (686)	60 (1524)	39 (991)	84 (2134)	51 (1295)	108 (2743)	63 (1600)	132 (3353)
	36	(914)	(Prefix)-24-36-HT*	27 (686)	66 (1676)	39 (991)	90 (2286)	51 (1295)	114 (2895)	63 (1600)	138 (3503)
	42	(1067)	(Prefix)-24-42-HT*	27 (686)	72 (1829)	39 (991)	96 (2438)	51 (1295)	120 (3048)	63 (1600)	144 (3658)
30 (762)	36	(914)	(Prefix)-30-36-HT*	30 (762)	66 (1676)	42 (1067)	90 (2286)	54 (1372)	114 (2895)	66 (1676)	138 (3503)
	42	(1067)	(Prefix)-30-42-HT*	30 (762)	72 (1829)	42 (1067)	96 (2438)	54 (1372)	120 (3048)	66 (1676)	144 (3658)
36 (914)	42	(1067)	(Prefix)-36-42-HT*	33 (838)	72 (1829)	45 (1143)	96 (2438)	57 (1448)	120 (3048)	69 (1753)	144 (3658)

(Prefix) See page L-3 for catalog number prefix.

Width dimensions are to inside wall. For aluminum fittings add 1.5 inches (38mm) for total outside width.

Manufacturing tolerances apply to all dimensions.

All dimensions in parentheses are millimeters unless otherwise specified.

Horizontal Expanding/Reducing Cross (HX) 3 pair splice plates with hardware included.

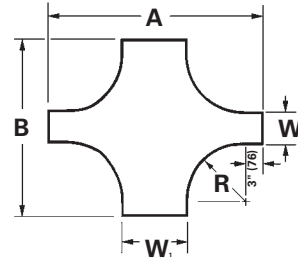
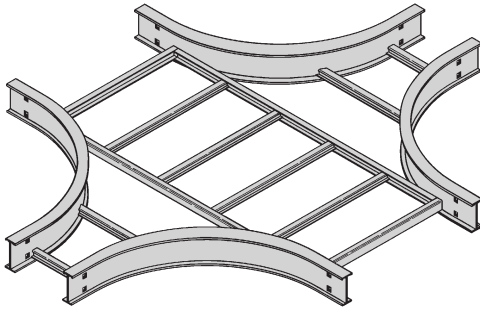

Prefix - 36 - 18 HX 24

Radius
Fitting
Width W₂
Width W₁

To complete catalog number, insert fitting prefix.

Tray Width		* Insert Radius (12", 24", 36", or 48") Catalog No.	12" Radius		24" Radius		36" Radius		48" Radius	
W1 in. mm	W2 in. mm		A in. mm	B in. mm	A in. mm	B in. mm	A in. mm	B in. mm	A in. mm	B in. mm
9 (228)	6 (152)	(Prefix)-09-06-HX*	39 (991)	36 (914)	63 1600	60 (1524)	87 (2210)	84 (2134)	111 2819	108 (2743)
12 (305)	6 (152)	(Prefix)-12-06-HX*	42 (1067)	36 (914)	66 (1676)	60 (1524)	90 (2286)	84 (2134)	114 (2895)	108 (2743)
	9 (228)	(Prefix)-12-09-HX*	42 (1067)	39 (991)	66 (1676)	63 (1600)	90 (2286)	87 (2210)	114 (2895)	111 (2819)
18 (457)	6 (152)	(Prefix)-18-06-HX*	48 (1219)	36 (914)	72 (1829)	60 (1524)	96 (2438)	84 (2134)	120 (3048)	108 (2743)
	9 (228)	(Prefix)-18-09-HX*	48 (1219)	39 (991)	72 (1829)	63 (1600)	96 (2438)	87 (2210)	120 (3048)	111 (2819)
	12 (305)	(Prefix)-18-12-HX*	48 (1219)	42 (1067)	72 (1829)	66 (1676)	96 (2438)	90 (2286)	120 (3048)	114 (2895)
24 (609)	6 (152)	(Prefix)-24-06-HX*	54 (1372)	36 (914)	78 (1981)	60 (1524)	102 (2591)	84 (2134)	126 (3200)	108 (2743)
	9 (228)	(Prefix)-24-09-HX*	54 (1372)	39 (991)	78 (1981)	63 (1600)	102 (2591)	87 (2210)	126 (3200)	111 (2819)
	12 (305)	(Prefix)-24-12-HX*	54 (1372)	42 (1067)	78 (1981)	66 (1676)	102 (2591)	90 (2286)	126 (3200)	114 (2895)
	18 (457)	(Prefix)-24-18-HX*	54 (1372)	48 (1219)	78 (1981)	72 (1829)	102 (2591)	96 (2438)	126 (3200)	120 (3048)
30 (762)	6 (152)	(Prefix)-30-06-HX*	60 (1524)	36 (914)	84 (2134)	60 (1524)	108 (2743)	84 (2134)	132 (3353)	108 (2743)
	9 (228)	(Prefix)-30-09-HX*	60 (1524)	39 (991)	84 (2134)	63 (1600)	108 (2743)	87 (2210)	132 (3353)	111 (2819)
	12 (305)	(Prefix)-30-12-HX*	60 (1524)	42 (1067)	84 (2134)	66 (1676)	108 (2743)	90 (2286)	132 (3353)	114 (2895)
	18 (457)	(Prefix)-30-18-HX*	60 (1524)	48 (1219)	84 (2134)	72 (1829)	108 (2743)	96 (2438)	132 (3353)	120 (3048)
	24 (609)	(Prefix)-30-24-HX*	60 (1524)	54 (1372)	84 (2134)	78 (1981)	108 (2743)	102 (2591)	132 (3353)	126 (3200)
36 (914)	6 (152)	(Prefix)-36-06-HX*	66 (1676)	36 (914)	90 (2286)	60 (1524)	114 (2895)	84 (2134)	138 (3505)	108 (2743)
	9 (228)	(Prefix)-36-09-HX*	66 (1676)	39 (991)	90 (2286)	63 (1600)	114 (2895)	87 (2210)	138 (3505)	111 (2819)
	12 (305)	(Prefix)-36-12-HX*	66 (1676)	42 (1067)	90 (2286)	66 (1676)	114 (2895)	90 (2286)	138 (3505)	114 (2895)
	18 (457)	(Prefix)-36-18-HX*	66 (1676)	48 (1219)	90 (2286)	72 (1829)	114 (2895)	96 (2438)	138 (3505)	120 (3048)
	24 (609)	(Prefix)-36-24-HX*	66 (1676)	54 (1372)	90 (2286)	78 (1981)	114 (2895)	102 (2591)	138 (3505)	126 (3200)
42 (1067)	30 (762)	(Prefix)-36-30-HX*	66 (1676)	60 (1524)	90 (2286)	84 (2134)	114 (2895)	108 (2743)	138 (3505)	132 (3353)
	6 (152)	(Prefix)-42-06-HX*	72 (1829)	36 (914)	96 (2438)	60 (1524)	120 (3048)	84 (2134)	144 (3658)	108 (2743)
	9 (228)	(Prefix)-42-09-HX*	72 (1829)	39 (991)	96 (2438)	63 (1600)	120 (3048)	87 (2210)	144 (3658)	111 (2819)
	12 (305)	(Prefix)-42-12-HX*	72 (1829)	42 (1067)	96 (2438)	66 (1676)	120 (3048)	90 (2286)	144 (3658)	114 (2895)
	18 (457)	(Prefix)-42-18-HX*	72 (1829)	48 (1219)	96 (2438)	72 (1829)	120 (3048)	96 (2438)	144 (3658)	120 (3048)
	24 (609)	(Prefix)-42-24-HX*	72 (1829)	54 (1372)	96 (2438)	78 (1981)	120 (3048)	102 (2591)	144 (3658)	126 (3200)
30 (762)	30 (762)	(Prefix)-42-30-HX*	72 (1829)	60 (1524)	96 (2438)	84 (2134)	120 (3048)	108 (2743)	144 (3658)	132 (3353)
	36 (914)	(Prefix)-42-36-HX*	72 (1829)	66 (1676)	96 (2438)	90 (2286)	120 (3048)	114 (2895)	144 (3658)	138 (3505)

(Prefix) See page L-3 for catalog number prefix.

Width dimensions are to inside wall. For aluminum fittings add 1.5 inches (38mm) for total outside width.

Manufacturing tolerances apply to all dimensions.

All dimensions in parentheses are millimeters unless otherwise specified.

Horizontal Wye (HYL, HYR)

2 pair splice plates with hardware included.

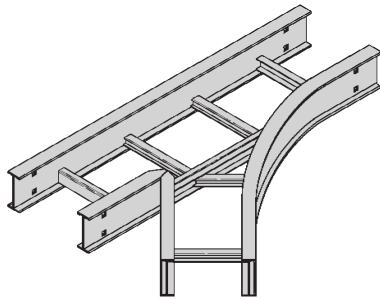

Left Hand Wye - HYL

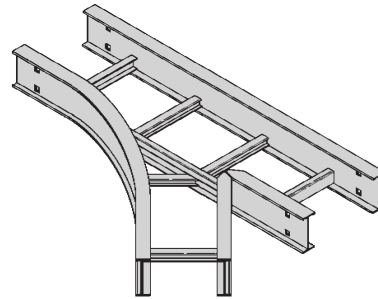

Right Hand Wye - HYR

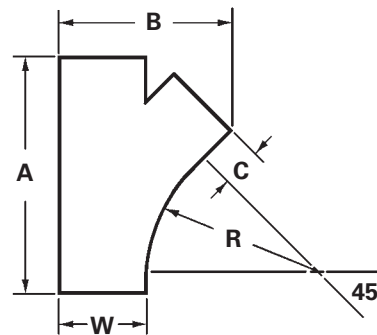
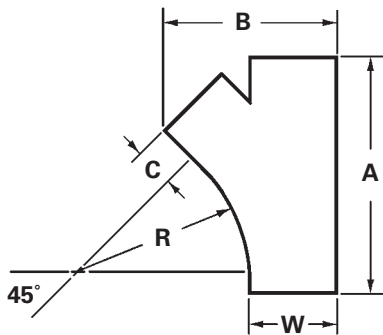

R = Radius

Series 2, 3, 4, & 5 Fittings

Bend Radius in. mm	Tray Width in. mm	Left Hand Wye Catalog No.	Right Hand Wye Catalog No.	A		B		C	
				in.	mm	in.	mm	in.	mm
24 (609)	6 (152)	(Prefix)-06-HYL	(Prefix)-06-HYR	28 ⁷ / ₁₆	(722)	15 ³ / ₁₆	(386)	3 ¹ / ₁₆	(77)
	9 (228)	(Prefix)-09-HYL	(Prefix)-09-HYR	32 ¹¹ / ₁₆	(831)	20 ⁵ / ₁₆	(516)	6 ¹ / ₁₆	(154)
	12 (305)	(Prefix)-12-HYL	(Prefix)-12-HYR	36 ¹⁵ / ₁₆	(938)	25 ⁷ / ₁₆	(646)	9 ¹ / ₁₆	(231)
	18 (457)	(Prefix)-18-HYL	(Prefix)-18-HYR	45 ³ / ₈	(1153)	35 ¹³ / ₁₆	(910)	15 ¹ / ₁₆	(383)
	24 (609)	(Prefix)-24-HYL	(Prefix)-24-HYR	53 ⁷ / ₈	(1368)	45 ¹⁵ / ₁₆	(1167)	21 ¹ / ₁₆	(535)
	30 (762)	(Prefix)-30-HYL	(Prefix)-30-HYR	62 ³ / ₈	(1585)	56 ³ / ₁₆	(1427)	27 ¹ / ₁₆	(688)
	36 (914)	(Prefix)-36-HYL	(Prefix)-36-HYR	70 ⁷ / ₈	(1800)	66 ⁷ / ₁₆	(1687)	33 ¹ / ₁₆	(840)
42 (1067)	(Prefix)-42-HYL	(Prefix)-42-HYR	79 ³ / ₈	(2016)	76 ⁵ / ₈	(1946)	39 ¹ / ₁₆	(992)	

(Prefix) See page L-3 for catalog number prefix.

Width dimensions are to inside wall. For aluminum fittings add 1.5 inches (38mm) for total outside width.

Manufacturing tolerances apply to all dimensions.

All dimensions in parentheses are millimeters unless otherwise specified.

Vertical Bend 90° (VO, VI)
1 pair splice plates with hardware included.

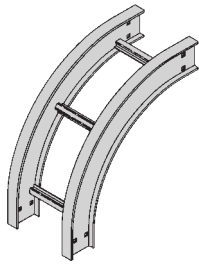

**90° Vertical Outside
- VO**

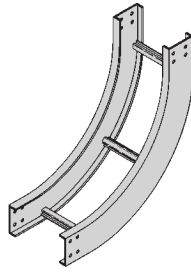
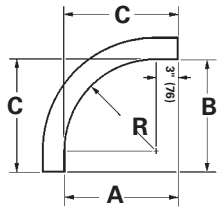

**90° Vertical Inside
- VI**

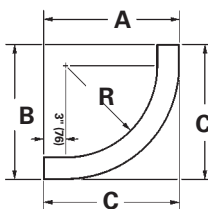

Bend Radius R	Tray Width Insert	(*) Insert "VO" for Vert. Outside Bend "VI" for Vert. Inside Bend Catalog No.	VO Side Rail Height 4" - 7"			VI Side Rail Height													
			4" - 7"			4"			5"			6"			7"				
			in./(mm)			in./(mm)			in./(mm)			in./(mm)			in./(mm)				
in./(mm)	in. (mm)		A	B	C	A	B	C	A	B	C	A	B	C	A	B	C		
12 (305)	6 (152)	(Prefix)-06-90(*)12																	
	9 (228)	(Prefix)-09-90(*)12																	
	12 (305)	(Prefix)-12-90(*)12																	
	18 (457)	(Prefix)-18-90(*)12	15	15	15	19	19	19	20	20	20	21	21	21	22	22	22	22	
	24 (609)	(Prefix)-24-90(*)12	(381)	(381)	(381)	(483)	(483)	(483)	(508)	(508)	(508)	(533)	(533)	(533)	(559)	(559)	(559)	(559)	
	30 (762)	(Prefix)-30-90(*)12																	
	36 (914)	(Prefix)-36-90(*)12																	
42 (1067)	(Prefix)-42-90(*)12																		
24 (609)	6 (152)	(Prefix)-06-90(*)24																	
	9 (228)	(Prefix)-09-90(*)24																	
	12 (305)	(Prefix)-12-90(*)24																	
	18 (457)	(Prefix)-18-90(*)24	27	27	27	31	31	31	32	32	32	33	33	33	34	34	34	34	
	24 (609)	(Prefix)-24-90(*)24	(686)	(686)	(686)	(787)	(787)	(787)	(813)	(813)	(813)	(838)	(838)	(838)	(864)	(864)	(864)	(864)	
	30 (762)	(Prefix)-30-90(*)24																	
	36 (914)	(Prefix)-36-90(*)24																	
42 (1067)	(Prefix)-42-90(*)24																		
36 (914)	6 (152)	(Prefix)-06-90(*)36																	
	9 (228)	(Prefix)-09-90(*)36																	
	12 (305)	(Prefix)-12-90(*)36																	
	18 (457)	(Prefix)-18-90(*)36	39	39	39	43	43	43	44	44	44	45	45	45	46	46	46	46	
	24 (609)	(Prefix)-24-90(*)36	(991)	(991)	(991)	(1092)	(1092)	(1092)	(1118)	(1118)	(1118)	(1143)	(1143)	(1143)	(1168)	(1168)	(1168)	(1168)	
	30 (762)	(Prefix)-30-90(*)36																	
	36 (914)	(Prefix)-36-90(*)36																	
42 (1067)	(Prefix)-42-90(*)36																		
48 (1219)	6 (152)	(Prefix)-06-90(*)48																	
	9 (228)	(Prefix)-09-90(*)48																	
	12 (305)	(Prefix)-12-90(*)48																	
	18 (457)	(Prefix)-18-90(*)48	51	51	51	55	55	55	56	56	56	57	57	57	58	58	58	58	
	24 (609)	(Prefix)-24-90(*)48	(1295)	(1295)	(1295)	(1397)	(1397)	(1397)	(1422)	(1422)	(1422)	(1448)	(1448)	(1448)	(1473)	(1473)	(1473)	(1473)	
	30 (762)	(Prefix)-30-90(*)48																	
	36 (914)	(Prefix)-36-90(*)48																	
42 (1067)	(Prefix)-42-90(*)48																		

(Prefix) See page L-3 for catalog number prefix.

Width dimensions are to inside wall. For aluminum fittings add 1.5 inches (38mm) for total outside width.

Manufacturing tolerances apply to all dimensions.

All dimensions in parentheses are millimeters unless otherwise specified.

Series 2, 3, 4, & 5 - Fittings

Vertical Bend 60° (VO, VI)

1 pair splice plates with hardware included.

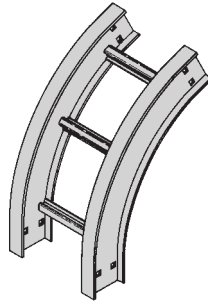

60° Vertical Outside - VO

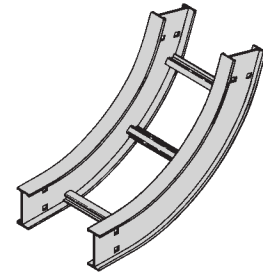

60° Vertical Inside - VI

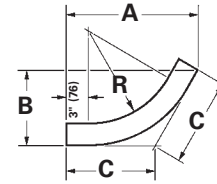
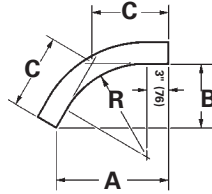

Bend Radius R in./(mm)	Tray Width Insert in. (mm)	(*) Insert "VO" for Vert. Outside Bend "VI" for Vert. Inside Bend Catalog No.	VO Side Rail Height 4" - 7"			VI Side Rail Height												
			in./(mm)			4"			5"			6"			7"			
			A	B	C	A	B	C	A	B	C	A	B	C	A	B	C	
12 (305)	6 (152)	(Prefix)-06-60(*)12																
	9 (228)	(Prefix)-09-60(*)12																
	12 (305)	(Prefix)-12-60(*)12																
	18 (457)	(Prefix)-18-60(*)12	14 ⁷ / ₈	8 ⁵ / ₈	9 ¹⁵ / ₁₆	18 ³ / ₈	10 ⁷ / ₈	12 ¹ / ₄	19 ¹ / ₄	11 ¹ / ₈	12 ¹³ / ₁₆	20 ¹ / ₁₆	11 ⁵ / ₈	13 ³ / ₈	21 ¹⁵ / ₁₆	12 ¹ / ₈	14	
	24 (609)	(Prefix)-24-60(*)12	(378)	(219)	(253)	(467)	(270)	(311)	(489)	(283)	(326)	(510)	(296)	(340)	(557)	(308)	(356)	
	30 (762)	(Prefix)-30-60(*)12																
	36 (914)	(Prefix)-36-60(*)12																
42 (1067)	(Prefix)-42-60(*)12																	
24 (609)	6 (152)	(Prefix)-06-60(*)24																
	9 (228)	(Prefix)-09-60(*)24																
	12 (305)	(Prefix)-12-60(*)24																
	18 (457)	(Prefix)-18-60(*)24	25 ⁵ / ₁₆	14 ⁵ / ₈	16 ⁷ / ₈	28 ³ / ₄	16 ⁵ / ₈	19 ³ / ₁₆	29 ⁵ / ₈	17 ¹ / ₈	19 ³ / ₄	30 ¹ / ₂	17 ⁵ / ₈	20 ⁵ / ₁₆	31 ³ / ₈	18 ¹ / ₈	20 ⁷ / ₈	
	24 (609)	(Prefix)-24-60(*)24	(643)	(372)	(428)	(730)	(422)	(488)	(753)	(435)	(502)	(775)	(448)	(516)	(797)	(461)	(530)	
	30 (762)	(Prefix)-30-60(*)24																
	36 (914)	(Prefix)-36-60(*)24																
42 (1067)	(Prefix)-42-60(*)24																	
36 (914)	6 (152)	(Prefix)-06-60(*)36																
	9 (228)	(Prefix)-09-60(*)36																
	12 (305)	(Prefix)-12-60(*)36																
	18 (457)	(Prefix)-18-60(*)36	35 ¹¹ / ₁₆	20 ⁵ / ₈	23 ¹³ / ₁₆	39 ¹ / ₈	22 ⁵ / ₈	26 ¹ / ₈	40	23 ¹ / ₈	26 ¹¹ / ₁₆	40 ⁷ / ₈	23 ⁵ / ₈	27 ¹ / ₄	41 ³ / ₄	24 ¹ / ₈	27 ¹³ / ₁₆	
	24 (609)	(Prefix)-24-60(*)36	(907)	(524)	(605)	(994)	(575)	(663)	(1016)	(587)	(687)	(1038)	(600)	(692)	(1060)	(613)	(706)	
	30 (762)	(Prefix)-30-60(*)36																
	36 (914)	(Prefix)-36-60(*)36																
42 (1067)	(Prefix)-42-60(*)36																	
48 (1219)	6 (152)	(Prefix)-06-60(*)48																
	9 (228)	(Prefix)-09-60(*)48																
	12 (305)	(Prefix)-12-60(*)48																
	18 (457)	(Prefix)-18-60(*)48	46 ¹ / ₁₆	26 ⁵ / ₈	30 ¹¹ / ₁₆	49 ⁹ / ₁₆	28 ⁵ / ₈	33	50 ³ / ₈	29 ¹ / ₈	33 ⁵ / ₈	51 ¹ / ₄	29 ⁵ / ₈	34 ³ / ₁₆	52 ¹ / ₈	30 ¹ / ₈	34 ³ / ₄	
	24 (609)	(Prefix)-24-60(*)48	(1170)	(676)	(780)	(1259)	(727)	(838)	(1280)	(740)	(854)	(1302)	(753)	(868)	(1324)	(765)	(883)	
	30 (762)	(Prefix)-30-60(*)48																
	36 (914)	(Prefix)-36-60(*)48																
42 (1067)	(Prefix)-42-60(*)48																	

(Prefix) See page L-3 for catalog number prefix.

Width dimensions are to inside wall. For aluminum fittings add 1.5 inches (38mm) for total outside width.

Manufacturing tolerances apply to all dimensions.

All dimensions in parentheses are millimeters unless otherwise specified.

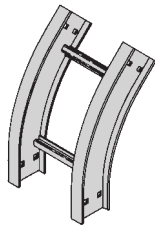

45° Vertical Outside -VO

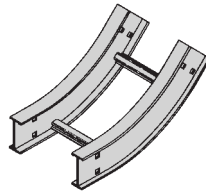

45° Vertical Inside -VI

Vertical Bend 45° (VO, VI)

1 pair splice plates with hardware included.

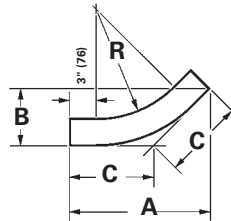
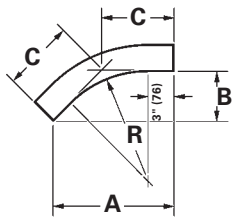

Bend Radius R	Tray Width Insert	(*) Insert "VO" for Vert. Outside Bend "VI" for Vert. Inside Bend Catalog No.	VO Side Rail Height 4" - 7"			VI Side Rail Height											
			in./(mm)			4"			5"			6"			7"		
			A	B	C	A	B	C	A	B	C	A	B	C	A	B	C
12 (305)	6 (152)	(Prefix)-06-45(*)12															
	9 (228)	(Prefix)-09-45(*)12															
	12 (305)	(Prefix)-12-45(*)12															
	18 (457)	(Prefix)-18-45(*)12	13 ⁵ / ₈	5 ⁵ / ₈	8	16 ⁷ / ₁₆	6 ¹³ / ₁₆	9 ⁵ / ₈	17 ¹ / ₈	7 ¹ / ₈	10 ¹ / ₁₆	17 ⁷ / ₈	7 ³ / ₈	10 ⁷ / ₁₆	18 ⁹ / ₁₆	7 ¹¹ / ₁₆	10 ⁷ / ₈
	24 (609)	(Prefix)-24-45(*)12	(346)	(143)	(203)	(417)	(173)	(245)	(435)	(181)	(256)	(454)	(188)	(265)	(471)	(195)	(2176)
	30 (762)	(Prefix)-30-45(*)12															
	36 (914)	(Prefix)-36-45(*)12															
42 (1067)	(Prefix)-42-45(*)12																
24 (609)	6 (152)	(Prefix)-06-45(*)24															
	9 (228)	(Prefix)-09-45(*)24															
	12 (305)	(Prefix)-12-45(*)24															
	18 (457)	(Prefix)-18-45(*)24	22 ¹ / ₁₆	9 ¹ / ₈	12 ¹⁵ / ₁₆	24 ¹⁵ / ₁₆	10 ⁵ / ₁₆	14 ⁵ / ₈	25 ⁵ / ₈	10 ⁵ / ₈	15	26 ⁵ / ₁₆	10 ¹⁵ / ₁₆	15 ⁷ / ₁₆	27 ¹ / ₁₆	11 ³ / ₁₆	15 ¹³ / ₁₆
	24 (609)	(Prefix)-24-45(*)24	(561)	(232)	(329)	(634)	(262)	(372)	(651)	(270)	(381)	(668)	(278)	(392)	(687)	(284)	(402)
	30 (762)	(Prefix)-30-45(*)24															
	36 (914)	(Prefix)-36-45(*)24															
42 (1067)	(Prefix)-42-45(*)24																
36 (914)	6 (152)	(Prefix)-06-45(*)36															
	9 (228)	(Prefix)-09-45(*)36															
	12 (305)	(Prefix)-12-45(*)36															
	18 (457)	(Prefix)-18-45(*)36	30 ⁹ / ₁₆	12 ¹¹ / ₁₆	17 ¹⁵ / ₁₆	33 ³ / ₈	13 ¹³ / ₁₆	19 ⁹ / ₁₆	34 ¹ / ₈	14 ¹ / ₈	20	34 ¹³ / ₁₆	14 ⁷ / ₁₆	20 ³ / ₈	35 ¹ / ₂	14 ¹¹ / ₁₆	20 ¹³ / ₁₆
	24 (609)	(Prefix)-24-45(*)36	(776)	(323)	(456)	(848)	(351)	(497)	(867)	(359)	(508)	(885)	(367)	(518)	(902)	(284)	(402)
	30 (762)	(Prefix)-30-45(*)36															
	36 (914)	(Prefix)-36-45(*)36															
42 (1067)	(Prefix)-42-45(*)36																
48 (1219)	6 (152)	(Prefix)-06-45(*)48															
	9 (228)	(Prefix)-09-45(*)48															
	12 (305)	(Prefix)-12-45(*)48															
	18 (457)	(Prefix)-18-45(*)48	39 ¹ / ₁₆	16 ³ / ₁₆	22 ⁷ / ₈	41 ⁷ / ₈	17 ³ / ₈	24 ⁹ / ₁₆	42 ⁵ / ₈	17 ³ / ₈	24 ¹⁵ / ₁₆	43 ⁵ / ₁₆	17 ¹⁵ / ₁₆	25 ³ / ₈	44	18 ¹ / ₄	25 ¹³ / ₁₆
	24 (609)	(Prefix)-24-45(*)48	(992)	(411)	(581)	(1064)	(441)	(624)	(1083)	(448)	(633)	(1100)	(456)	(645)	(1118)	(464)	(656)
	30 (762)	(Prefix)-30-45(*)48															
	36 (914)	(Prefix)-36-45(*)48															
42 (1067)	(Prefix)-42-45(*)48																

(Prefix) See page L-3 for catalog number prefix.

Width dimensions are to inside wall. For aluminum fittings add 1.5 inches (38mm) for total outside width. Manufacturing tolerances apply to all dimensions.

All dimensions in parentheses are millimeters unless otherwise specified.

Series 2, 3, 4, & 5 - Fittings

Vertical Bend 30° (VO, VI)

1 pair splice plates with hardware included.

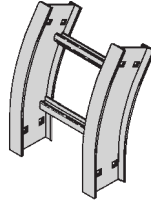

30° Vertical Outside -VO

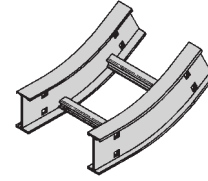

30° Vertical Inside -VI

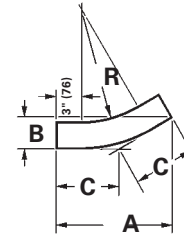
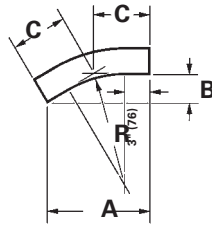

Bend Radius R in./(mm)	Tray Width Insert in. (mm)	(*) Insert "VO" for Vert. Outside Bend "VI" for Vert. Inside Bend Catalog No.	VO Side Rail Height 4" - 7"			VI Side Rail Height											
			in./(mm)			4"			5"			6"			7"		
			A	B	C	A	B	C	A	B	C	A	B	C	A	B	C
12 (305)	6 (152)	(Prefix)-06-30(*)12															
	9 (228)	(Prefix)-09-30(*)12															
	12 (305)	(Prefix)-12-30(*)12															
	18 (457)	(Prefix)-18-30(*)12	11 ⁵ / ₈	3 ¹ / ₈	6 ³ / ₁₆	13 ⁵ / ₈	3 ⁵ / ₈	7 ⁹ / ₁₆	14 ¹ / ₈	3 ³ / ₄	7 ⁹ / ₁₆	14 ⁵ / ₈	3 ¹⁵ / ₁₆	7 ¹³ / ₁₆	15 ¹ / ₈	4 ¹ / ₁₆	8 ¹ / ₁₆
	24 (609)	(Prefix)-24-30(*)12	(296)	(79)	(157)	(346)	(92)	(186)	(359)	(95)	(192)	(372)	(100)	(199)	(384)	(103)	(205)
	30 (762)	(Prefix)-30-30(*)12															
	36 (914)	(Prefix)-36-30(*)12															
42 (1067)	(Prefix)-42-30(*)12																
24 (609)	6 (152)	(Prefix)-06-30(*)24															
	9 (228)	(Prefix)-09-30(*)24															
	12 (305)	(Prefix)-12-30(*)24															
	18 (457)	(Prefix)-18-30(*)24	17 ⁵ / ₈	4 ¹¹ / ₁₆	9 ⁷ / ₁₆	19 ⁵ / ₈	5 ¹ / ₄	10 ¹ / ₂	20 ¹ / ₈	5 ³ / ₈	10 ³ / ₄	20 ⁵ / ₈	5 ¹ / ₂	11 ¹ / ₁₆	21 ¹ / ₈	5 ⁵ / ₈	11 ⁵ / ₁₆
	24 (609)	(Prefix)-24-30(*)24	(448)	(120)	(240)	(499)	(133)	(267)	(511)	(137)	(273)	(524)	(140)	(282)	(537)	(143)	(287)
	30 (762)	(Prefix)-30-30(*)24															
	36 (914)	(Prefix)-36-30(*)24															
42 (1067)	(Prefix)-42-30(*)24																
36 (914)	6 (152)	(Prefix)-06-30(*)36															
	9 (228)	(Prefix)-09-30(*)36															
	12 (305)	(Prefix)-12-30(*)36															
	18 (457)	(Prefix)-18-30(*)36	23 ⁵ / ₈	6 ⁵ / ₁₆	12 ⁵ / ₈	25 ⁵ / ₈	6 ⁷ / ₈	13 ¹¹ / ₁₆	26 ¹ / ₈	7	14	26 ⁵ / ₈	7 ¹ / ₈	14 ¹ / ₄	27 ¹ / ₈	7 ¹ / ₄	14 ¹ / ₂
	24 (609)	(Prefix)-24-30(*)36	(600)	(160)	(321)	(651)	(174)	(348)	(663)	(175)	(356)	(676)	(181)	(362)	(689)	(184)	(287)
	30 (762)	(Prefix)-30-30(*)36															
	36 (914)	(Prefix)-36-30(*)36															
42 (1067)	(Prefix)-42-30(*)36																
48 (1219)	6 (152)	(Prefix)-06-30(*)48															
	9 (228)	(Prefix)-09-30(*)48															
	12 (305)	(Prefix)-12-30(*)48															
	18 (457)	(Prefix)-18-30(*)48	29 ⁵ / ₈	7 ¹⁵ / ₁₆	15 ⁷ / ₈	31 ⁵ / ₈	8 ⁷ / ₁₆	16 ¹⁵ / ₁₆	32 ¹ / ₈	8 ⁵ / ₈	17 ⁹ / ₁₆	32 ⁵ / ₈	8 ³ / ₄	17 ¹ / ₂	33 ¹ / ₈	8 ⁷ / ₈	17 ³ / ₄
	24 (609)	(Prefix)-24-30(*)48	(753)	(202)	(403)	(803)	(214)	(430)	(816)	(219)	(437)	(829)	(222)	(445)	(842)	(226)	(451)
	30 (762)	(Prefix)-30-30(*)48															
	36 (914)	(Prefix)-36-30(*)48															
42 (1067)	(Prefix)-42-30(*)48																

(Prefix) See page L-3 for catalog number prefix.

Width dimensions are to inside wall. For aluminum fittings add 1.5 inches (38mm) for total outside width.

Manufacturing tolerances apply to all dimensions.

All dimensions in parentheses are millimeters unless otherwise specified.

Vertical Tee Up/Down (VTU/VT)
2 pair splice plates with hardware included.

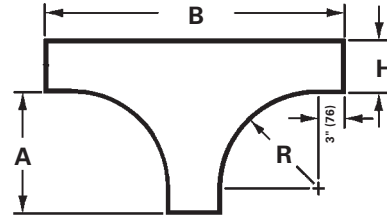
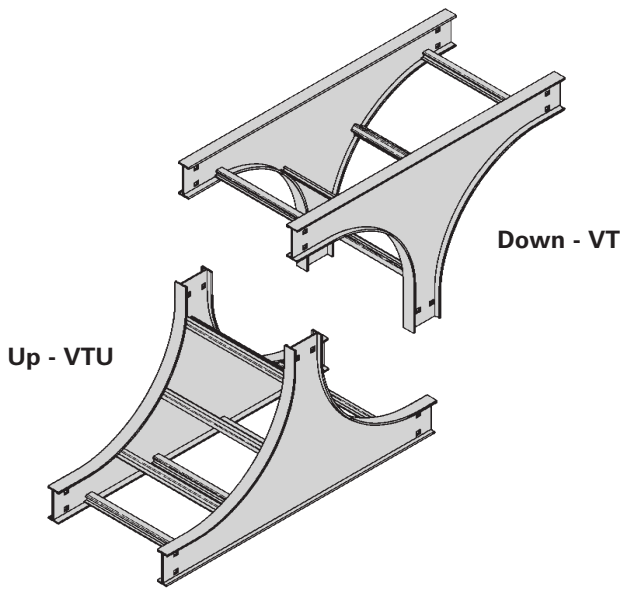

Bend Radius R in./(mm)	Tray Width in. mm	Vertical Tee Down Catalog No.	Vertical Tee Up Catalog No.	Side Rail Height "H"							
				4"		5"		6"		7"	
				A in./(mm)	B in./(mm)	A in./(mm)	B in./(mm)	A in./(mm)	B in./(mm)	A in./(mm)	B in./(mm)
12 (305)	6 (152)	(Prefix)-06-VT12	(Prefix)-06-VTU12								
	9 (228)	(Prefix)-09-VT12	(Prefix)-09-VTU12								
	12 (305)	(Prefix)-12-VT12	(Prefix)-12-VTU12								
	18 (457)	(Prefix)-18-VT12	(Prefix)-18-VTU12	15	34	15	35	15	36	15	37
	24 (609)	(Prefix)-24-VT12	(Prefix)-24-VTU12	(381)	(846)	(381)	(889)	(381)	(914)	(381)	(940)
	30 (762)	(Prefix)-30-VT12	(Prefix)-30-VTU12								
	36 (914)	(Prefix)-36-VT12	(Prefix)-36-VTU12								
42 (1067)	(Prefix)-42-VT12	(Prefix)-42-VTU12									
24 (609)	6 (152)	(Prefix)-06-VT24	(Prefix)-06-VTU24								
	9 (228)	(Prefix)-09-VT24	(Prefix)-09-VTU24								
	12 (305)	(Prefix)-12-VT24	(Prefix)-12-VTU24								
	18 (457)	(Prefix)-18-VT24	(Prefix)-18-VTU24	27	58	27	59	27	60	27	61
	24 (609)	(Prefix)-24-VT24	(Prefix)-24-VTU24	(6867)	(1473)	(686)	(1498)	(686)	(1524)	(686)	(1549)
	30 (762)	(Prefix)-30-VT24	(Prefix)-30-VTU24								
	36 (914)	(Prefix)-36-VT24	(Prefix)-36-VTU24								
42 (1067)	(Prefix)-42-VT24	(Prefix)-42-VTU24									
36 (914)	6 (152)	(Prefix)-06-VT36	(Prefix)-06-VTU36								
	9 (228)	(Prefix)-09-VT36	(Prefix)-09-VTU36								
	12 (305)	(Prefix)-12-VT36	(Prefix)-12-VTU36								
	18 (457)	(Prefix)-18-VT36	(Prefix)-18-VTU36	39	82	39	83	39	84	39	85
	24 (609)	(Prefix)-24-VT36	(Prefix)-24-VTU36	(991)	(2083)	(991)	(2108)	(991)	(2134)	(991)	(2159)
	30 (762)	(Prefix)-30-VT36	(Prefix)-30-VTU36								
	36 (914)	(Prefix)-36-VT36	(Prefix)-36-VTU36								
42 (1067)	(Prefix)-42-VT36	(Prefix)-42-VTU36									
48 (1219)	6 (152)	(Prefix)-06-VT48	(Prefix)-06-VTU48								
	9 (228)	(Prefix)-09-VT48	(Prefix)-09-VTU48								
	12 (305)	(Prefix)-12-VT48	(Prefix)-12-VTU48								
	18 (457)	(Prefix)-18-VT48	(Prefix)-18-VTU48	51	106	51	107	51	108	51	109
	24 (609)	(Prefix)-24-VT48	(Prefix)-24-VTU48	(1295)	(2692)	(1295)	(2718)	(1295)	(2743)	(1295)	(2769)
	30 (762)	(Prefix)-30-VT48	(Prefix)-30-VTU48								
	36 (914)	(Prefix)-36-VT48	(Prefix)-36-VTU48								
42 (1067)	(Prefix)-42-VT48	(Prefix)-42-VTU48									

Series 2, 3, 4, & 5 Fittings

(Prefix) See page L-3 for catalog number prefix.

Width dimensions are to inside wall. For aluminum fittings add 1.5 inches (38mm) for total outside width.

Manufacturing tolerances apply to all dimensions.

All dimensions in parentheses are millimeters unless otherwise specified.

Series 2, 3, 4, & 5 - Fittings

Cable Support Fittings (CSF)

1 pair splice plates with hardware included.

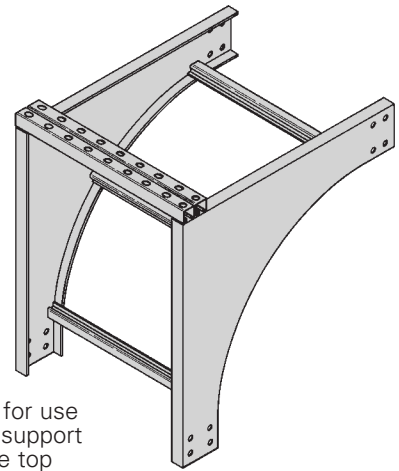
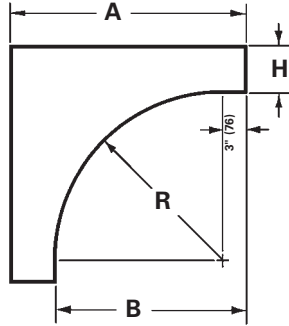

This fitting is recommended for use at the top of vertical runs to support the weight of the cables. The top cross brace is drilled for installing eyebolts, ordered separately.

Series 2, 3, 4, & 5 Fittings

Bend Radius R in./mm	Tray Width in. mm	Catalog No.	Side Rail Height "H"							
			4"		5"		6"		7"	
			A in./mm	B in./mm	A in./mm	B in./mm	A in./mm	B in./mm	A in./mm	B in./mm
12 (305)	6 152	(Prefix)-06-CSF12	19 (483)	15 (381)	20 (508)	15 (381)	21 (533)	15 (381)	22 (559)	15 (381)
	9 228	(Prefix)-09-CSF12								
	12 305	(Prefix)-12-CSF12								
	18 457	(Prefix)-18-CSF12								
	24 609	(Prefix)-24-CSF12								
	30 762	(Prefix)-30-CSF12								
	36 914	(Prefix)-36-CSF12								
42 1067	(Prefix)-42-CSF12									
24 (609)	6 152	(Prefix)-06-CSF24	31 (787)	27 (686)	32 (813)	27 (686)	33 (838)	27 (686)	34 (864)	27 (686)
	9 228	(Prefix)-09-CSF24								
	12 305	(Prefix)-12-CSF24								
	18 457	(Prefix)-18-CSF24								
	24 609	(Prefix)-24-CSF24								
	30 762	(Prefix)-30-CSF24								
	36 914	(Prefix)-36-CSF24								
42 1067	(Prefix)-42-CSF24									
36 (914)	6 152	(Prefix)-06-CSF36	43 (1092)	39 (991)	44 (1118)	39 (991)	45 (1143)	39 (991)	46 (1168)	39 (991)
	9 228	(Prefix)-09-CSF36								
	12 305	(Prefix)-12-CSF36								
	18 457	(Prefix)-18-CSF36								
	24 609	(Prefix)-24-CSF36								
	30 762	(Prefix)-30-CSF36								
	36 914	(Prefix)-36-CSF36								
42 1067	(Prefix)-42-CSF36									
48 (1219)	6 152	(Prefix)-06-CSF48	55 (1397)	51 (1295)	56 (1422)	51 (1295)	57 (1448)	51 (1295)	58 (1473)	51 (1295)
	9 228	(Prefix)-09-CSF48								
	12 305	(Prefix)-12-CSF48								
	18 457	(Prefix)-18-CSF48								
	24 609	(Prefix)-24-CSF48								
	30 762	(Prefix)-30-CSF48								
	36 914	(Prefix)-36-CSF48								
42 1067	(Prefix)-42-CSF48									

(Prefix) See page L-3 for catalog number prefix.

Width dimensions are to inside wall. For aluminum fittings add 1.5 inches (38mm) for total outside width.

Manufacturing tolerances apply to all dimensions.

All dimensions in parentheses are millimeters unless otherwise specified.

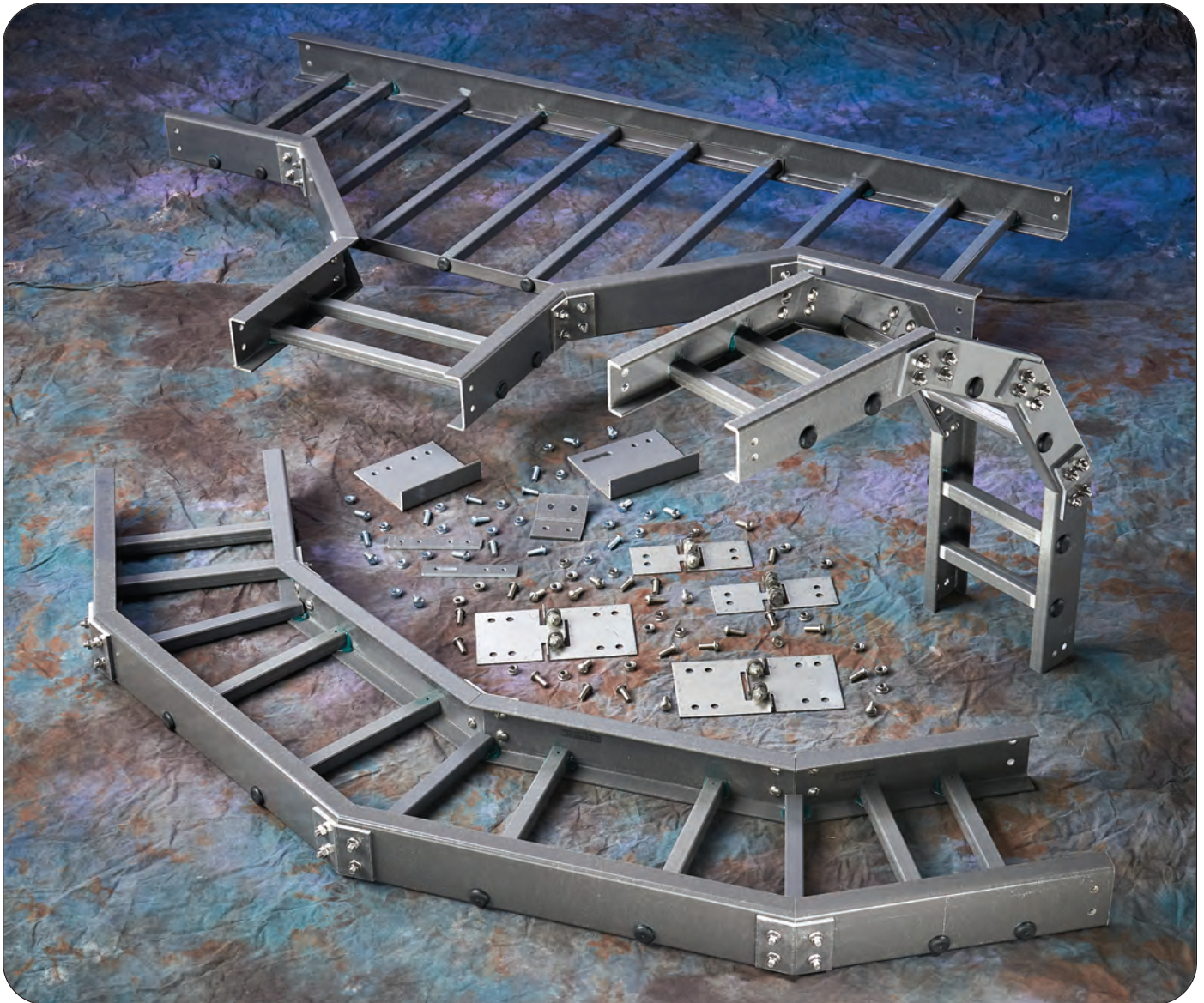

How The Service Advisor Works

We know that your time is important! That's why the color-coding system in this catalog is designed to help you select products that fit your service needs. Products are marked to indicate the typical lead time for orders of 50 pieces or less.

Customer: How do I select my straight sections, covers, or fittings so that I get the quickest turnaround?

Service Advisor: Each part of our selection chart is shown in colors. If any section of a part number is a different color, the part will typically ship with the longer lead time represented by the colors.

- Green = Fastest shipped items
- Black = Normal lead-time items
- Red = Normally long lead-time items

Example:

46	FV	-	09	-	24	-	144
●	●		●		●		●
3-5	15		3-5		3-5		3-5

Part will have a long lead time because of the FV material.

Changing the part number from 46FV to 46F will change the coding to black for all sections and reduce the lead time.

Fiberglass - Technical Data

Corrosion Guide

The information shown in this corrosion guide is based on full immersion laboratory tests and data generated from resin manufacturer's data. It should be noted that in some of the environments listed, splashes and spill situations may result in a more corrosive situation than indicated due to the evaporation of water. Regular wash down is recommended in these situations.

All data represents the best available information and is believed to be correct. The data should not be construed as a warranty of performance for that product as presented in these tables. User tests should be performed to determine suitability of service if there is any doubt or concern. Such variables as concentration, temperature, time and combined chemical effects of mixtures of chemicals make it impossible to specify the exact suitability of fiber reinforced plastics in all environments. We will be happy to supply material samples for testing. These recommendations should only be used as a guide and we do not take responsibility for design or suitability of materials for service intended. In no event will we be liable for any consequential or special damages for any defective material or workmanship including without limitation, labor charge, other expense or damage to properties resulting from loss of materials or profits or increased expenses of operations.

CHEMICAL ENVIRONMENT	POLYESTER		VINYL ESTER	
	Max Wt. %	Max Oper. Temp °F	Max Wt. %	Max Oper. Temp °F
Acetic Acid	10	190	10	210
Acetic Acid	50	125	50	180
Acetone	N/R	N/R	100	75
Aluminum Chloride	SAT	170	SAT	200
Aluminum Hydroxide	SAT	160	SAT	170
Aluminum Nitrate	SAT	150	SAT	170
Aluminum Sulfate	SAT	180	SAT	200
Ammonium Chloride	SAT	170	SAT	190
Ammonium Hydroxide	1	100	10	150
Ammonium Hydroxide	28	N/R	28	100
Ammonium Carbonate	N/R	N/R	SAT	150
Ammonium Bicarbonate	15	125	SAT	130
Ammonium Nitrate	SAT	160	SAT	190
Ammonium Persulfate	SAT	N/R	SAT	150
Ammonium Sulfate	SAT	170	SAT	200
Amyl Alcohol	ALL	N/R	ALL	90
Amyl Alcohol Vapor	-	140	-	120
Benzene	N/R	N/R	100	140
Benzene Sulfonic Acid	25	110	SAT	200
Benzoic Acid	SAT	150	SAT	200
Benzoyl Alcohol	100	N/R	100	N/R
Borax	SAT	170	SAT	200
Calcium Carbonate	SAT	170	SAT	200
Calcium Chloride	SAT	170	SAT	200
Calcium Hydroxide	25	70	25	165
Calcium Nitrate	SAT	180	SAT	200
Calcium Sulfate	SAT	180	SAT	200
Carbon Disulfide	N/R	N/R	N/R	N/R
Carbonic Acid	SAT	130	SAT	180
Carbon Dioxide Gas	-	200	-	200
Carbon Monoxide Gas	-	200	-	200
Carbon Tetrachloride	N/R	N/R	100	75
Chlorine, Dry Gas	-	140	-	170
Chlorine, Wet Gas	-	N/R	-	180
Chlorine Water	SAT	80	SAT	180

CHEMICAL ENVIRONMENT	POLYESTER		VINYL ESTER	
	Max Wt. %	Max Oper. Temp °F	Max Wt. %	Max Oper. Temp °F
Chromic Acid	5	70	10	120
Citric Acid	SAT	170	SAT	200
Copper Chloride	SAT	170	SAT	200
Copper Cyanide	SAT	170	SAT	200
Copper Nitrate	SAT	170	SAT	200
Crude Oil, Sour	100	170	100	200
Cyclohexane	N/R	N/R	N/R	N/R
Cyclohexane, Vapor	ALL	100	ALL	130
Diesel Fuel	100	160	100	180
Diethyl Ether	N/R	N/R	N/R	N/R
Dimethyl Phthalate	N/R	N/R	N/R	N/R
Ethanol	50	75	50	90
Ethyl Acetate	N/R	N/R	N/R	N/R
Ethylene Chloride	N/R	N/R	N/R	N/R
Ethylene Glycol	100	90	100	200
Fatty Acids	SAT	180	SAT	200
Ferric Chloride	SAT	170	SAT	200
Ferric Nitrate	SAT	170	SAT	200
Ferric Sulfate	SAT	170	SAT	200
Ferrous Chloride	SAT	170	SAT	200
Fluoboric Acid	N/R	N/R	SAT	165
Fluosilicic Acid	N/R	N/R	SAT	70
Formaldehyde	50	75	50	100
Formic Acid	N/R	N/R	50	100
Gasoline	100	80	100	150
Glucose	100	170	100	200
Glycerine	100	150	100	200
Heptane	100	110	100	120
Hexane	100	90	100	130
Hydrobromic Acid	50	120	50	120
Hydrochloric Acid	10	150	10	200
Hydrochloric Acid	20	140	20	190
Hydrochloric Acid	37	75	37	95
Hydrofluoric Acid	N/R	N/R	15	80
Hydrogen Bromide, Dry	100	190	100	200

-: No Information Available

N/R: Not Recommended

SAT: Saturated Solution

FUM: Fumes

Corrosion Guide

CHEMICAL ENVIRONMENT	POLYESTER		VINYL ESTER		CHEMICAL ENVIRONMENT	POLYESTER		VINYL ESTER	
	Max Wt. %	Max Oper. Temp 'F	Max Wt. %	Max Oper. Temp 'F		Max Wt. %	Max Oper. Temp 'F	Max Wt. %	Max Oper. Temp 'F
Hydrogen Bromide, Wet	100	75	100	130	Potassium Hydroxide	N/R	N/R	25	150
Hydrogen Chloride	-	120	-	200	Potassium Nitrate	SAT	170	SAT	200
Hydrogen Peroxide	5	100	30	100	Potassium Permanganate	100	80	100	210
Hydrogen Sulfide, Dry	100	170	100	210	Potassium Sulfate	SAT	170	SAT	200
Hydrogen Sulfide, Wet	100	170	100	210	Propylene Glycol	ALL	170	ALL	200
Hypochlorous Acid	20	80	20	150	Phthalic Acid	-	-	SAT	200
Isopropyl Alcohol	N/R	N/R	15	80	Sodium Acetate	SAT	160	SAT	200
Kerosene	100	140	100	180	Sodium Benzoate	SAT	170	SAT	200
Lactic Acid	SAT	170	SAT	200	Sodium Bicarbonate	SAT	160	SAT	175
Lead Acetate	SAT	170	SAT	200	Sodium Bisulfate	ALL	170	ALL	200
Lead Chloride	SAT	140	SAT	200	Sodium Bromide	ALL	170	ALL	200
Lead Nitrate	SAT	-	SAT	200	Sodium Carbonate	10	80	35	160
Linseed Oil	100	150	100	190	Sodium Chloride	SAT	170	SAT	200
Lithium Chloride	SAT	150	SAT	190	Sodium Cyanide	SAT	170	SAT	200
Magnesium Carbonate	SAT	140	SAT	170	Sodium Hydroxide	N/R	N/R	50	150
Magnesium Chloride	SAT	170	SAT	200	Sodium Hydroxide	N/R	N/R	25	80
Magnesium Hydroxide	SAT	150	SAT	190	Sodium Hypochloride	N/R	N/R	10	150
Magnesium Nitrate	SAT	140	SAT	180	Sodium Monophosphate	SAT	170	SAT	200
Magnesium Sulfate	SAT	170	SAT	190	Sodium Nitrate	SAT	170	SAT	200
Mercuric Chloride	SAT	150	SAT	190	Sodium Sulfate	SAT	170	SAT	200
Mercurous Chloride	SAT	140	SAT	180	Sodium Thiosulfate	ALL	100	ALL	120
Methyl Ethyl Ketone	N/R	N/R	N/R	N/R	Stannic Chloride	SAT	160	SAT	190
Mineral Oils	100	170	100	200	Styrene	N/R	N/R	N/R	N/R
Monochlorobenzene	N/R	N/R	N/R	N/R	Sulfated Detergent	0/50	170	0/50	200
Naphtha	100	140	100	170	Sulfur Dioxide	100	80	100	200
Nickel Chloride	SAT	170	SAT	200	Sulfur Trioxide	100	80	100	200
Nickel Nitrate	SAT	170	SAT	200	Sulfuric Acid	93	N/R	93	N/R
Nickel Sulfate	SAT	170	SAT	200	Sulfuric Acid	50	N/R	50	180
Nitric Acid	5	140	5	150	Sulfuric Acid	25	75	25	190
Nitric Acid	20	70	20	100	Sulfurous Acid	SAT	80	N/R	N/R
Oleic Acid	100	170	100	190	Tartaric Acid	SAT	170	SAT	200
Oxalic Acid	ALL	75	ALL	120	Tetrachloroethylene	N/R	N/R	FUM	75
Paper Mill Liquors	-	100	-	120	Toluene	N/R	N/R	N/R	N/R
Perchloroethylene	100	N/R	100	N/R	Trisodium Phosphate	N/R	N/R	SAT	175
Perchloric Acid	N/R	N/R	10	150	Urea	SAT	130	SAT	140
Perchloric Acid	N/R	N/R	30	80	Vinegar	100	170	100	200
Phosphoric Acid	10	160	10	200	Water, Distilled	100	170	100	190
Phosphoric Acid	100	120	100	200	Water, Tap	100	170	100	190
Potassium Aluminum Sulfate	SAT	170	SAT	200	Water, Sea	SAT	170	SAT	190
Potassium Bicarbonate	50	80	50	140	Xylene	N/R	N/R	N/R	N/R
Potassium Carbonate	10	N/R	10	120	Zinc Chloride	SAT	170	SAT	200
Potassium Chloride	SAT	170	SAT	200	Zinc Nitrate	SAT	170	SAT	200
Potassium Dichromate	SAT	170	SAT	200	Zinc Sulfate	SAT	170	SAT	200

-: No Information Available

N/R: Not Recommended

SAT: Saturated Solution

FUM: Fumes

Fiberglass - Technical Data

Load Data

Fiberglass Cable Tray and Cable Channel are offered in three (3) versions for applications as follows:

Standard Series

13F, 24F, 36F, 46F, 48F
FCC-03, FCC-04, FCC-06, FCC-08

Resin Type

Fire Retardant Polyester

Color

Gray

Meets

ASTM E-84 Class 1 - UL94 VO
Good Corrosion Resistance in most environments

High Performance

13FV, 24FV, 36FV, 46FV, 48FV
FCCV-03, FCCV-04, FCCV-06,
FCCV-08

Fire Retardant Vinyl Ester

Beige

ASTM E-84 Class 1 - UL94 VO
Improved Corrosion Resistance For more severe
environments Higher Heat Distortion Temperature



Effect of Temperature

Strength properties of reinforced plastics are reduced when continuously exposed to elevated temperatures. Working loads shall be reduced based on the chart to the right:

NEMA Standard 8-10-1986

If unusual temperature conditions exist, the manufacturer should be consulted. Authorized Engineering information 8-20-1986

Temperature in Degrees F

75
100
125
150
175
200

Approximate Percent of Strength

100
90
78
68
60
52

Typical Properties of Pultruded Components

Eaton B-Line Division Fiberglass Cable Tray systems are manufactured from glass fiber-reinforced plastic shapes that meet ASTM E-84, Smoke Density rating for polyester of 680, for vinyl ester 1025, Class 1 Flame Rating and self-extinguishing requirements of ASTM D-635. A surface veil is applied during pultrusion to insure a resin-rich surface and ultraviolet resistance.

Flame Resistance (FTMS 406-2023) ign/burn, seconds	75/75
Intermittent Flame Test (HLT-15), rating	100
Flammability Test (ASTM D635) Ignition Burning Time	none 0 sec.

Properties	Test Method	Unit/ Value	3" & 4" Cable Tray, Cable Channel		6" Cable Tray	
			Longitudinal	Transverse	Longitudinal	Transverse
Density	ASTM D1505	lbs/in ³	.058-.062	-	.072 - .076	-
Coefficient of Thermal Expansion	ASTM D696	in/in/F	5.0 x 10 ⁻⁶	-	5.0 x 10 ⁻⁶	-
Water Absorption	ASTM D570	Max %	0.5	-	0.5	-
Dielectric Strength	ASTM D149	V/mil (vpm)	200	-	200	-
Flammability Classification	UL94	VO	-	-	-	-
Flame Spread	ASTM E-84	20 Max	-	-	-	-

Expansion or Contraction for Various Temperature Differences

Temperature Differential	Cable Tray Length for 1" Expansion	Tray Length for Each Expansion Connector*
25°F (13.9°C)	667 Feet (203.3m)	417 Feet (127.1m)
50°F (27.8°C)	333 Feet (101.5m)	208 Feet (63.4m)
75°F (41.7°C)	222 Feet (67.6m)	139 Feet (42.3m)
100°F (55.6°C)	167 Feet (50.9m)	104 Feet (31.7m)
125°F (69.4°C)	133 Feet (40.5m)	83 Feet (25.3m)
150°F (83.3°C)	111 Feet (33.8m)	69 Feet (21.0m)
175°F (97.2°C)	95 Feet (28.9m)	59 Feet (18.0m)

Note for gap set and hold down/guide location, see installation instruction above.

*1" (25.4mm) slotted holes in each expansion connector allow 5/8" (15.9mm) total expansion or contraction.

Authorized Engineering Information 8-20-1986

Cable Tray Installation Guide

Installation of B-Line fiberglass cable tray should be made in accordance with the standards set by NEMA Publication VE-2, Cable Tray Installation Guide, and National Electrical Code, Article 318.

- Always observe common safety practices when assembling tray and fittings. Installations generally require some field cutting. Dust created during fabrication presents no serious health hazard, but skin irritation may be experienced by some workers.
- Operators of saws and drills should wear masks, long sleeve shirts or coveralls.
- Fabrication with fiberglass is relatively easy and comparable to working with wood. Ordinary hand tools may be used in most cases.
- Avoid excessive pressure when sawing or drilling. Too much force can rapidly dull tools and also produce excessive heat which softens the bonding resin in the fiberglass resulting in a ragged edge rather than a clean-cut edge.
- Field cutting is simple and can be accomplished with a circular power saw with an abrasive cut-off wheel (masonry type) or hack saw (24 to 32 teeth per inch).
- Drill fiberglass as you would drill hard wood. Standard twist drills are more than adequate.
- Any surface that has been drilled, cut, sanded or otherwise broken, **must be sealed** with a compatible resin. (see page M-28)
- Carbide tipped saw blades and drill bits are recommended when cutting large quantities.
- Support the fiberglass material firmly during cutting operations to keep material from shifting which may cause chipping at the cut edge.
- Each tray section length should be equal to or greater than the support span.
- When possible, the splice should be located at quarter span.
- Fittings should be supported as per NEMA FG-1.

Recommended Fiberglass Trapeze Hanging Systems

Notes:

- 1) A snug three to four ft.-lbs. torque is sufficient for all thread rod nuts.
- 2) When supporting cable tray, the spacing between each trapeze should not exceed the distance between splice plates.
- 3) When hanging from beam, B-Line series BFV751 series clamps provide extra thread engagement necessary for load ratings. All thread rod must be fully engaged in the clamp.
- 4) Design load safety factor is 3:1

BF22A Strut: 2" max between material being supported and rod

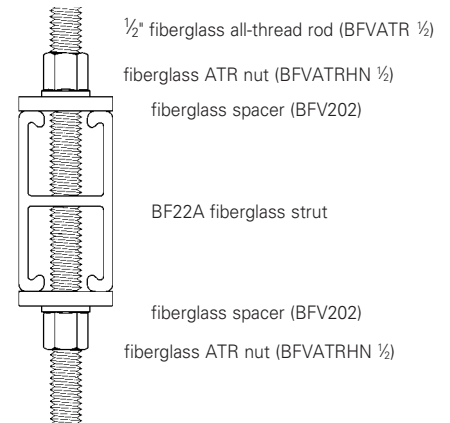
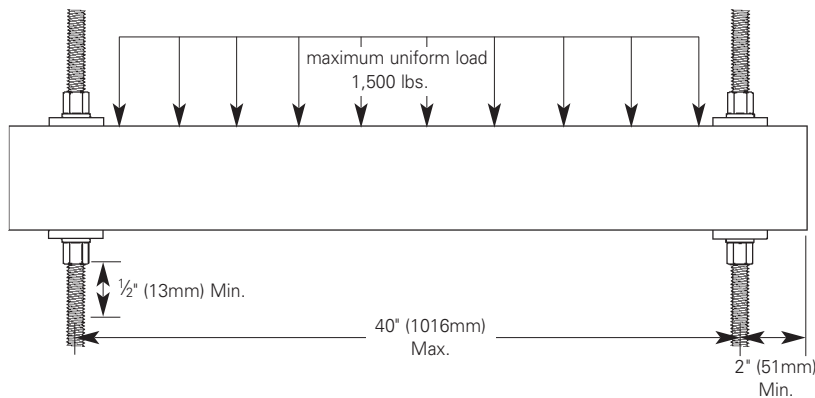

BF22 Strut: 2" max between material being supported and rod

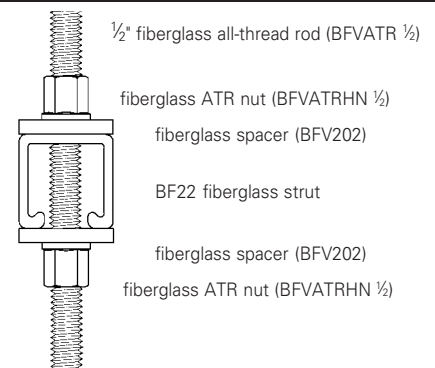
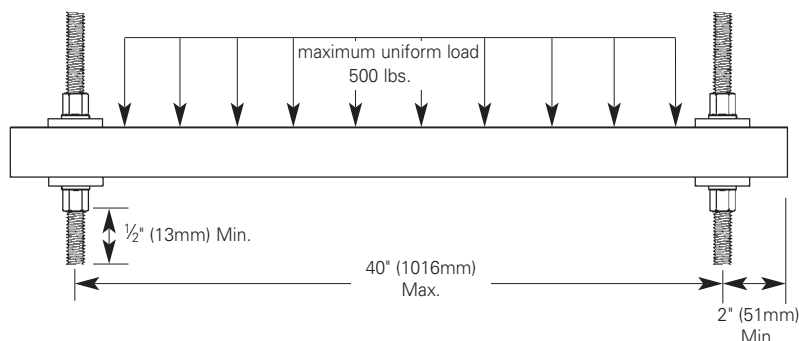

For vinyl ester resin, 'V' must be added appropriately to part number. Example: BFV22A.

SECTION 161xx NON-METALLIC CABLE TRAY POLYESTER, VINYL ESTER

PART 1 - GENERAL

1.01 SECTION INCLUDES

- A. The work covered under this section consists of the furnishing of all necessary labor, supervision, materials, equipment, tests and services to install complete cable tray systems as shown on the drawings.
- B. Cable tray systems are defined to include, but are not limited to straight sections of [ladder type] [vented bottom type] [solid bottom type] cable trays, bends, tees, elbows, drop-outs, supports and accessories.

1.02 REFERENCES

- A. ANSI/NFPA 70 – National Electrical Code
- B. NEMA FG 1-2002 – Non-Metallic Cable Tray Systems
- C. NEMA VE 2-2002 – Cable Tray Installation Guidelines

1.03 DRAWINGS

- A. The drawings, which constitute a part of these specifications, indicate the general route of the cable tray systems. Data presented on these drawings are as accurate as preliminary surveys and planning can determine until final equipment selection is made. Accuracy is not guaranteed and field verification, of all dimensions, routing, etc., is directed.
- B. Specifications and drawings are for assistance and guidance, but exact routing, locations, distances and levels will be governed by actual field conditions. Contractor is directed to make field surveys as part of his work prior to submitting system layout drawings.

1.04 SUBMITTALS

- A. Submittal Drawings: Submit drawings of cable tray and accessories including clamps, brackets, hanger rods, splice plate connectors, expansion joint assemblies, and fittings, showing accurately scaled components.
- B. Product Data: Submit manufacturer's data on cable tray including, but not limited to, types, materials, finishes, rung spacings, inside depths and fitting radii. For side rails and rungs, submit cross sectional properties including Section Modulus (Sx) and Moment of Inertia (Ix).

1.05 QUALITY ASSURANCE

- A. Manufacturers: Firms regularly engaged in manufacture of cable trays and fittings of types and capacities required, whose products have been in satisfactory use in similar service for not less than 5 years.
- B. NEMA Compliance: Comply with NEMA Standards Publication Number FG-1, "Non-Metallic Cable Tray Systems".
- C. NEC Compliance: Comply with NEC, as applicable to construction and installation of cable tray and cable channel systems (Article 318, NEC).

1.06 DELIVERY, STORAGE AND HANDLING

- A. Deliver cable tray systems and components carefully to avoid breakage, denting and scoring finishes. Do not install damaged equipment.
- B. Store cable trays and accessories in original cartons and in clean dry space; protect from weather and construction traffic. Wet materials should be unpacked and dried before storage.

continued on page M-8

PART 2 - PRODUCTS

2.01 ACCEPTABLE MANUFACTURERS

- A. Subject to compliance with these specifications, Eaton's B-Line series cable tray systems shall be as manufactured by Eaton.

2.02 CABLE TRAY SECTIONS AND COMPONENTS

- A. General: Except as otherwise indicated, provide non-metallic cable trays, of types, classes, and sizes indicated; with splice plates, bolts, nuts and washers for connecting units. Construct units with rounded edges and smooth surfaces; in compliance with applicable standards; and with the following additional construction features. Cable tray shall be installed according to the latest revision of NEMA VE 2.
- B. Material and Finish: Straight section structural elements; side rails, rungs and splice plates shall be pultruded from glass fiber reinforced polyester resin, vinyl ester resin or dis-stat.
- C. Pultruded shapes shall be constructed with a surface veil to insure a resin-rich surface and ultraviolet resistance.
- D. Pultruded shapes shall meet ASTM E-84, Class 1 flame rating and self-extinguishing requirements of ASTM D-635.

2.03 TYPE OF TRAY SYSTEM

- A. Ladder Cable Trays shall consist of two longitudinal members (side rails) with transverse members (rungs) mechanically fastened and adhesively bonded to the side rails. Rungs shall be spaced [6] [9] [12] inches apart. Rung spacing in radiused fittings shall be industry standard 9" and measured at the center of the tray's width. Each rung must be capable of supporting a 200 lb. concentrated load at the center of the cable tray with a safety factor of 1.5 (See following rung loading table).
- B. Ventilated Bottom Cable Trays shall consist of two longitudinal members (side rails) with rungs spaced 4" apart.
- C. Solid Bottom Cable Trays shall consist of two longitudinal members (side rails) with a solid sheet over rungs spaced on 12" centers.
- D. Cable tray loading depth shall be [2] [3] [5] inches per NEMA FG 1.
- E. Straight sections shall be supplied in standard [10 foot (3m)] [20 foot (6m)] lengths.
- F. Cable tray inside widths shall be [6] [9] [12] [18] [24] [30] [36] inches or as shown on drawings. Outside width shall not exceed inside by more than a total of 2".
- G. Straight and expansion splice plates will be of "L" shaped lay-in design with an eight-bolt pattern in 5" fill systems and four-bolt pattern in 3" and 2" fill systems. Splice plates shall be furnished with straight sections and fittings.
- H. All fittings must have a minimum radius of [12] [24] [36].
 - I. Fittings shall be of mitered construction.
 - J. Dimension tolerances will be per NEMA FG 1.

2.04 LOADING CAPACITIES

- A. Cable trays shall meet NEMA class designation: [8C] [12C] [20B] [20C].

Or

- A. Cable tray shall be capable of carrying a uniformly distributed load of _____ lbs./ft on a _____ foot support span with a safety factor of 1.5 when supported as a simple span and tested per NEMA VE 1 Section 5.2.

continued on page M-9

PART 3 - EXECUTION

3.01 INSTALLATION

- A.** Install cable trays as indicated: Installation shall be in accordance with equipment manufacturer's instructions, and with recognized industry practices to ensure that cable tray equipment comply with requirements of NEC and applicable portions of NFPA 70B. Reference NEMA VE 2 for general cable tray installation guidelines.
- B.** Coordinate cable tray with other electrical work as necessary to properly integrate installation of cable tray work with other work.
- C.** Provide sufficient space encompassing cable trays to permit access for installing and maintaining cables.
- D.** Cable tray fitting supports shall be located such that they meet the strength requirements of straight sections. Install fitting supports per NEMA VE 2 guidelines, or in accordance with manufacturer's instructions.

3.02 TESTING

- A.** Upon request manufacturer shall provide test reports witnessed by an independent testing laboratory of the "worst case" loading conditions outlined in this specification and performed in accordance with the latest revision of NEMA FG 1.

Fiberglass - Cable Tray Numbering System

To order a Fiberglass straight section of cable tray, select the appropriate size and material from the charts below and place those symbols in the sequence shown to form the complete catalog number.

Procedure:

1. Select the correct B-Line series Fiberglass tray using the Load Data for straight sections shown on page M-11 for 3", page M-12 for 4", page M-13 & M-14 for 6", and page M-15 for 8" fittings.
2. Select the resin required. Polyester or Vinyl Ester. Refer to Corrosion Guide on pages M-3 and M-4, for the effect of environmental conditions on the desired material and the effective temperature range on page M-5.
3. The tray prefix is completed by inserting the rung spacing.
4. Select the desired width in inches.
5. Finally select the straight section length in inches.
Fiberglass 120 [10'] (3m) or 240 [20'] (6m)

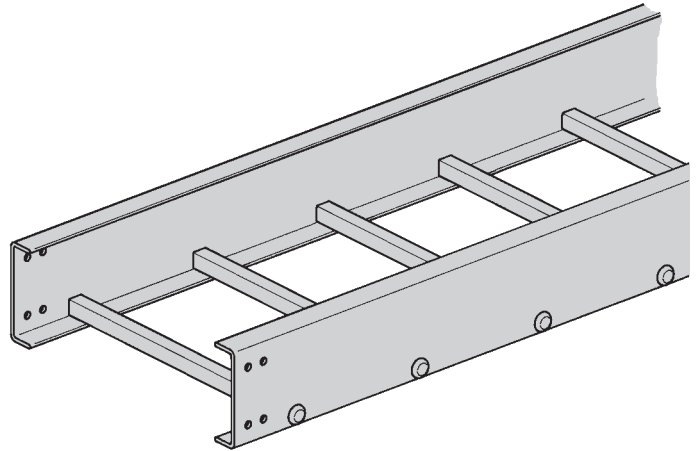

Straight Section Part Numbering

Example: **24 F 09 - 24 - 120**

Prefix

Series	Material	Rung Spacing	Width	Length
13	F - Fiberglass (Gray)	06 = 6" (152)	06 = 6" (152)	120 = 120" (3m)
24	Polyester Resin	09 = 9" (228)	09 = 9" (228)	240 = 240" (6m)
36	FV - Fiberglass (Beige)	12 = 12" (305)	12 = 12" (305)	
46	Vinyl Ester Resin	† SB = Solid Bottom	18 = 18" (457)	
48		*See page APP-1 for Marine Rung option.	24 = 24" (609)	
			30 = 30" (762)	
			36 = 36" (914)	

† Solid bottom sheets ship separately with connecting hardware and assembled on site.

Note: One pair of splice plates with SS6 hardware included.

Fitting Section Part Selector

Example: **4 F SB - 24 - 90 HB 24**

Prefix

Height	Material	Bottom	Width	Angle	Type	Radius
3" (76)	F - Fiberglass (Gray)	Blank =	6" (152)	45°	HB - Horizontal Bend	12" (305)
4" (101)	Polyester Resin	Ladder Type	9" (228)	90°	HT - Horizontal Tee	24" (609)
6" (152)	FV - Fiberglass (Beige)	SB =	12" (305)		HX - Horizontal Cross	36" (914)
8" (203)	Vinyl Ester Resin	Solid Bottom	18" (457)		VI - Vertical Inside Bend	
			24" (609)		VO - Vertical Outside Bend	
			30" (762)		VT - Vertical Tee	
			36" (914)		VTU - Vertical Tee, Up	
					RR - Right Reducer	
					LR - Left Reducer	
					SR - Straight Reducer	

Notes: Standard rung spacing on fittings is 9" (225).
Splice plates with SS6 hardware included.

Fiberglass

Fiberglass - 3" Straight Section

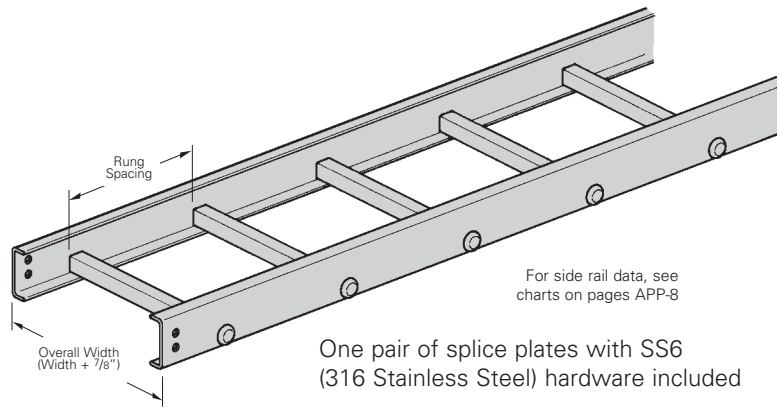
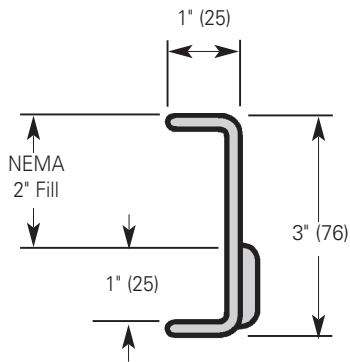

Series 13 Fiberglass Straight Section Part Numbering

Prefix
Example: **13 F 09 - 24 - 120**

<p>Series 13</p>	<p>Material ● F = Polyester ● FV = Vinyl Ester</p>	<p>Type Ladder - ● 06 = 6" rung spacing ● 09 = 9" rung spacing ● 12 = 12" rung spacing ● SB = Solid bottom †</p>	<p>Width ● 06 = 6" ● 09 = 9" ● 12 = 12" ● 18 = 18" ● 24 = 24"</p>	<p>Length ● ① 120 = 10 ft. ● ② 240 = 20 ft.</p> <p>① Primary Length. ② Secondary Length.</p> <p>See page C-23 for explanation of lengths.</p>
-----------------------------	---	---	---	--

† Solid bottom sheets ship separately with connecting hardware and assembled on site.

See page M-34 for additional rung options.

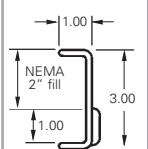

B-Line Series	Side Rail Dimensions	NEMA Classifications	Span ft	Load lbs/ft	Deflection Multiplier	Span meters	Load kg/m	Deflection Multiplier
13F 13FV		NEMA: 8C	6	257	0.005	1.8	382	0.086
			8	145	0.016	2.4	216	0.267
			10	93	0.040	3.0	138	0.681
			12	64	0.083	3.7	95	1.411
			14	47	0.153	4.3	70	2.614

Values are based on simple beam tests per NEMA FG-1 on 24" wide cable tray rungs spaced on 12" centers. Published load safety factor is 1.5. To convert 1.5 safety factor to 2.0, multiply published load by 0.75. To obtain mid-span deflection, multiply a load by the deflection multiplier. Cable tray must be supported on spans shorter than or equal to the length of the cable being installed.

When trays are used in continuous spans, the deflection of the tray is reduced by as much as 50%.

● Green = Fastest shipped items ● Black = Normal lead-time items ● Red = Normally long lead-time items

Dimensions shown in parentheses are in millimeters, unless otherwise specified.

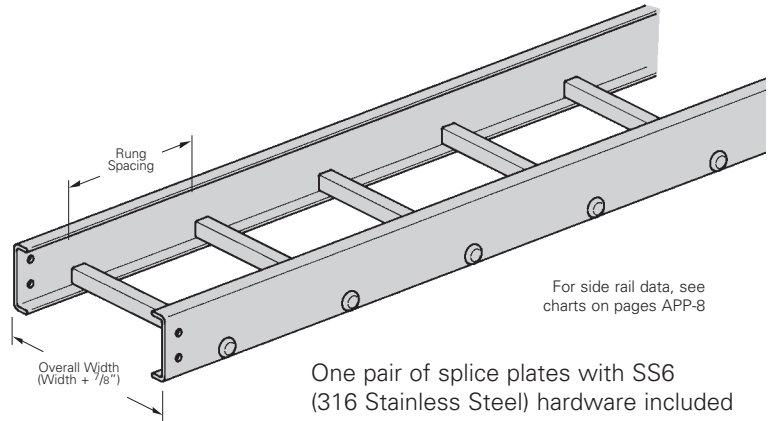
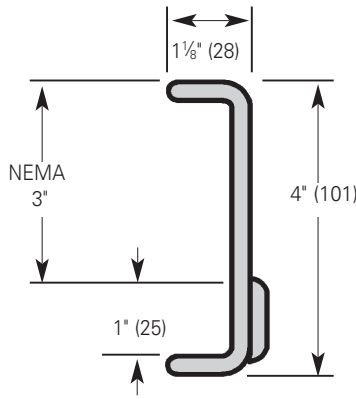

Series 24 Fiberglass Straight Section Part Numbering

Example: ^{Prefix} **24 F 09 - 24 - 120**

Series

24

Material

- **F** = Polyester
- **FV** = Vinyl Ester



Type

- Ladder -**
- **06** = 6" rung spacing
 - **09** = 9" rung spacing
 - **12** = 12" rung spacing
 - **SB** = Solid bottom †

Width

- **06** = 6"
- **09** = 9"
- **12** = 12"
- **18** = 18"
- **24** = 24"
- **30** = 30"
- **36** = 36"

Length

- ① **120** = 10 ft.
- ② **240** = 20 ft.

① Primary Length.
 ② Secondary Length.
 See page C-23 for explanation of lengths.

† Solid bottom sheets ship separately with connecting hardware and assembled on site.

See page M-34 for additional rung options.

B-Line Series	Side Rail Dimensions	NEMA & CSA Classifications	Span ft	Load lbs/ft	Deflection Multiplier	Span meters	Load kg/m	Deflection Multiplier
24F 24FV		NEMA: 12C CSA: E-3m	6	627	0.001	1.8	933	0.023
			8	353	0.004	2.4	525	0.074
			10	226	0.011	3.0	336	0.182
			12	157	0.022	3.7	233	0.378

Values are based on simple beam tests per NEMA FG-1 on 36" wide cable tray rungs spaced on 12" centers. Published load safety factor is 1.5. To convert 1.5 safety factor to 2.0, multiply published load by 0.75. To obtain mid-span deflection, multiply a load by the deflection multiplier. Cable tray must be supported on spans shorter than or equal to the length of the cable being installed.

When trays are used in continuous spans, the deflection of the tray is reduced by as much as 50%.

● Green = Fastest shipped items ● Black = Normal lead-time items ● Red = Normally long lead-time items

Dimensions shown in parentheses are in millimeters, unless otherwise specified.

Fiberglass - 6" Straight Section

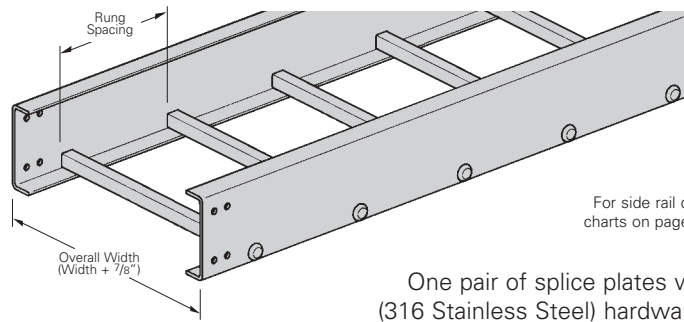
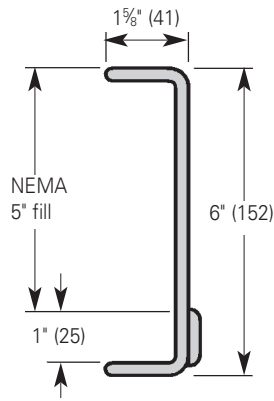

For side rail data, see charts on pages APP-8

One pair of splice plates with SS6 (316 Stainless Steel) hardware included

Series 36 Fiberglass Straight Section Part Numbering

Example: ^{Prefix} **36 F 09 - 24 - 120**

Series

36

Material

- **F** = Polyester
- **FV** = Vinyl Ester

Type

Ladder -

- **06** = 6" rung spacing
- **09** = 9" rung spacing
- **12** = 12" rung spacing
- **SB** = Solid bottom †

Width

- **06** = 6"
- **09** = 9"
- **12** = 12"
- **18** = 18"
- **24** = 24"
- **30** = 30"
- **36** = 36"

Length

- ① **120** = 10 ft.
- ② **240** = 20 ft.

① Primary Length.

② Secondary Length.

See page C-23 for explanation of lengths.



† Solid bottom sheets ship separately with connecting hardware and assembled on site.

See page M-34 for additional rung options.

B-Line Series	Side Rail Dimensions	NEMA & CSA Classifications	Span ft	Load lbs/ft	Deflection Multiplier	Span meters	Load kg/m	Deflection Multiplier
36F 36FV		NEMA: 20B CSA: E-6m	12	241	0.005	3.7	359	0.081
			14	177	0.009	4.3	264	0.151
			16	136	0.015	4.9	202	0.257
			18	107	0.024	5.5	159	0.411
			20	87	0.037	6.1	129	0.627

Values are based on simple beam tests per NEMA FG-1 on 36" wide cable tray rungs spaced on 12" centers. Published load safety factor is 1.5. To convert 1.5 safety factor to 2.0, multiply published load by 0.75. To obtain mid-span deflection, multiply a load by the deflection multiplier. Cable tray must be supported on spans shorter than or equal to the length of the cable being installed.

When trays are used in continuous spans, the deflection of the tray is reduced by as much as 50%.

● Green = Fastest shipped items ● Black = Normal lead-time items ● Red = Normally long lead-time items

Dimensions shown in parentheses are in millimeters, unless otherwise specified.

Fiberglass - 6" Straight Section

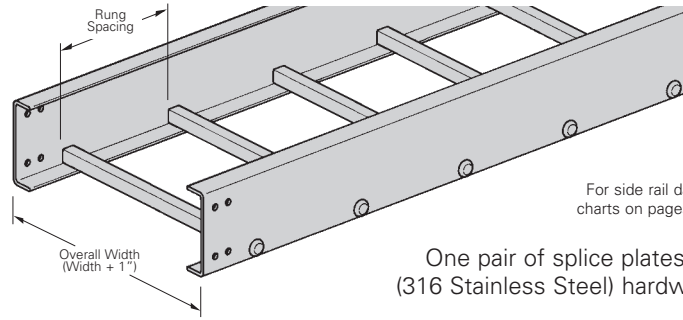
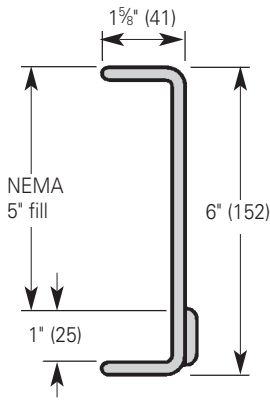

For side rail data, see charts on pages APP-8

One pair of splice plates with SS6 (316 Stainless Steel) hardware included

Series 46 Fiberglass Straight Section Part Numbering

Example: ^{Prefix} **46 F 09 - 24 - 120**

Series

46

Material

- **F** = Polyester
- **FV** = Vinyl Ester

Type

- Ladder -**
- **06** = 6" rung spacing
 - **09** = 9" rung spacing
 - **12** = 12" rung spacing
 - **SB** = Solid bottom †

Width

- **06** = 6"
- **09** = 9"
- **12** = 12"
- **18** = 18"
- **24** = 24"
- **30** = 30"
- **36** = 36"

Length

- ① **120** = 10 ft.
- ② **240** = 20 ft.

① Primary Length.
② Secondary Length.

See page C-23 for explanation of lengths.



† Solid bottom sheets ship separately with connecting hardware and assembled on site.

See page M-34 for additional rung options.

B-Line Series	Side Rail Dimensions	NEMA & CSA Classifications	Span ft	Load lbs/ft	Deflection Multiplier	Span meters	Load kg/m	Deflection Multiplier
46F 46FV		NEMA: 20C+ CSA: E-6m	12	393	0.005	3.7	584	0.079
			14	288	0.009	4.3	429	0.145
			16	221	0.015	4.9	329	0.246
			18	174	0.023	5.5	260	0.396
			20	141	0.035	6.1	210	0.605

Values are based on simple beam tests per NEMA FG-1 on 36" wide cable tray rungs spaced on 12" centers. Published load safety factor is 1.5. To convert 1.5 safety factor to 2.0, multiply published load by 0.75. To obtain mid-span deflection, multiply a load by the deflection multiplier. Cable tray must be supported on spans shorter than or equal to the length of the cable being installed.

When trays are used in continuous spans, the deflection of the tray is reduced by as much as 50%.

● Green = Fastest shipped items ● Black = Normal lead-time items ● Red = Normally long lead-time items

Dimensions shown in parentheses are in millimeters, unless otherwise specified.

Fiberglass - 8" Straight Section

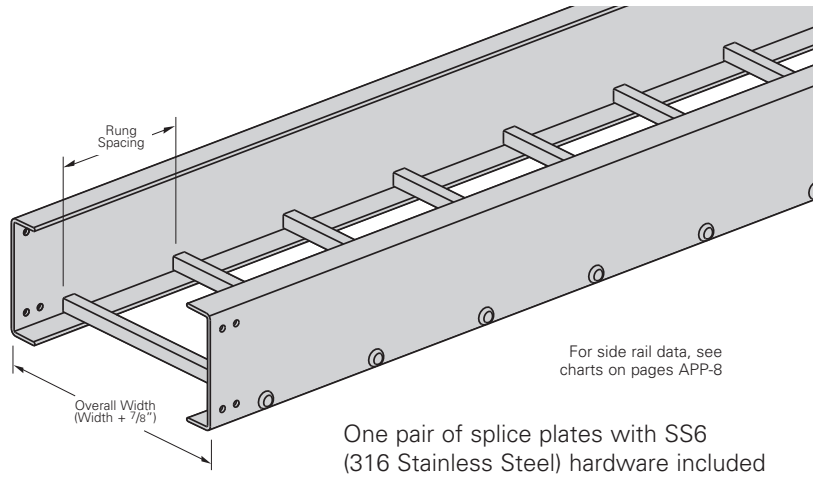
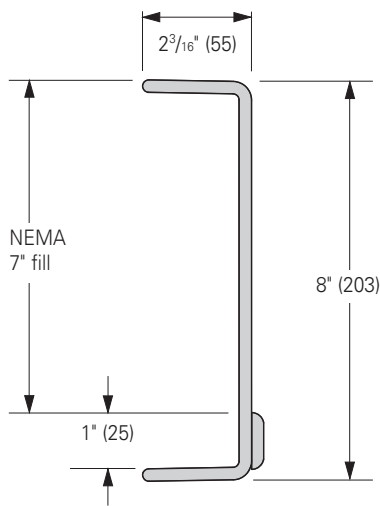

Series 48 Fiberglass Straight Section Part Numbering

Prefix
Example: **48 F 09 - 24 - 120**

Series

48

Material

- **F** = Polyester
- **FV** = Vinyl Ester



Type

- Ladder -**
- **06** = 6" rung spacing
 - **09** = 9" rung spacing
 - **12** = 12" rung spacing
 - **SB** = Solid bottom †

Width

- **06** = 6"
- **09** = 9"
- **12** = 12"
- **18** = 18"
- **24** = 24"
- **30** = 30"
- **36** = 36"

Length

- ① **120** = 10 ft.
- ② **240** = 20 ft.

- ① Primary Length.
- ② Secondary Length.

See page C-23 for explanation of lengths.

† Solid bottom sheets ship separately with connecting hardware and assembled on site.

See page M-34 for additional rung options.

B-Line Series	Side Rail Dimensions	NEMA Classifications	Span ft	Load lbs/ft	Deflection Multiplier	Span meters	Load kg/m	Deflection Multiplier
48F 48FV		NEMA: 20C+	12	348	0.003	3.7	518	0.052
			14	256	0.006	4.3	381	0.097
			16	196	0.010	4.9	291	0.165
			18	155	0.015	5.5	231	0.210
			20	125	0.024	6.1	187	0.401

Values are based on simple beam tests per NEMA FG-1 on 36" wide cable tray rungs spaced on 12" centers. Published load safety factor is 1.5. To convert 1.5 safety factor to 2.0, multiply published load by 0.75. To obtain mid-span deflection, multiply a load by the deflection multiplier. Cable tray must be supported on spans shorter than or equal to the length of the cable being installed.

When trays are used in continuous spans, the deflection of the tray is reduced by as much as 50%.

- Green = Fastest shipped items
- Black = Normal lead-time items
- Red = Normally long lead-time items

Dimensions shown in parentheses are in millimeters, unless otherwise specified.

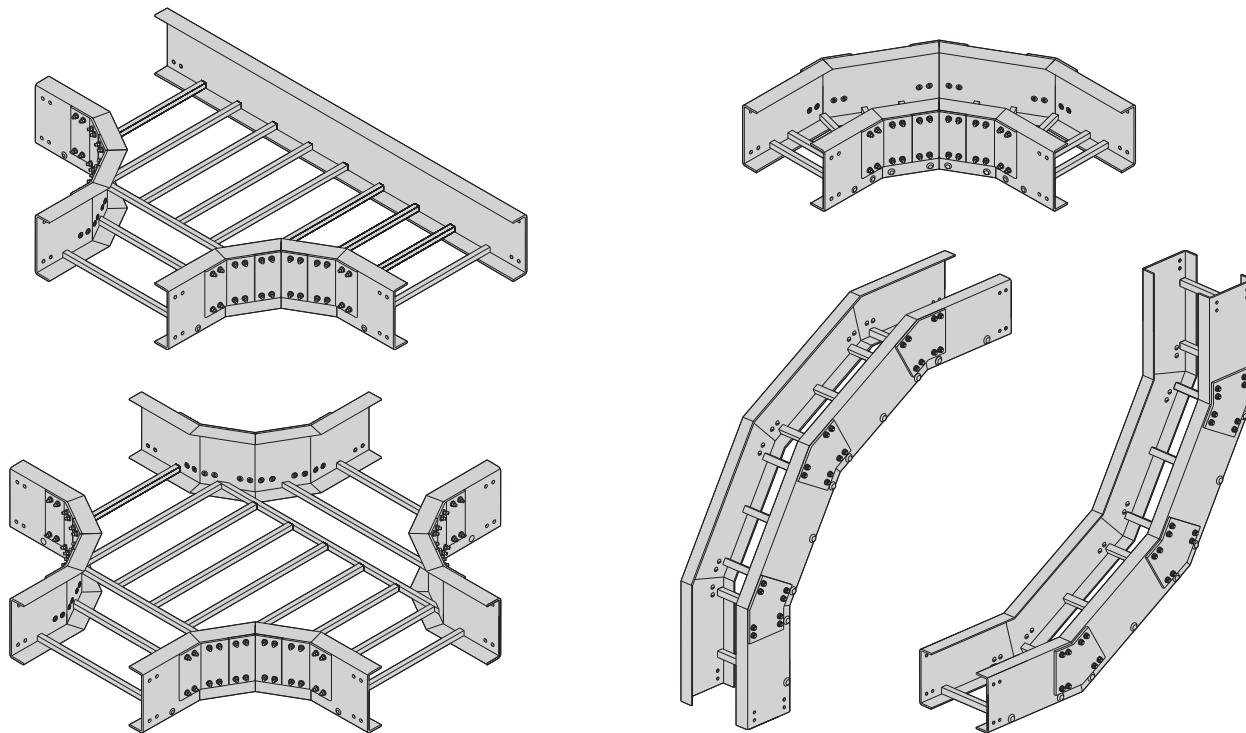

Fiberglass Fittings Part Numbering

Example: ^{Prefix} **4 F SB - 12 - 90 HB 12** (9" rung spacing is standard)

Height	Material	Bottom	Width	Angle	Type	Radius
<ul style="list-style-type: none"> ● 3 = 3" ** ● 4 = 4" ● 6 = 6" ● 8 = 8" 	<ul style="list-style-type: none"> ● F = Polyester ● FV = Vinyl Ester 	<ul style="list-style-type: none"> ● Blank = Ladder Type ● SB = Solid Bottom† 	<ul style="list-style-type: none"> ● 06 = 6" (152) ● 09 = 9" (228) ● 12 = 12" (305) ● 18 = 18" (457) ● 24 = 24" (609) ● 30 = 30" (762) ● 36 = 36" (914) 	<ul style="list-style-type: none"> ● 45 = 45° ● 90 = 90° 	<ul style="list-style-type: none"> ● HB = Horizontal Bend ● HT = Horizontal Tee ● HX = Horizontal Cross ● VI = Vertical Inside Bend ● VO = Vertical Outside Bend ● LR = Left Reducer ● RR = Right Reducer ● SR = Straight Reducer 	<ul style="list-style-type: none"> ● 12 = 12" (305) ● 24 = 24" (609) ● 36 = 36" (914)

** 3" deep fittings are available in 6" thru 24" widths and 12" radius only.

† Solid bottom sheets ship separately with connecting hardware and assembled on site.

● Green = Fastest shipped items ● Black = Normal lead-time items ● Red = Normally long lead-time items

Dimensions shown in parentheses are in millimeters, unless otherwise specified.

Horizontal Bend 90° (HB)

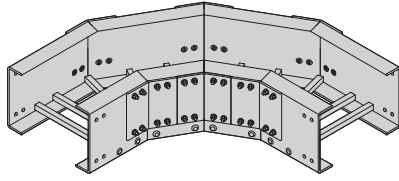

One pair of splice plates with SS6 hardware required to connect to system.

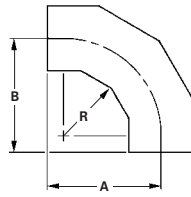

90° Mitered

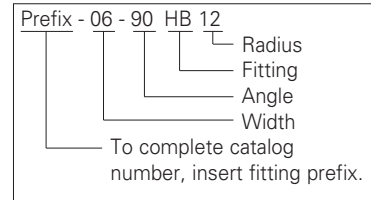

(Prefix) See page M-16 for catalog number prefix.
Dimensions for reference only, when critical contact factory.

- R - Bend Radius in. (mm)	Tray Width in. (mm)	90° Horizontal Bend - Mitered Dimensions				
		Catalog No.	A		B	
			in.	(mm)	in.	(mm)
12 (305)	6 (152)	(Prefix)-06-90HB12	28 ^{11/16}	(728)	28 ^{11/16}	(728)
	9 (228)	(Prefix)-09-90HB12	30 ^{3/16}	(767)	30 ^{3/16}	(767)
	12 (305)	(Prefix)-12-90HB12	31 ^{11/16}	(805)	31 ^{11/16}	(805)
	18 (457)	(Prefix)-18-90HB12	34 ^{11/16}	(881)	34 ^{11/16}	(881)
	24 (609)	(Prefix)-24-90HB12	37 ^{11/16}	(957)	37 ^{11/16}	(957)
	30 (762)	(Prefix)-30-90HB12	40 ^{11/16}	(1033)	40 ^{11/16}	(1033)
	36 (914)	(Prefix)-36-90HB12	43 ^{11/16}	(1109)	43 ^{11/16}	(1109)
24 (609)	6 (152)	(Prefix)-06-90HB24	41	(1041)	41	(1041)
	9 (228)	(Prefix)-09-90HB24	42 ^{1/2}	(1079)	42 ^{1/2}	(1079)
	12 (305)	(Prefix)-12-90HB24	44	(1117)	44	(1117)
	18 (457)	(Prefix)-18-90HB24	47	(1193)	47	(1193)
	24 (609)	(Prefix)-24-90HB24	50	(1269)	50	(1269)
	30 (762)	(Prefix)-30-90HB24	53	(1346)	53	(1346)
	36 (914)	(Prefix)-36-90HB24	56	(1422)	56	(1422)
36 (914)	6 (152)	(Prefix)-06-90HB36	53 ^{1/4}	(1353)	53 ^{1/4}	(1353)
	9 (228)	(Prefix)-09-90HB36	54 ^{3/4}	(1391)	54 ^{3/4}	(1391)
	12 (305)	(Prefix)-12-90HB36	56 ^{1/4}	(1429)	56 ^{1/4}	(1429)
	18 (457)	(Prefix)-18-90HB36	59 ^{1/4}	(1505)	59 ^{1/4}	(1505)
	24 (609)	(Prefix)-24-90HB36	62 ^{1/4}	(1582)	62 ^{1/4}	(1582)
	30 (762)	(Prefix)-30-90HB36	65 ^{1/4}	(1658)	65 ^{1/4}	(1658)
	36 (914)	(Prefix)-36-90HB36	68 ^{1/4}	(1734)	68 ^{1/4}	(1734)

For 3" Fittings

(Tray Widths - 6" thru 24" • Radius 12" only)
Polyester, Vinyl Ester
All are mitered

For 6" Fittings

(Tray Widths - 6" thru 36" • Radius 12", 24" & 36")
Polyester, Vinyl Ester
All radius are mitered

For 4" Fittings

(Tray Widths - 6" thru 36" • Radius 12", 24" & 36")
Polyester, Vinyl Ester
All radius are mitered

For 8" Fittings

(Tray Widths - 6" thru 36" • Radius 12", 24" & 36")
Polyester, Vinyl Ester
All radius are mitered

● Green = Fastest shipped items ● Black = Normal lead-time items ● Red = Normally long lead-time items

Dimensions shown in parentheses are in millimeters, unless otherwise specified.

Horizontal Bend 45° (HB)

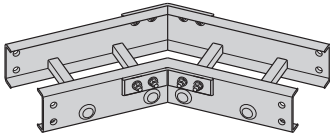

One pair of splice plates with SS6 hardware required to connect to system.

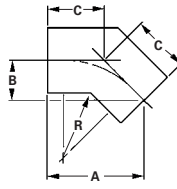

45° Mitered

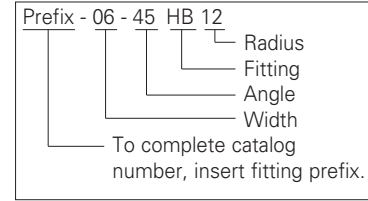

(Prefix) See page M-16 for catalog number prefix.
Dimensions for reference only, when critical contact factory.

- R - Bend Radius in. (mm)	Tray Width in. (mm)	45° Horizontal Bend - Mitered Dimensions			
		Catalog No.	A in. (mm)	B in. (mm)	C in. (mm)
12 (305)	6 (152)	(Prefix)-06-45HB12	24 ²¹ / ₃₂ (626)	10 ⁷ / ₃₂ (259)	14 ⁷ / ₁₆ (367)
	9 (228)	(Prefix)-09-45HB12	25 ²³ / ₃₂ (653)	10 ²¹ / ₃₂ (271)	15 ¹ / ₁₆ (383)
	12 (305)	(Prefix)-12-45HB12	26 ²⁵ / ₃₂ (680)	11 ³ / ₃₂ (282)	15 ¹¹ / ₁₈ (398)
	18 (457)	(Prefix)-18-45HB12	28 ²⁹ / ₃₂ (734)	11 ³¹ / ₃₂ (304)	16 ¹⁵ / ₁₆ (430)
	24 (609)	(Prefix)-24-45HB12	31 ¹ / ₃₂ (788)	12 ²⁷ / ₃₂ (326)	18 ⁵ / ₃₂ (462)
	30 (762)	(Prefix)-30-45HB12	33 ⁵ / ₃₂ (842)	13 ³ / ₄ (349)	19 ¹³ / ₃₂ (493)
	36 (914)	(Prefix)-36-45HB12	35 ¹ / ₄ (896)	14 ⁵ / ₈ (371)	20 ²¹ / ₃₂ (525)
24 (609)	6 (152)	(Prefix)-06-45HB12	24 ²¹ / ₃₂ (626)	10 ⁷ / ₃₂ (259)	14 ⁷ / ₁₆ (367)
	9 (228)	(Prefix)-09-45HB12	25 ²³ / ₃₂ (653)	10 ²¹ / ₃₂ (271)	15 ¹ / ₁₆ (383)
	12 (305)	(Prefix)-12-45HB12	26 ²⁵ / ₃₂ (680)	11 ³ / ₃₂ (282)	15 ¹¹ / ₁₈ (398)
	18 (457)	(Prefix)-18-45HB12	28 ²⁹ / ₃₂ (734)	11 ³¹ / ₃₂ (304)	16 ¹⁵ / ₁₆ (430)
	24 (609)	(Prefix)-24-45HB12	31 ¹ / ₃₂ (788)	12 ²⁷ / ₃₂ (326)	18 ⁵ / ₃₂ (462)
	30 (762)	(Prefix)-30-45HB12	33 ⁵ / ₃₂ (842)	13 ³ / ₄ (349)	19 ¹³ / ₃₂ (493)
	36 (914)	(Prefix)-36-45HB12	35 ¹ / ₄ (896)	14 ⁵ / ₈ (371)	20 ²¹ / ₃₂ (525)
36 (914)	6 (152)	(Prefix)-06-45HB12	24 ²¹ / ₃₂ (626)	10 ⁷ / ₃₂ (259)	14 ⁷ / ₁₆ (367)
	9 (228)	(Prefix)-09-45HB12	25 ²³ / ₃₂ (653)	10 ²¹ / ₃₂ (271)	15 ¹ / ₁₆ (383)
	12 (305)	(Prefix)-12-45HB12	26 ²⁵ / ₃₂ (680)	11 ³ / ₃₂ (282)	15 ¹¹ / ₁₈ (398)
	18 (457)	(Prefix)-18-45HB12	28 ²⁹ / ₃₂ (734)	11 ³¹ / ₃₂ (304)	16 ¹⁵ / ₁₆ (430)
	24 (609)	(Prefix)-24-45HB12	31 ¹ / ₃₂ (788)	12 ²⁷ / ₃₂ (326)	18 ⁵ / ₃₂ (462)
	30 (762)	(Prefix)-30-45HB12	33 ⁵ / ₃₂ (842)	13 ³ / ₄ (349)	19 ¹³ / ₃₂ (493)
	36 (914)	(Prefix)-36-45HB12	35 ¹ / ₄ (896)	14 ⁵ / ₈ (371)	20 ²¹ / ₃₂ (525)

For 3" Fittings

(Tray Widths - 6" thru 24" • Radius 12" only)
Polyester, Vinyl Ester
All are mitered

For 6" Fittings

(Tray Widths - 6" thru 36"
Radius 12", 24" & 36")
Polyester, Vinyl Ester
All radius are mitered

For 4" Fittings

(Tray Widths - 6" thru 36"
Radius 12", 24" & 36")
Polyester, Vinyl Ester
All radius are mitered

For 8" Fittings

(Tray Widths - 6" thru 36"
Radius 12", 24" & 36")
Polyester, Vinyl Ester
All radius are mitered

Dimensions shown in parentheses are in millimeters, unless otherwise specified.

Horizontal Tee (HT)

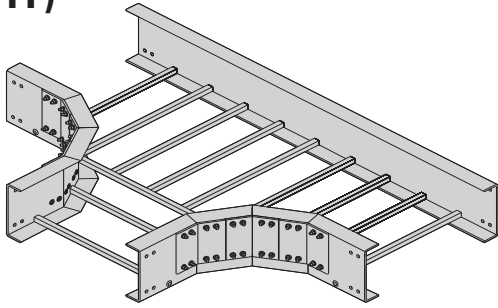

Two pair of splice plates with SS6 hardware required to connect to system.

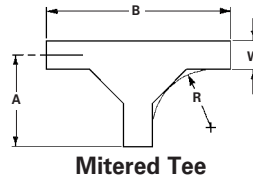

Mitered Tee

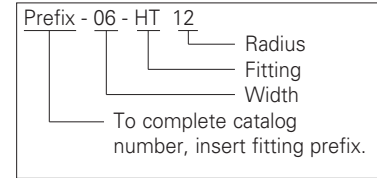

(Prefix) See page M-16 for catalog number prefix.
Dimensions for reference only, when critical contact factory.

- R - Bend Radius in. (mm)	Tray Width in. (mm)	Horizontal Tee - Mitered Dimensions		
		Catalog No.	A in. (mm)	B in. (mm)
12 (305)	6 (152)	(Prefix)-06-HT12	28 ⁷ / ₃₂ (716)	56 ¹³ / ₃₂ (1433)
	9 (228)	(Prefix)-09-HT12	29 ¹¹ / ₁₆ (754)	59 ¹³ / ₃₂ (1509)
	12 (305)	(Prefix)-12-HT12	31 ⁷ / ₃₂ (792)	62 ¹³ / ₃₂ (1585)
	18 (457)	(Prefix)-18-HT12	34 ⁷ / ₃₂ (869)	68 ¹³ / ₃₂ (1737)
	24 (609)	(Prefix)-24-HT12	37 ⁷ / ₃₂ (945)	74 ¹³ / ₃₂ (1890)
	30 (762)	(Prefix)-30-HT12	40 ⁷ / ₃₂ (1021)	80 ¹³ / ₃₂ (2042)
	36 (914)	(Prefix)-36-HT12	43 ⁷ / ₃₂ (1097)	86 ¹³ / ₃₂ (2195)
24 (609)	6 (152)	(Prefix)-06-HT24	40 ⁷ / ₃₂ (1021)	80 ¹³ / ₃₂ (2042)
	9 (228)	(Prefix)-09-HT24	41 ¹¹ / ₁₆ (1059)	83 ¹³ / ₃₂ (2118)
	12 (305)	(Prefix)-12-HT24	43 ⁷ / ₃₂ (1097)	86 ¹³ / ₃₂ (2195)
	18 (457)	(Prefix)-18-HT24	46 ⁷ / ₃₂ (1173)	92 ¹³ / ₃₂ (2347)
	24 (609)	(Prefix)-24-HT24	49 ⁷ / ₃₂ (1250)	98 ¹³ / ₃₂ (2499)
	30 (762)	(Prefix)-30-HT24	52 ⁷ / ₃₂ (1326)	104 ¹³ / ₃₂ (2652)
	36 (914)	(Prefix)-36-HT24	55 ⁷ / ₃₂ (1402)	110 ¹³ / ₃₂ (2804)
36 (914)	6 (152)	(Prefix)-06-HT36	52 ⁷ / ₃₂ (1326)	104 ¹³ / ₃₂ (2652)
	9 (228)	(Prefix)-09-HT36	53 ¹¹ / ₁₆ (1364)	107 ¹³ / ₃₂ (2728)
	12 (305)	(Prefix)-12-HT36	55 ⁷ / ₃₂ (1402)	110 ¹³ / ₃₂ (2804)
	18 (457)	(Prefix)-18-HT36	58 ⁷ / ₃₂ (1478)	116 ¹³ / ₃₂ (2957)
	24 (609)	(Prefix)-24-HT36	61 ⁷ / ₃₂ (1554)	122 ¹³ / ₃₂ (3109)
	30 (762)	(Prefix)-30-HT36	64 ⁷ / ₃₂ (1631)	128 ¹³ / ₃₂ (3261)
	36 (914)	(Prefix)-36-HT36	67 ⁷ / ₃₂ (1707)	134 ¹³ / ₃₂ (3414)

For 3" Fittings

(Tray Widths - 6" thru 24" • Radius 12" only)
Polyester, Vinyl Ester
All are mitered

For 6" Fittings

(Tray Widths - 6" thru 36" • Radius 12", 24" & 36")
Polyester, Vinyl Ester
All radius are mitered

For 4" Fittings

(Tray Widths - 6" thru 36" • Radius 12", 24" & 36")
Polyester, Vinyl Ester
All radius are mitered

For 8" Fittings

(Tray Widths - 6" thru 36" • Radius 12", 24" & 36")
Polyester, Vinyl Ester
All radius are mitered

Dimensions shown in parentheses are in millimeters, unless otherwise specified.

Horizontal Cross (HX)

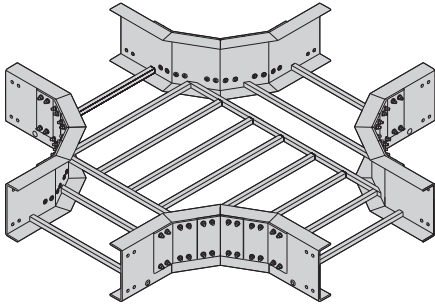

Three pair of splice plates with SS6 hardware required to connect to system.

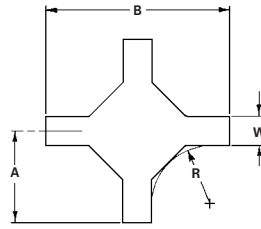

Mitered Cross

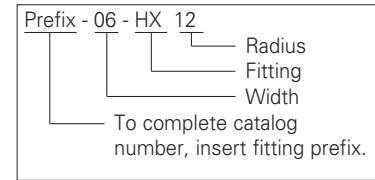

(Prefix) See page M-16 for catalog number prefix.
Dimensions for reference only, when critical contact factory.

- R - Bend Radius in. (mm)	Tray Width in. (mm)	Horizontal Cross - Mitered Dimensions		
		Catalog No.	A in. (mm)	B in. (mm)
12 (305)	6 (152)	(Prefix)-06-HX12	28 ³ / ₁₆ (716)	56 ¹³ / ₃₂ (1433)
	9 (228)	(Prefix)-09-HX12	29 ¹¹ / ₁₆ (754)	59 ¹³ / ₃₂ (1509)
	12 (305)	(Prefix)-12-HX12	31 ³ / ₁₆ (792)	62 ¹³ / ₃₂ (1585)
	18 (457)	(Prefix)-18-HX12	34 ³ / ₁₆ (869)	68 ¹³ / ₃₂ (1737)
	24 (609)	(Prefix)-24-HX12	37 ³ / ₁₆ (945)	74 ¹³ / ₃₂ (1890)
	30 (762)	(Prefix)-30-HX12	40 ³ / ₁₆ (1021)	80 ¹³ / ₃₂ (2042)
	36 (914)	(Prefix)-36-HX12	43 ³ / ₁₆ (1097)	86 ¹³ / ₃₂ (2195)
24 (609)	6 (152)	(Prefix)-06-HX24	40 ³ / ₁₆ (1021)	80 ¹³ / ₃₂ (2042)
	9 (228)	(Prefix)-09-HX24	41 ¹¹ / ₁₆ (1059)	83 ¹³ / ₃₂ (2118)
	12 (305)	(Prefix)-12-HX24	43 ³ / ₁₆ (1097)	86 ¹³ / ₃₂ (2195)
	18 (457)	(Prefix)-18-HX24	46 ³ / ₁₆ (1173)	92 ¹³ / ₃₂ (2347)
	24 (609)	(Prefix)-24-HX24	49 ³ / ₁₆ (1250)	98 ¹³ / ₃₂ (2499)
	30 (762)	(Prefix)-30-HX24	52 ³ / ₁₆ (1326)	104 ¹³ / ₃₂ (2652)
36 (914)	6 (152)	(Prefix)-06-HX36	52 ³ / ₁₆ (1326)	104 ¹³ / ₃₂ (2652)
	9 (228)	(Prefix)-09-HX36	53 ¹¹ / ₁₆ (1364)	107 ¹³ / ₃₂ (2728)
	12 (305)	(Prefix)-12-HX36	55 ³ / ₁₆ (1402)	110 ¹³ / ₃₂ (2804)
	18 (457)	(Prefix)-18-HX36	58 ³ / ₁₆ (1478)	116 ¹³ / ₃₂ (2957)
	24 (609)	(Prefix)-24-HX36	61 ³ / ₁₆ (1554)	122 ¹³ / ₃₂ (3109)
	30 (762)	(Prefix)-30-HX36	64 ³ / ₁₆ (1631)	128 ¹³ / ₃₂ (3261)
	36 (914)	(Prefix)-36-HX36	67 ³ / ₁₆ (1707)	134 ¹³ / ₃₂ (3414)

For 3" Fittings

(Tray Widths - 6" thru 24" • Radius 12" only)
Polyester, Vinyl Ester
All are mitered

For 6" Fittings

(Tray Widths - 6" thru 36"
Radius 12", 24" & 36")
Polyester, Vinyl Ester
All radius are mitered

For 4" Fittings

(Tray Widths - 6" thru 36"
Radius 12", 24" & 36")
Polyester, Vinyl Ester
All radius are mitered

For 8" Fittings

(Tray Widths - 6" thru 36"
Radius 12", 24" & 36")
Polyester, Vinyl Ester
All radius are mitered

Dimensions shown in parentheses are in millimeters, unless otherwise specified.

Reducers (LR) (SR) (RR)

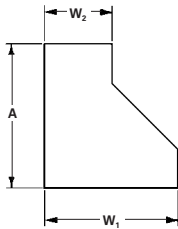
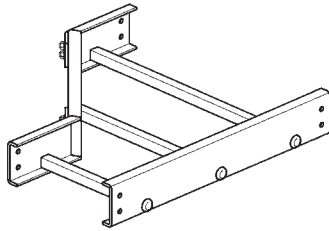

Left Reducer

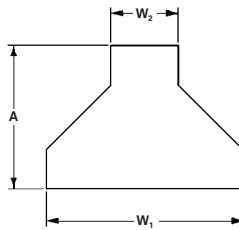
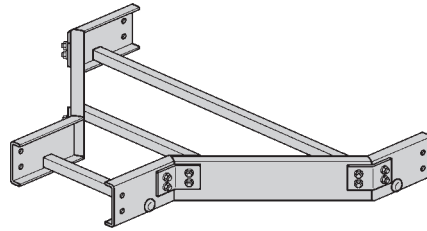

Straight Reducer

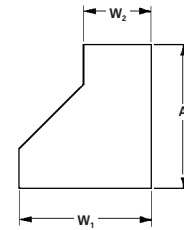
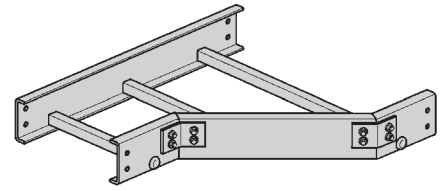

Right Reducer

One pair of splice plates with SS6 hardware required to connect to system.

3" Fittings

(Only available in W_1 widths of 9", 12", 18" & 24")

4", 6" & 8" Fittings

(Available in all W_1 widths shown in chart)

Polyester, Vinyl Ester
Available in all heights

Reducers are all of mitered construction.

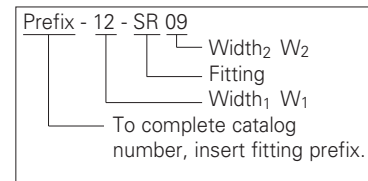

(Prefix) See page M-16 for catalog number prefix.
Dimensions for reference only, when critical contact factory.

Tray Width		Left Hand Reducer		Straight Reducer		Right Hand Reducer	
W_1 in. (mm)	W_2 in. (mm)	Catalog No.	A in. (mm)	Catalog No.	A in. (mm)	Catalog No.	A in. (mm)
9 (228)	6 (152)	(Prefix)-09-LR06	21 (533)	(Prefix)-09-SR06	19 1/2 (495)	(Prefix)-09-RR06	21 (533)
12 (305)	6 (152)	(Prefix)-12-LR06	24 (609)	(Prefix)-12-SR06	21 (533)	(Prefix)-12-RR06	24 (609)
	9 (228)	(Prefix)-12-LR09	21 (533)	(Prefix)-12-SR09	19 1/2 (495)	(Prefix)-12-RR09	21 (533)
18 (457)	6 (152)	(Prefix)-18-LR06	30 (762)	(Prefix)-18-SR06	24 (609)	(Prefix)-18-RR06	30 (762)
	9 (228)	(Prefix)-18-LR09	27 (686)	(Prefix)-18-SR09	22 1/2 (571)	(Prefix)-18-RR09	27 (686)
	12 (305)	(Prefix)-18-LR12	24 (609)	(Prefix)-18-SR12	21 (533)	(Prefix)-18-RR12	24 (609)
24 (609)	6 (152)	(Prefix)-24-LR06	36 (914)	(Prefix)-24-SR06	27 (686)	(Prefix)-24-RR06	36 (914)
	9 (228)	(Prefix)-24-LR09	33 (838)	(Prefix)-24-SR09	25 1/2 (648)	(Prefix)-24-RR09	33 (838)
	12 (305)	(Prefix)-24-LR12	30 (762)	(Prefix)-24-SR12	24 (609)	(Prefix)-24-RR12	30 (762)
	18 (457)	(Prefix)-24-LR18	24 (609)	(Prefix)-24-SR18	21 (533)	(Prefix)-24-RR18	24 (609)
30 (762)	6 (152)	(Prefix)-30-LR06	42 (1067)	(Prefix)-30-SR06	30 (762)	(Prefix)-30-RR06	42 (1067)
	9 (228)	(Prefix)-30-LR09	39 (990)	(Prefix)-30-SR09	28 1/2 (724)	(Prefix)-30-RR09	39 (990)
	12 (305)	(Prefix)-30-LR12	36 (914)	(Prefix)-30-SR12	27 (686)	(Prefix)-30-RR12	36 (914)
	18 (457)	(Prefix)-30-LR18	30 (762)	(Prefix)-30-SR18	24 (609)	(Prefix)-30-RR18	30 (762)
	24 (609)	(Prefix)-30-LR24	24 (609)	(Prefix)-30-SR24	21 (533)	(Prefix)-30-RR24	24 (609)
36 (914)	6 (152)	(Prefix)-36-LR06	48 (1219)	(Prefix)-36-SR06	33 (838)	(Prefix)-36-RR06	48 (1219)
	9 (228)	(Prefix)-36-LR09	45 (1143)	(Prefix)-36-SR09	31 1/2 (800)	(Prefix)-36-RR09	45 (1143)
	12 (305)	(Prefix)-36-LR12	42 (1067)	(Prefix)-36-SR12	30 (762)	(Prefix)-36-RR12	42 (1067)
	18 (457)	(Prefix)-36-LR18	36 (914)	(Prefix)-36-SR18	27 (686)	(Prefix)-36-RR18	36 (914)
	24 (609)	(Prefix)-36-LR24	30 (762)	(Prefix)-36-SR24	24 (609)	(Prefix)-36-RR24	30 (762)
	30 (762)	(Prefix)-36-LR30	24 (609)	(Prefix)-36-SR30	21 (533)	(Prefix)-36-RR30	24 (609)

Dimensions shown in parentheses are in millimeters, unless otherwise specified.

Horizontal Reducing Tee (HT)

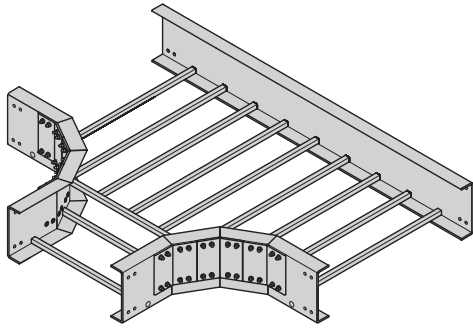

Two pair of splice plates with SS6 hardware required to connect to system.

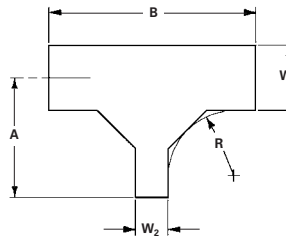

Mitered Reducing Tee

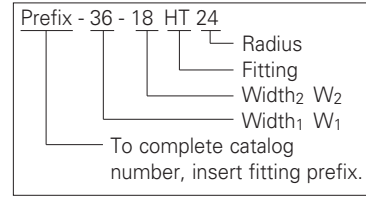

(Prefix) See page M-16 for catalog number prefix.
Dimensions for reference only, when critical contact factory.

Mitered Fittings

Tray Width		Catalog No. * Insert radius (12", 24" or 36")	12" Radius (305)		24" Radius (609)		36" Radius (914)	
W ₁ in. (mm)	W ₂ in. (mm)		A in. (mm)	B in. (mm)	A in. (mm)	B in. (mm)	A in. (mm)	B in. (mm)
9 (228)	6 (152)	(Prefix)-09-06-HT*	29 ¹¹ / ₁₆ (754)	56 ¹³ / ₃₂ (1433)	41 ¹¹ / ₁₆ (1059)	80 ¹³ / ₃₂ (2042)	53 ¹¹ / ₁₆ (1364)	104 ¹³ / ₃₂ (2652)
12 (305)	6 (152)	(Prefix)-12-06-HT*	31 ³ / ₁₆ (792)	56 ¹³ / ₃₂ (1433)	43 ³ / ₁₆ (1097)	80 ¹³ / ₃₂ (2042)	55 ³ / ₁₆ (1402)	104 ¹³ / ₃₂ (2652)
	9 (228)	(Prefix)-12-09-HT*	31 ³ / ₁₆ (792)	59 ¹³ / ₃₂ (1509)	43 ³ / ₁₆ (1097)	83 ¹³ / ₃₂ (2118)	55 ³ / ₁₆ (1402)	107 ¹³ / ₃₂ (2728)
18 (457)	6 (152)	(Prefix)-18-06-HT*	34 ³ / ₁₆ (869)	56 ¹³ / ₃₂ (1433)	46 ³ / ₁₆ (1173)	80 ¹³ / ₃₂ (2042)	58 ³ / ₁₆ (1478)	104 ¹³ / ₃₂ (2652)
	9 (228)	(Prefix)-18-09-HT*	34 ³ / ₁₆ (869)	59 ¹³ / ₃₂ (1509)	46 ³ / ₁₆ (1173)	83 ¹³ / ₃₂ (2118)	58 ³ / ₁₆ (1478)	107 ¹³ / ₃₂ (2728)
	12 (305)	(Prefix)-18-12-HT*	34 ³ / ₁₆ (869)	62 ¹³ / ₃₂ (1585)	46 ³ / ₁₆ (1173)	86 ¹³ / ₃₂ (2195)	58 ³ / ₁₆ (1478)	110 ¹³ / ₃₂ (2804)
24 (609)	6 (152)	(Prefix)-24-06-HT*	37 ³ / ₁₆ (945)	56 ¹³ / ₃₂ (1433)	49 ³ / ₁₆ (1250)	80 ¹³ / ₃₂ (2042)	61 ³ / ₁₆ (1554)	104 ¹³ / ₃₂ (2652)
	9 (228)	(Prefix)-24-09-HT*	37 ³ / ₁₆ (945)	59 ¹³ / ₃₂ (1509)	49 ³ / ₁₆ (1250)	83 ¹³ / ₃₂ (2118)	61 ³ / ₁₆ (1554)	107 ¹³ / ₃₂ (2728)
	12 (305)	(Prefix)-24-12-HT*	37 ³ / ₁₆ (945)	62 ¹³ / ₃₂ (1585)	49 ³ / ₁₆ (1250)	86 ¹³ / ₃₂ (2195)	61 ³ / ₁₆ (1554)	110 ¹³ / ₃₂ (2804)
	18 (457)	(Prefix)-24-18-HT*	37 ³ / ₁₆ (945)	68 ¹³ / ₃₂ (1737)	49 ³ / ₁₆ (1250)	92 ¹³ / ₃₂ (2347)	61 ³ / ₁₆ (1554)	116 ¹³ / ₃₂ (2957)
30 (762)	6 (152)	(Prefix)-30-06-HT*	40 ³ / ₁₆ (1021)	56 ¹³ / ₃₂ (1433)	52 ³ / ₁₆ (1326)	80 ¹³ / ₃₂ (2042)	64 ³ / ₁₆ (1631)	104 ¹³ / ₃₂ (2652)
	9 (228)	(Prefix)-30-09-HT*	40 ³ / ₁₆ (1021)	59 ¹³ / ₃₂ (1509)	52 ³ / ₁₆ (1326)	83 ¹³ / ₃₂ (2118)	64 ³ / ₁₆ (1631)	107 ¹³ / ₃₂ (2728)
	12 (305)	(Prefix)-30-12-HT*	40 ³ / ₁₆ (1021)	62 ¹³ / ₃₂ (1585)	52 ³ / ₁₆ (1326)	86 ¹³ / ₃₂ (2195)	64 ³ / ₁₆ (1631)	110 ¹³ / ₃₂ (2804)
	18 (457)	(Prefix)-30-18-HT*	40 ³ / ₁₆ (1021)	68 ¹³ / ₃₂ (1737)	52 ³ / ₁₆ (1326)	92 ¹³ / ₃₂ (2347)	64 ³ / ₁₆ (1631)	116 ¹³ / ₃₂ (2957)
	24 (609)	(Prefix)-30-24-HT*	40 ³ / ₁₆ (1021)	74 ¹³ / ₃₂ (1890)	52 ³ / ₁₆ (1326)	98 ¹³ / ₃₂ (2499)	64 ³ / ₁₆ (1631)	122 ¹³ / ₃₂ (3109)
36 (914)	6 (152)	(Prefix)-36-06-HT*	43 ³ / ₁₆ (1097)	56 ¹³ / ₃₂ (1433)	55 ³ / ₁₆ (1402)	80 ¹³ / ₃₂ (2042)	67 ³ / ₁₆ (1707)	104 ¹³ / ₃₂ (2652)
	9 (228)	(Prefix)-36-09-HT*	43 ³ / ₁₆ (1097)	59 ¹³ / ₃₂ (1509)	55 ³ / ₁₆ (1402)	83 ¹³ / ₃₂ (2118)	67 ³ / ₁₆ (1707)	107 ¹³ / ₃₂ (2728)
	12 (305)	(Prefix)-36-12-HT*	43 ³ / ₁₆ (1097)	62 ¹³ / ₃₂ (1585)	55 ³ / ₁₆ (1402)	86 ¹³ / ₃₂ (2195)	67 ³ / ₁₆ (1707)	110 ¹³ / ₃₂ (2804)
	18 (457)	(Prefix)-36-18-HT*	43 ³ / ₁₆ (1097)	68 ¹³ / ₃₂ (1737)	55 ³ / ₁₆ (1402)	92 ¹³ / ₃₂ (2347)	67 ³ / ₁₆ (1707)	116 ¹³ / ₃₂ (2957)
	24 (609)	(Prefix)-36-24-HT*	43 ³ / ₁₆ (1097)	74 ¹³ / ₃₂ (1890)	55 ³ / ₁₆ (1402)	98 ¹³ / ₃₂ (2499)	67 ³ / ₁₆ (1707)	122 ¹³ / ₃₂ (3109)
	30 (762)	(Prefix)-36-30-HT*	43 ³ / ₁₆ (1097)	80 ¹³ / ₃₂ (2042)	55 ³ / ₁₆ (1402)	104 ¹³ / ₃₂ (2652)	67 ³ / ₁₆ (1707)	128 ¹³ / ₃₂ (3261)

For 3" Fittings

(Radius 12" only
W₁ tray widths - 9", 12", 18" & 24")
Polyester, Vinyl Ester
All are mitered

For 4" Fittings

(Radius 12", 24" & 36"
W₁ tray widths - 9" thru 36")
Polyester, Vinyl Ester
All radius are mitered

For 6" Fittings

(Radius 12", 24" & 36"
W₁ tray widths - 9" thru 36")
Polyester, Vinyl Ester
All radius are mitered

For 8" Fittings

(Radius 12", 24" & 36"
W₁ tray widths - 9" thru 36")
Polyester, Vinyl Ester
All radius are mitered

Dimensions shown in parentheses are in millimeters, unless otherwise specified.

Horizontal Expanding Tee (HT)

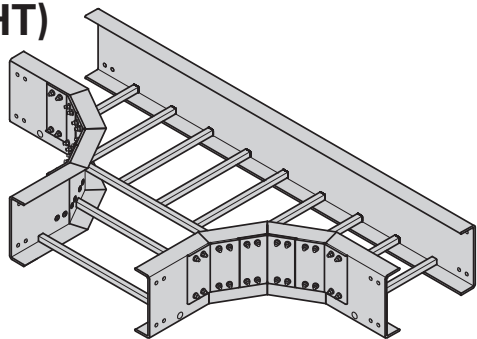

Two pair of splice plates with SS6 hardware required to connect to system.

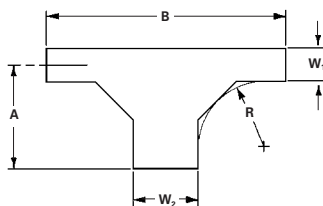

Mitered

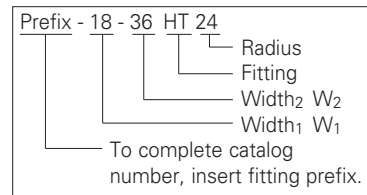

(Prefix) See page M-16 for catalog number prefix.
Dimensions for reference only, when critical contact factory.

Mitered Fittings

Tray Width		Catalog No. * Insert radius (12", 24" or 36")	12" Radius (305)		24" Radius (609)		36" Radius (914)	
W ₁ in. (mm)	W ₂ in. (mm)		A in. (mm)	B in. (mm)	A in. (mm)	B in. (mm)	A in. (mm)	B in. (mm)
6 (152)	9 (228)	(Prefix)-06-09-HT*	28 ³ / ₁₆ (716)	59 ¹³ / ₃₂ (1509)	40 ³ / ₁₆ (1021)	83 ¹³ / ₃₂ (2118)	52 ³ / ₁₆ (1326)	107 ¹³ / ₃₂ (2728)
	12 (305)	(Prefix)-06-12-HT*	28 ³ / ₁₆ (716)	62 ¹³ / ₃₂ (1585)	40 ³ / ₁₆ (1021)	86 ¹³ / ₃₂ (2195)	52 ³ / ₁₆ (1326)	110 ¹³ / ₃₂ (2804)
	18 (457)	(Prefix)-06-18-HT*	28 ³ / ₁₆ (716)	68 ¹³ / ₃₂ (1737)	40 ³ / ₁₆ (1021)	92 ¹³ / ₃₂ (2347)	52 ³ / ₁₆ (1326)	116 ¹³ / ₃₂ (2957)
	24 (609)	(Prefix)-06-24-HT*	28 ³ / ₁₆ (716)	74 ¹³ / ₃₂ (1890)	40 ³ / ₁₆ (1021)	98 ¹³ / ₃₂ (2499)	52 ³ / ₁₆ (1326)	122 ¹³ / ₃₂ (3109)
	30 (762)	(Prefix)-06-30-HT*	28 ³ / ₁₆ (716)	80 ¹³ / ₃₂ (2042)	40 ³ / ₁₆ (1021)	104 ¹³ / ₃₂ (2652)	52 ³ / ₁₆ (1326)	128 ¹³ / ₃₂ (3261)
	36 (914)	(Prefix)-06-36-HT*	28 ³ / ₁₆ (716)	86 ¹³ / ₃₂ (2195)	40 ³ / ₁₆ (1021)	110 ¹³ / ₃₂ (2804)	52 ³ / ₁₆ (1326)	134 ¹³ / ₃₂ (3414)
9 (228)	12 (305)	(Prefix)-09-12-HT*	29 ¹¹ / ₁₆ (754)	62 ¹³ / ₃₂ (1585)	41 ¹¹ / ₁₆ (1059)	86 ¹³ / ₃₂ (2195)	53 ¹¹ / ₁₆ (1364)	110 ¹³ / ₃₂ (2804)
	18 (457)	(Prefix)-09-18-HT*	29 ¹¹ / ₁₆ (754)	68 ¹³ / ₃₂ (1737)	41 ¹¹ / ₁₆ (1059)	92 ¹³ / ₃₂ (2347)	53 ¹¹ / ₁₆ (1364)	116 ¹³ / ₃₂ (2957)
	24 (609)	(Prefix)-09-24-HT*	29 ¹¹ / ₁₆ (754)	74 ¹³ / ₃₂ (1890)	41 ¹¹ / ₁₆ (1059)	98 ¹³ / ₃₂ (2499)	53 ¹¹ / ₁₆ (1364)	122 ¹³ / ₃₂ (3109)
	30 (762)	(Prefix)-09-30-HT*	29 ¹¹ / ₁₆ (754)	80 ¹³ / ₃₂ (2042)	41 ¹¹ / ₁₆ (1059)	104 ¹³ / ₃₂ (2652)	53 ¹¹ / ₁₆ (1364)	128 ¹³ / ₃₂ (3261)
	36 (914)	(Prefix)-09-36-HT*	29 ¹¹ / ₁₆ (754)	86 ¹³ / ₃₂ (2195)	41 ¹¹ / ₁₆ (1059)	110 ¹³ / ₃₂ (2804)	53 ¹¹ / ₁₆ (1364)	134 ¹³ / ₃₂ (3414)
12 (305)	18 (457)	(Prefix)-12-18-HT*	31 ³ / ₁₆ (792)	68 ¹³ / ₃₂ (1737)	43 ³ / ₁₆ (1097)	92 ¹³ / ₃₂ (2347)	55 ³ / ₁₆ (1402)	116 ¹³ / ₃₂ (2957)
	24 (609)	(Prefix)-12-24-HT*	31 ³ / ₁₆ (792)	74 ¹³ / ₃₂ (1890)	43 ³ / ₁₆ (1097)	98 ¹³ / ₃₂ (2499)	55 ³ / ₁₆ (1402)	122 ¹³ / ₃₂ (3109)
	30 (762)	(Prefix)-12-30-HT*	31 ³ / ₁₆ (792)	80 ¹³ / ₃₂ (2042)	43 ³ / ₁₆ (1097)	104 ¹³ / ₃₂ (2652)	55 ³ / ₁₆ (1402)	128 ¹³ / ₃₂ (3261)
	36 (914)	(Prefix)-12-36-HT*	31 ³ / ₁₆ (792)	86 ¹³ / ₃₂ (2195)	43 ³ / ₁₆ (1097)	110 ¹³ / ₃₂ (2804)	55 ³ / ₁₆ (1402)	134 ¹³ / ₃₂ (3414)
18 (457)	24 (609)	(Prefix)-18-24-HT*	34 ³ / ₁₆ (869)	74 ¹³ / ₃₂ (1890)	46 ³ / ₁₆ (1173)	98 ¹³ / ₃₂ (2499)	58 ³ / ₁₆ (1478)	122 ¹³ / ₃₂ (3109)
	30 (762)	(Prefix)-18-30-HT*	34 ³ / ₁₆ (869)	80 ¹³ / ₃₂ (2042)	46 ³ / ₁₆ (1173)	104 ¹³ / ₃₂ (2652)	58 ³ / ₁₆ (1478)	128 ¹³ / ₃₂ (3261)
	36 (914)	(Prefix)-18-36-HT*	34 ³ / ₁₆ (869)	86 ¹³ / ₃₂ (2195)	46 ³ / ₁₆ (1173)	110 ¹³ / ₃₂ (2804)	58 ³ / ₁₆ (1478)	134 ¹³ / ₃₂ (3414)
24 (609)	30 (762)	(Prefix)-24-30-HT*	37 ³ / ₁₆ (945)	80 ¹³ / ₃₂ (2042)	49 ³ / ₁₆ (1250)	104 ¹³ / ₃₂ (2652)	61 ³ / ₁₆ (1554)	128 ¹³ / ₃₂ (3261)
	36 (914)	(Prefix)-24-36-HT*	37 ³ / ₁₆ (945)	86 ¹³ / ₃₂ (2195)	49 ³ / ₁₆ (1250)	110 ¹³ / ₃₂ (2804)	61 ³ / ₁₆ (1554)	134 ¹³ / ₃₂ (3414)
30 (762)	36 (914)	(Prefix)-30-36-HT*	40 ³ / ₁₆ (1021)	86 ¹³ / ₃₂ (2195)	52 ³ / ₁₆ (1326)	110 ¹³ / ₃₂ (2804)	64 ³ / ₁₆ (1631)	134 ¹³ / ₃₂ (3414)

For 3" Fittings

(Radius 12" only)
W₁ tray widths - 6" thru 18"
W₂ tray widths - 9" thru 24"
Polyester, Vinyl Ester
All are mitered

For 4" Fittings

(Radius 12", 24" & 36")
W₁ tray widths - 6" thru 30"
W₂ tray widths - 9" thru 36"
Polyester, Vinyl Ester
All radius are mitered

For 6" Fittings

(Radius 12", 24" & 36")
W₁ tray widths - 6" thru 30"
W₂ tray widths - 9" thru 36"
Polyester, Vinyl Ester
All radius are mitered

For 8" Fittings

(Radius 12", 24" & 36")
W₁ tray widths - 6" thru 30"
W₂ tray widths - 9" thru 36"
Polyester, Vinyl Ester
All radius are mitered

Dimensions shown in parentheses are in millimeters, unless otherwise specified.

Horizontal Expanding/Reducing Cross (HX)

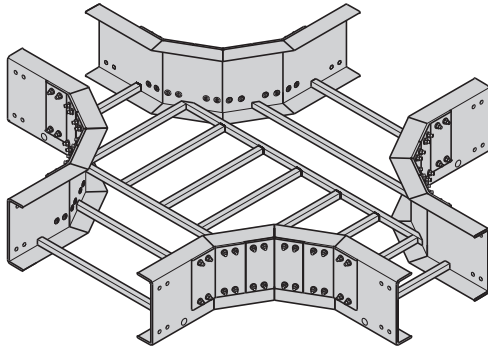

Three pair of splice plates with SS6 hardware required to connect to system.

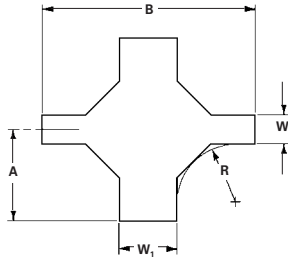

Mitered

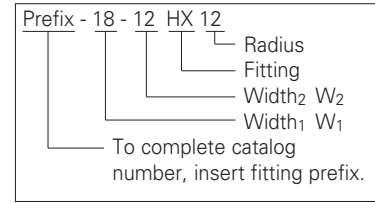

(Prefix) See page M-16 for catalog number prefix.
Dimensions for reference only, when critical contact factory.

Mitered Fittings

Tray Width		Catalog No. * Insert radius (12", 24" or 36")	12" Radius (305)		24" Radius (609)		36" Radius (914)	
W ₁ in. (mm)	W ₂ in. (mm)		A in. (mm)	B in. (mm)	A in. (mm)	B in. (mm)	A in. (mm)	B in. (mm)
9 (228)	6 (152)	(Prefix)-09-06-HX*	28 ³ / ₁₆ (716)	59 ¹³ / ₃₂ (1509)	40 ³ / ₁₆ (1021)	83 ¹³ / ₃₂ (2118)	52 ³ / ₁₆ (1326)	107 ¹³ / ₃₂ (2728)
12 (305)	6 (152)	(Prefix)-12-06-HX*	28 ³ / ₁₆ (716)	62 ¹³ / ₃₂ (1585)	40 ³ / ₁₆ (1021)	86 ¹³ / ₃₂ (2195)	52 ³ / ₁₆ (1326)	110 ¹³ / ₃₂ (2804)
	9 (228)	(Prefix)-12-09-HX*	29 ¹¹ / ₁₆ (754)	62 ¹³ / ₃₂ (1585)	41 ¹¹ / ₁₆ (1059)	86 ¹³ / ₃₂ (2195)	53 ¹¹ / ₁₆ (1364)	110 ¹³ / ₃₂ (2804)
18 (457)	6 (152)	(Prefix)-18-06-HX*	28 ³ / ₁₆ (716)	68 ¹³ / ₃₂ (1737)	40 ³ / ₁₆ (1021)	92 ¹³ / ₃₂ (2347)	52 ³ / ₁₆ (1326)	116 ¹³ / ₃₂ (2957)
	9 (228)	(Prefix)-18-09-HX*	29 ¹¹ / ₁₆ (754)	68 ¹³ / ₃₂ (1737)	41 ¹¹ / ₁₆ (1059)	92 ¹³ / ₃₂ (2347)	53 ¹¹ / ₁₆ (1364)	116 ¹³ / ₃₂ (2957)
	12 (305)	(Prefix)-18-12-HX*	31 ³ / ₁₆ (792)	68 ¹³ / ₃₂ (1737)	43 ³ / ₁₆ (1097)	92 ¹³ / ₃₂ (2347)	55 ³ / ₁₆ (1402)	116 ¹³ / ₃₂ (2957)
24 (609)	6 (152)	(Prefix)-24-06-HX*	28 ³ / ₁₆ (716)	74 ¹³ / ₃₂ (1890)	40 ³ / ₁₆ (1021)	98 ¹³ / ₃₂ (2499)	52 ³ / ₁₆ (1326)	122 ¹³ / ₃₂ (3109)
	9 (228)	(Prefix)-24-09-HX*	29 ¹¹ / ₁₆ (754)	74 ¹³ / ₃₂ (1890)	41 ¹¹ / ₁₆ (1059)	98 ¹³ / ₃₂ (2499)	53 ¹¹ / ₁₆ (1364)	122 ¹³ / ₃₂ (3109)
	12 (305)	(Prefix)-24-12-HX*	31 ³ / ₁₆ (792)	74 ¹³ / ₃₂ (1890)	43 ³ / ₁₆ (1097)	98 ¹³ / ₃₂ (2499)	55 ³ / ₁₆ (1402)	122 ¹³ / ₃₂ (3109)
	18 (457)	(Prefix)-24-18-HX*	34 ³ / ₁₆ (869)	74 ¹³ / ₃₂ (1890)	46 ³ / ₁₆ (1173)	98 ¹³ / ₃₂ (2499)	58 ³ / ₁₆ (1478)	122 ¹³ / ₃₂ (3109)
30 (762)	6 (152)	(Prefix)-30-06-HX*	28 ³ / ₁₆ (716)	80 ¹³ / ₃₂ (2042)	40 ³ / ₁₆ (1021)	104 ¹³ / ₃₂ (2652)	52 ³ / ₁₆ (1326)	128 ¹³ / ₃₂ (3261)
	9 (228)	(Prefix)-30-09-HX*	29 ¹¹ / ₁₆ (754)	80 ¹³ / ₃₂ (2042)	41 ¹¹ / ₁₆ (1059)	104 ¹³ / ₃₂ (2652)	53 ¹¹ / ₁₆ (1364)	128 ¹³ / ₃₂ (3261)
	12 (305)	(Prefix)-30-12-HX*	31 ³ / ₁₆ (792)	80 ¹³ / ₃₂ (2042)	43 ³ / ₁₆ (1097)	104 ¹³ / ₃₂ (2652)	55 ³ / ₁₆ (1402)	128 ¹³ / ₃₂ (3261)
	18 (457)	(Prefix)-30-18-HX*	34 ³ / ₁₆ (869)	80 ¹³ / ₃₂ (2042)	46 ³ / ₁₆ (1173)	104 ¹³ / ₃₂ (2652)	58 ³ / ₁₆ (1478)	128 ¹³ / ₃₂ (3261)
	24 (609)	(Prefix)-30-24-HX*	37 ³ / ₁₆ (945)	80 ¹³ / ₃₂ (2042)	49 ³ / ₁₆ (1250)	104 ¹³ / ₃₂ (2652)	61 ³ / ₁₆ (1554)	128 ¹³ / ₃₂ (3261)
36 (914)	6 (152)	(Prefix)-36-06-HX*	28 ³ / ₁₆ (716)	86 ¹³ / ₃₂ (2195)	40 ³ / ₁₆ (1021)	110 ¹³ / ₃₂ (2804)	52 ³ / ₁₆ (1326)	134 ¹³ / ₃₂ (3414)
	9 (228)	(Prefix)-36-09-HX*	29 ¹¹ / ₁₆ (754)	86 ¹³ / ₃₂ (2195)	41 ¹¹ / ₁₆ (1059)	110 ¹³ / ₃₂ (2804)	53 ¹¹ / ₁₆ (1364)	134 ¹³ / ₃₂ (3414)
	12 (305)	(Prefix)-36-12-HX*	31 ³ / ₁₆ (792)	86 ¹³ / ₃₂ (2195)	43 ³ / ₁₆ (1097)	110 ¹³ / ₃₂ (2804)	55 ³ / ₁₆ (1402)	134 ¹³ / ₃₂ (3414)
	18 (457)	(Prefix)-36-18-HX*	34 ³ / ₁₆ (869)	86 ¹³ / ₃₂ (2195)	46 ³ / ₁₆ (1173)	110 ¹³ / ₃₂ (2804)	58 ³ / ₁₆ (1478)	134 ¹³ / ₃₂ (3414)
	24 (609)	(Prefix)-36-24-HX*	37 ³ / ₁₆ (945)	86 ¹³ / ₃₂ (2195)	49 ³ / ₁₆ (1250)	110 ¹³ / ₃₂ (2804)	61 ³ / ₁₆ (1554)	134 ¹³ / ₃₂ (3414)
	30 (762)	(Prefix)-36-30-HX*	40 ³ / ₁₆ (1021)	86 ¹³ / ₃₂ (2195)	52 ³ / ₁₆ (1326)	110 ¹³ / ₃₂ (2804)	64 ³ / ₁₆ (1631)	134 ¹³ / ₃₂ (3414)

For 3" Fittings

(Radius 12" only)
W₁ tray widths - 9" thru 24"
W₂ tray widths - 6" thru 18"
Polyester, Vinyl Ester
All are mitered

For 4" Fittings

(Radius 12", 24" & 36")
W₁ tray widths - 9" thru 36"
W₂ tray widths - 6" thru 30"
Polyester, Vinyl Ester
All radius are mitered

For 6" Fittings

(Radius 12", 24" & 36")
W₁ tray widths - 9" thru 36"
W₂ tray widths - 6" thru 30"
Polyester, Vinyl Ester
All radius are mitered

For 8" Fittings

(Radius 12", 24" & 36")
W₁ tray widths - 9" thru 36"
W₂ tray widths - 6" thru 30"
Polyester, Vinyl Ester
All radius are mitered

Dimensions shown in parentheses are in millimeters, unless otherwise specified.

Fiberglass - Fittings

Vertical Bends 90° (VO) (VI)

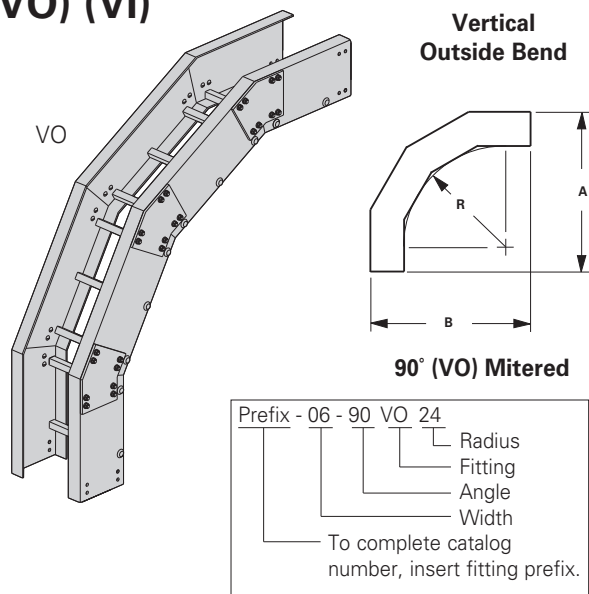

One pair of splice plates with SS6 hardware required to connect to system.

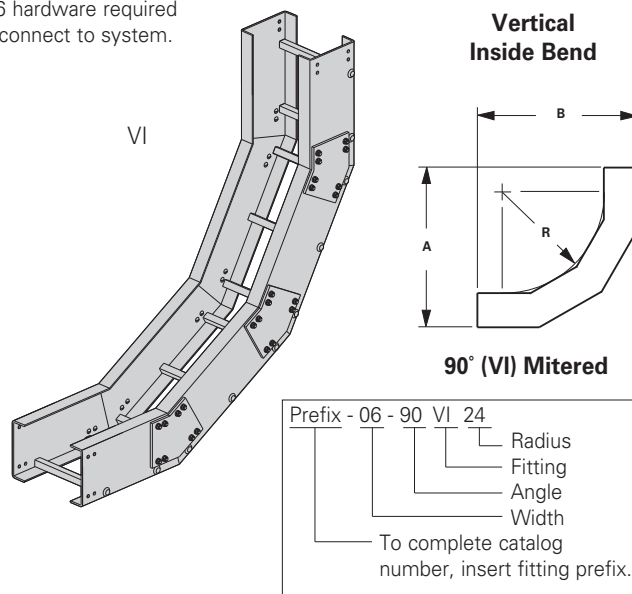

(Prefix) See page M-16 for catalog number prefix. Dimensions for reference only, when critical contact factory.

- R - Bend Radius in. (mm)	Tray Width in. (mm)	90° Mitered		
		Catalog No.	VO & VI Bend	
			A in. / (mm)	B in. / (mm)
12 (305)	6 (152)	(Prefix)-06-90(*)12	27 ⁵ / ₃₂ (690)	27 ⁵ / ₃₂ (690)
	9 (228)	(Prefix)-09-90(*)12		
	12 (305)	(Prefix)-12-90(*)12		
	18 (457)	(Prefix)-18-90(*)12		
	24 (609)	(Prefix)-24-90(*)12		
	36 (914)	(Prefix)-36-90(*)12		
24 (609)	6 (152)	(Prefix)-06-90(*)24	36 ²³ / ₃₂ (933)	36 ²³ / ₃₂ (933)
	9 (228)	(Prefix)-09-90(*)24		
	12 (305)	(Prefix)-12-90(*)24		
	18 (457)	(Prefix)-18-90(*)24		
	24 (609)	(Prefix)-24-90(*)24		
	36 (914)	(Prefix)-36-90(*)24		
36 (914)	6 (152)	(Prefix)-06-90(*)36	44 ²⁹ / ₃₂ (1141)	44 ²⁹ / ₃₂ (1141)
	9 (228)	(Prefix)-09-90(*)36		
	12 (305)	(Prefix)-12-90(*)36		
	18 (457)	(Prefix)-18-90(*)36		
	24 (609)	(Prefix)-24-90(*)36		
	36 (914)	(Prefix)-36-90(*)36		

For 3" Fittings
(Radius 12" only • Tray widths - 6" thru 24")
Polyester, Vinyl Ester
All are mitered

For 4" Fittings
(Radius 12", 24" & 36"
Tray widths - 6" thru 36")
Polyester, Vinyl Ester
All radius are mitered

For 6" Fittings
(Radius 12", 24" & 36"
Tray widths - 6" thru 36")
Polyester, Vinyl Ester
All radius are mitered

For 8" Fittings
(Radius 12", 24" & 36"
Tray widths - 6" thru 36")
Polyester, Vinyl Ester
All radius are mitered

(*) Insert 'VO' for Vertical Outside Bend or 'VI' for Vertical Inside Bend.

Dimensions shown in parentheses are in millimeters, unless otherwise specified.

Vertical Outside Bend

VO

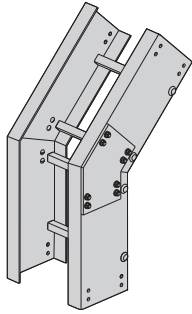

One pair of splice plates with SS6 hardware required to connect to system.

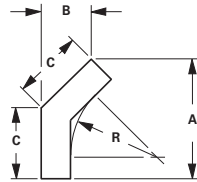

45° (VO) Mitered

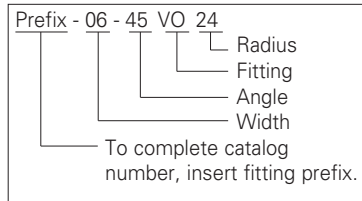

Vertical Inside Bend

VI

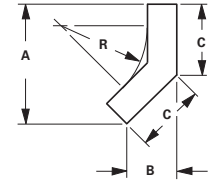
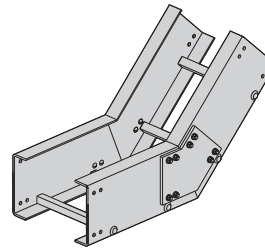

45° (VI) Mitered

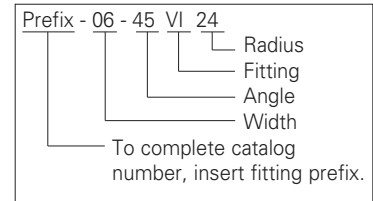

(Prefix) See page M-16 for catalog number prefix. Dimensions for reference only, when critical contact factory.

- R - Bend Radius in. mm	Tray Width in. mm	45° Mitered			
		Catalog No.	VO & VI Bend		
			A in. / (mm)	B in. / (mm)	C in. / (mm)
12 (305)	6 (152)	(Prefix)-06-45(*)12	23 ¹ / ₁₆ (585)	9 ⁹ / ₁₆ (242)	13 ¹ / ₂ (343)
	9 (228)	(Prefix)-09-45(*)12			
	12 (305)	(Prefix)-12-45(*)12			
	18 (457)	(Prefix)-18-45(*)12			
	24 (609)	(Prefix)-24-45(*)12			
	30 (762)	(Prefix)-30-45(*)12			
36 (914)	(Prefix)-36-45(*)12				
24 (609)	6 (152)	(Prefix)-06-45(*)24	23 ¹ / ₁₆ (585)	9 ⁹ / ₁₆ (242)	13 ¹ / ₂ (343)
	9 (228)	(Prefix)-09-45(*)24			
	12 (305)	(Prefix)-12-45(*)24			
	18 (457)	(Prefix)-18-45(*)24			
	24 (609)	(Prefix)-24-45(*)24			
	30 (762)	(Prefix)-30-45(*)24			
36 (914)	(Prefix)-36-45(*)24				
36 (914)	6 (152)	(Prefix)-06-45(*)36	23 ¹ / ₁₆ (585)	9 ⁹ / ₁₆ (242)	13 ¹ / ₂ (343)
	9 (228)	(Prefix)-09-45(*)36			
	12 (305)	(Prefix)-12-45(*)36			
	18 (457)	(Prefix)-18-45(*)36			
	24 (609)	(Prefix)-24-45(*)36			
	30 (762)	(Prefix)-30-45(*)36			
36 (914)	(Prefix)-36-45(*)36				

For 3" Fittings

(Radius 12" only)
Tray widths - 6" thru 24"
Polyester, Vinyl Ester
All are mitered

For 4" Fittings

(Radius 12", 24" & 36"
Tray widths - 6" thru 36"
Polyester, Vinyl Ester
All radius are mitered

For 6" Fittings

(Radius 12", 24" & 36"
Tray widths - 6" thru 36"
Polyester, Vinyl Ester
All radius are mitered

For 8" Fittings

(Radius 12", 24" & 36"
Tray widths - 6" thru 36"
Polyester, Vinyl Ester
All radius are mitered

(*) Insert 'VO' for Vertical Outside Bend or 'VI' for Vertical Inside Bend.
60° and 30° vertical bends available in mitered construction.

Dimensions shown in parentheses are in millimeters, unless otherwise specified.

Fiberglass - Covers & Cover Accessories

Covers

Material Thickness: .090" (2.3)

Cover Length: 10' (3m)

Standard Mounting Hardware: (10 each) #10 x 3/4" stainless, self drilling screws provided with each section

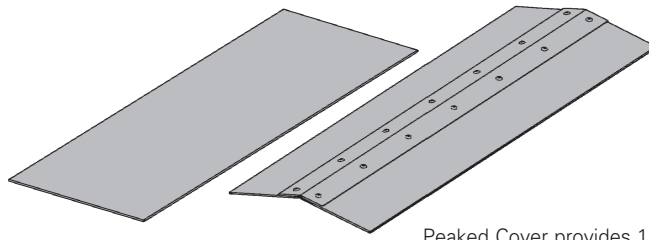

Peaked Cover provides 1 to 3.7 pitch
Peaked covers available for straight sections only.
No Hardware provided.

Covers

	F	C	-	24	-	120	
							Length or fitting description
							Width
							Rail design
							Material
●	F	C	-	24	-	120	= Flat polyester
●	FV	C	-	24	-	120	= Flat vinyl ester
●	FP	C	-	24	-	120	= Peaked polyester
●	FVP	C	-	24	-	120	= Peaked vinyl ester

Quantity of Standard Cover Clamps Required

Straight Section 60" or 72"	4 pcs.
Straight Section 120" or 144"	6 pcs.
Horizontal/Vertical Bends	4 pcs.
Tees	6 pcs.
Crosses	8 pcs.

Note: When using the Heavy Duty Cover Clamp, only one-half the number of clamps stated above is required.

Standard Cover Clamp

- Furnished in pairs with hardware.

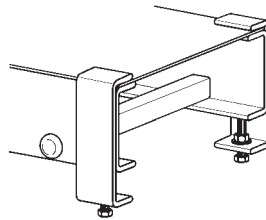

Catalog No.	Side Rail Height	
	in.	(mm)
9(Δ)-9013	3	(76)
9(Δ)-9014	4	(101)
9(Δ)-9016	6	(152)

Heavy Duty Cover Clamp

Recommended for outdoor service.

- W = tray width
- Heavy duty cover clamp available for flat covers only

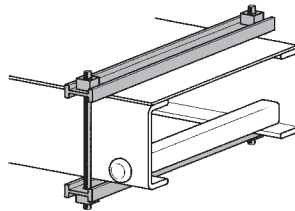

Catalog No.	Side Rail Height	
	in.	(mm)
9F-W-9034	3	(76)
9F-W-9044	4	(101)
9F-W-9064	6	(152)
9F-W-9084	8	(203)

Peaked Cover Clamp

- W = tray width

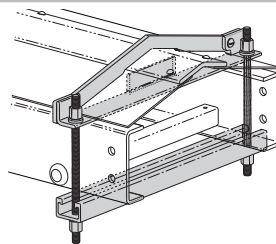

Catalog No.	Side Rail Height	
	in.	(mm)
9F-W-9034P	3	(76)
9F-W-9044P	4	(101)
9F-W-9064P	6	(152)
9F-W-9084P	8	(203)

Thermo Plastic Drive Rivet

- Sold individually.
- Shipped in packages of 25 pcs.

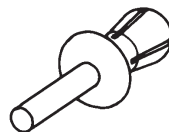

Catalog No.

- TPDR

Material Designations

(Δ) Insert one of the following material designations when required.

- F = Polyester Resin (Example: 9F-9013) available for all side rail heights
- FV = Vinyl Ester Resin (Example: 9FV-9013) available for all side rail heights

● Green = Fastest shipped items ● Black = Normal lead-time items ● Red = Normally long lead-time items

Dimensions shown in parentheses are in millimeters, unless otherwise specified.

Part Number with Hardware Explanation

Note: All hardware is 3/8"

Example: 9F-4004 SS6: pair of 4-hole splice plates for 4" (101) system with stainless steel hardware

9FV-8006 SS6: pair of 8-hole vinyl ester splice plates for 6" (152) system with stainless steel hardware

Hardware Option	316 Stainless Steel
	SS6

Standard Lay-In Splice Plates

- Furnished in pairs with 316 stainless steel hardware
- One pair including hardware provided with straight section. (Expansion splice quantity subtracted)

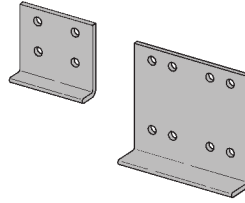

Material	Height in. (mm)	Catalog No.
Fiberglass	3" (76)	9(Δ)-4003SS6
	4" (101)	9(Δ)-4004SS6
	6" (152)	9(Δ)-8006SS6
	8" (203)	9(Δ)-8008SS6

Expansion Lay-In Splice Plates

- Furnished in pairs with 316 stainless steel hardware

Requires supports within 24" on both sides, per NEMA VE 2.

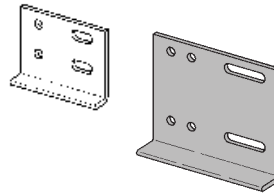

Material	Height in. (mm)	Catalog No.
Fiberglass	3" (76)	9(Δ)-4013SS6
	4" (101)	9(Δ)-4014SS6
	6" (152)	9(Δ)-8016SS6
	8" (203)	9(Δ)-8018SS6

Tray to Box Splice Plates

These plates are used to attach the end of a tray run to a distribution box or control center.

- Furnished in pairs with 316 stainless steel hardware

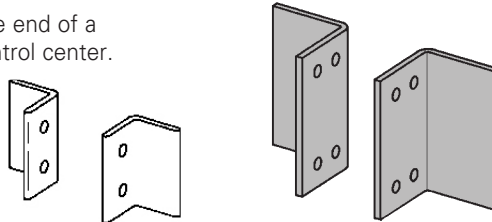

Material	Height in. (mm)	Catalog No.
Fiberglass	3" (76)	9(Δ)-4053SS6
	4" (101)	9(Δ)-4054SS6
	6" (152)	9(Δ)-8056SS6
	8" (203)	9(Δ)-8058SS6

Step Down Splice Plates

These plates are offered for connecting cable tray sections having side rails of different heights.

- Furnished in pairs with 316 stainless steel hardware

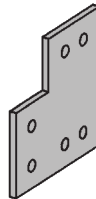

Material	Height in. (mm)	Catalog No.
Fiberglass	8" to 6" (203 to 152)	9(Δ)-8086SS6
	8" to 4" (203 to 101)	9(Δ)-8084SS6
	6" to 3" (152 to 76)	9(Δ)-8063SS6
	6" to 4" (152 to 101)	9(Δ)-8064SS6
	4" to 3" (101 to 76)	9(Δ)-4043SS6

Blind End Plate

This plate forms a closure for any tray that dead ends.

- Furnished as one plate
- W = tray width

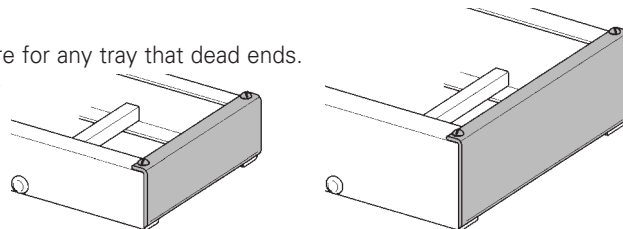

Material	Height in. (mm)	Catalog No.
Fiberglass	3" (76)	9(Δ)-1083-WSS6
	4" (101)	9(Δ)-1084-WSS6
	6" (152)	9(Δ)-1086-WSS6
	8" (203)	9(Δ)-1088-WSS6

Resin Seal Kit

To reseal fiberglass after field modifications.

- 1 pint (473ml)

Contents: Sealant and Applicator.



Catalog No.
RSK-010

(Δ) See page M-31 for material selection

Dimensions shown in parentheses are in millimeters, unless otherwise specified.

Horizontal Adjustable Splice Plates

These plates provide for changes in the horizontal direction that do not conform to standard fittings.

- Furnished in pairs with 316 stainless steel hardware
- Body made from 316 stainless steel
- Used for all material finishes

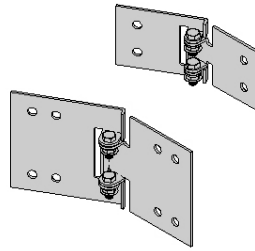

Material	Height in. (mm)	Catalog No.
316SS	3" (76)	9F-4033SS6
	4" (101)	9F-4034SS6
	6" (152)	9F-8036SS6
	8" (203)	9F-8038SS6

Horizontal Splice Plates

- Furnished in pairs with 316 stainless steel hardware

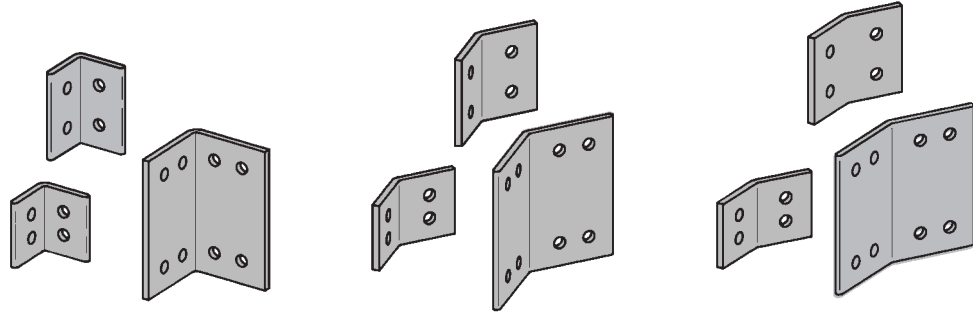

Material	Height in. (mm)	90°	Catalog No. 45°	30°
Fiberglass	3" (76)	9(Δ)-4903HSS6	9(Δ)-4453HSS6	9(Δ)-4303HSS6
	4" (101)	9(Δ)-4904HSS6	9(Δ)-4454HSS6	9(Δ)-4304HSS6
	6" (152)	9(Δ)-8906HSS6	9(Δ)-8456HSS6	9(Δ)-8306HSS6
	8" (203)	9(Δ)-8908HSS6	9(Δ)-8458HSS6	9(Δ)-8308HSS6

Vertical Adjustable Splice Plates

These plates provide for changes in elevation that do not conform to standard vertical fittings.

- Furnished in pairs with 316 stainless steel hardware

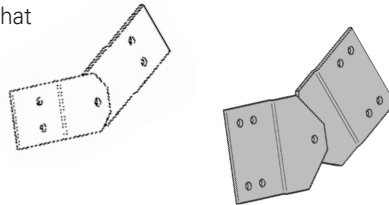

Material	Height in. (mm)	Catalog No.
Fiberglass	3" (76)	9(Δ)-4023SS6
	4" (101)	9(Δ)-4024SS6
	6" (152)	9(Δ)-8026SS6
	8" (203)	9(Δ)-8028SS6

Vertical Splice Plates

- Furnished in pairs with 316 stainless steel hardware

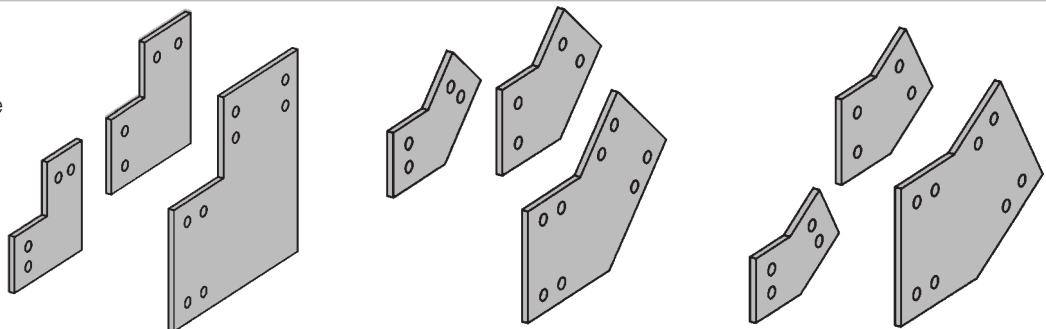

Material	Height in. (mm)	90°	Catalog No. 45°	30°
Fiberglass	3" (76)	9(Δ)-4903VSS6	9(Δ)-4453VSS6	9(Δ)-4303VSS6
	4" (101)	9(Δ)-4904VSS6	9(Δ)-4454VSS6	9(Δ)-4304VSS6
	6" (152)	9(Δ)-8906VSS6	9(Δ)-8456VSS6	9(Δ)-8306VSS6
	8" (203)	9(Δ)-8908VSS6	9(Δ)-8458VSS6	9(Δ)-8308VSS6

(Δ) See page M-31 for material selection

Dimensions shown in parentheses are in millimeters, unless otherwise specified.

Fiberglass

Ladder Drop-Out

Specially-designed Ladder Drop-Outs provide a rounded surface with adequate radius to protect cable as it exits from the tray, preventing damage to insulation.

- 4" (101) radius
- W = tray width
- Furnished with #10 x 3/4" self-drilling stainless steel screws

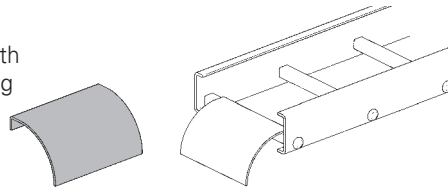

Catalog No.
9(Δ)-1104-W

Barriers

- Furnished with #10 x 3/4" self-drilling stainless steel screws

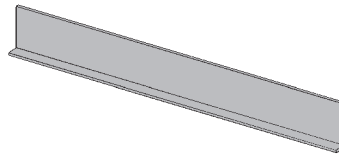

Catalog No.	Side Rail Height
	in. (mm)
72(Δ)-120	3" (76)
73(Δ)-120	4" (101)
75(Δ)-120	6" (152)
77(Δ)-120	8" (203)

Flexible Horizontal Barrier Kit

One kit allows up to a 36" (914) radius position of the barrier.

Kit Contents:

- 1 pc — 72" (1829) Straight Barrier
 - 4 pc — 9F-9002 Barrier Strip Clip
 - 8 pc — Thermo Plastic Drive Rivet
 - 4 pc — #10 x 3/4" Stainless Steel Self-Drilling Screw
- Assembly required — directions included.

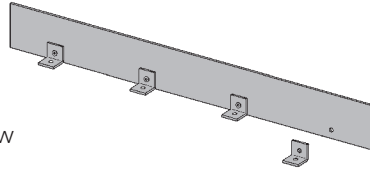

Catalog No.	Side Rail Height
	in. (mm)
72(Δ)-90HBFL	3" (76)
73(Δ)-90HBFL	4" (101)
75(Δ)-90HBFL	6" (152)
77(Δ)-90HBFL	8" (203)

Vertical Bend Barriers

- Furnished with #10 x 3/4" self-drilling stainless steel screws
- * Insert 2 for 3" (76) siderail height
- 3 for 4" (101) siderail height
- 5 for 6" (152) siderail height

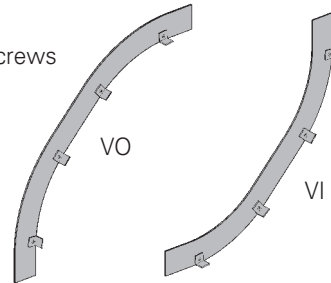

7* (Δ) - 90 VO 24	
	Radius
	VI or VO
	Angle
	Material
	Barrier Size

Clamp/Guide - Fiberglass

- Nonmetallic
- Designed for 3/8" hardware - not included
- Combination hold down clamp and guide
- Material: Glass reinforced polyurethane
- Sold in pairs

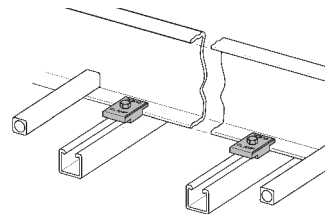

Catalog No.
9F-1208

Fiberglass Conduit to Cable Tray Adapter

- For rigid or PVC conduit
- Furnished in pairs with 316 stainless steel hardware

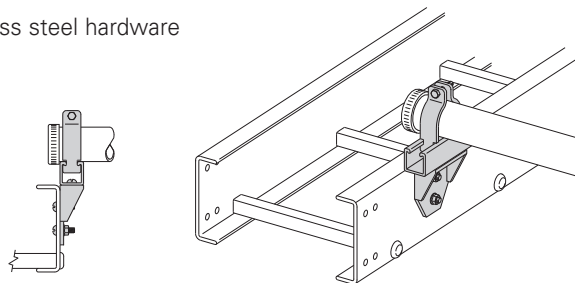

Catalog No.	Conduit Size
	in. (mm)
9FV-2008	0.50 (15)
9FV-2009	0.75 (20)
9FV-2010	1.00 (25)
9FV-2011	1.25 (32)
9FV-2012	1.50 (40)
9FV-2013	2.00 (50)
9FV-2014	2.50 (65)
9FV-2015	3.00 (80)
9FV-2016	3.50 (90)
9FV-2017	4.00 (100)

(Δ) See page M-27 for material selection

Dimensions shown in parentheses are in millimeters, unless otherwise specified.

Fiberglass - Cable Channel & Fittings

Straight Section

- Load data was interpolated from CSA testing.
- Loads shown are for FCCN series.
- Loads shown are for 6 ft. (1.83m) span with deflection of .7 (18.26) inches.
- One pair of splice plates included with each straight section.

FCC Fiberglass
Cable Channel Ventilated

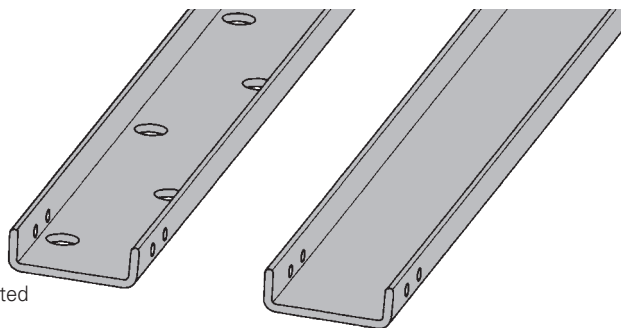

FCCN Fiberglass Cable
Channel Non-Ventilated

Catalog No.		Width in. (mm)	Length ft. (m)	Height in. (mm)	Load Lbs/Ft (kg/m)
Ventilated	Non-Ventilated				
(*)-03-120	(*)N-03-120	3 (76)	10 (3)	1 (25)	8 (12)
(*)-03-240	(*)N-03-240	3 (76)	20 (6)	1 (25)	8 (12)
(*)-04-120	(*)N-04-120	4 (101)	10 (3)	1 1/8 (28)	12 (18)
(*)-04-240	(*)N-04-240	4 (101)	20 (6)	1 1/8 (28)	12 (18)
(*)-06-120	(*)N-06-120	6 (152)	10 (3)	1 5/8 (35)	58 (86)
(*)-06-240	(*)N-06-240	6 (152)	20 (6)	1 5/8 (35)	58 (86)
(*)-08-120	(*)N-08-120	8 (203)	10 (3)	2 3/16 (55)	87 (129)
(*)-08-240	(*)N-08-240	8 (203)	20 (6)	2 3/16 (55)	87 (129)

Cable Channel Fittings

All fittings are of mitered construction with 12" (305) radius.

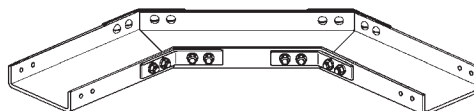

Horizontal	3" series	4" series	6" series	8" series
90°	(*)N-03-90HB12	(*)N-04-90HB12	(*)N-06-90HB12	(*)N-08-90HB12
45°	(*)N-03-45HB12	(*)N-04-45HB12	(*)N-06-45HB12	(*)N-08-45HB12

One pair of splice plates included.

Vertical	3" series	4" series	6" series	8" series
90°	(*)N-03-90V*12	(*)N-04-90V*12	(*)N-06-90V*12	(*)N-08-90V*12
45°	(*)N-03-45V*12	(*)N-04-45V*12	(*)N-06-45V*12	(*)N-08-45V*12

One pair of splice plates included.

(*) Insert material type

- FCC for Polyester Resin - available for all widths
- FCCV for Vinyl Ester Resin - available for all widths

● Green = Fastest shipped items ● Black = Normal lead-time items ● Red = Normally long lead-time items

Dimensions shown in parentheses are in millimeters, unless otherwise specified.

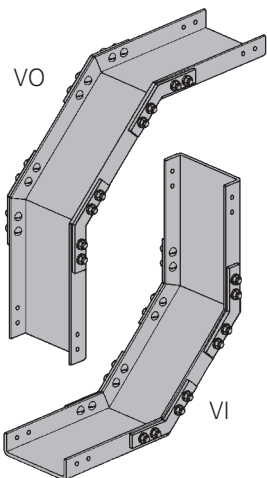

Fiberglass - Cable Channel Fittings & Accessories

Horizontal Tees

- Two pair of splice plates included.

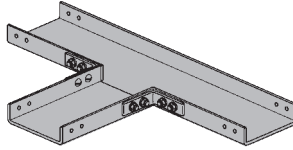

Catalog No.	Width in. (mm)
FCC(*)N-03-HT12	3 (76)
FCC(*)N-04-HT12	4 (101)
FCC(*)N-06-HT12	6 (152)
FCC(*)N-08-HT12	8 (203)

(*) See page fitting material selection bottom of page M-31

All fittings are of mitered construction with 12" (305) radius.

Horizontal Crosses

- Three pair of splice plates included.

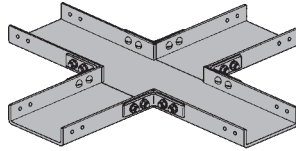

Catalog No.	Width in. (mm)
FCC(*)N-03-HX12	3 (76)
FCC(*)N-04-HX12	4 (101)
FCC(*)N-06-HX12	6 (152)
FCC(*)N-08-HX12	8 (203)

(*) See page fitting material selection bottom of page M-31

All fittings are of mitered construction with 12" (305) radius.

Splice Plates

- Sold in pairs - included with tray sections.
- Uses 1/4"-20 316SS hardware

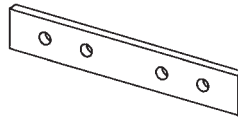

Catalog No.
9(Δ)-1001SS6

Expansion Splice Plates

- Sold in pairs
- Uses 1/4"-20 316SS hardware

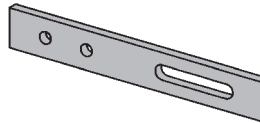

Catalog No.
9(Δ)-1013SS6

Horizontal 90° Splice Plates

- Sold in pairs
- Uses 1/4"-20 316SS hardware

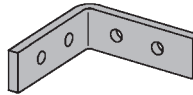

Catalog No.
9(Δ)-1901HSS6

Horizontal 45° Splice Plates

- Sold in pairs
- Uses 1/4"-20 316SS hardware

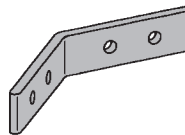

Catalog No.
9(Δ)-1451HSS6

Horizontal 30° Splice Plates

- Sold in pairs
- Uses 1/4"-20 316SS hardware

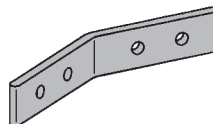

Catalog No.
9(Δ)-1301HSS6

Splice plates included with cable channel sections.
Hardware for splice plates is 1/4"-20 (316SS).

(Δ) See page M-27 for material selection

Dimensions shown in parentheses are in millimeters, unless otherwise specified.

Fiberglass - Cable Channel Accessories

Horizontal 90° Splice Plates

- Sold in pairs
- Uses 1/4"-20 316SS hardware

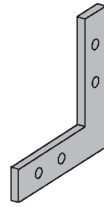

Catalog No.

9(Δ)-1901VSS6

Horizontal 45° Splice Plates

- Sold in pairs
- Uses 1/4"-20 316SS hardware

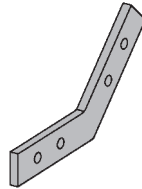

Catalog No.

9(Δ)-1451VSS6

Horizontal 30° Splice Plates

- Sold in pairs
- Uses 1/4"-20 316SS hardware

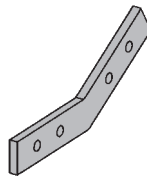

Catalog No.

9(Δ)-1301VSS6

Horizontal Adjustable Splice Plates

- Sold per piece
- Uses 3/8"-16 316SS hardware

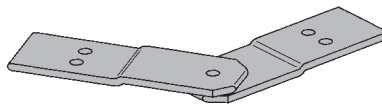

Catalog No.

9(Δ)-1023SS6

Vertical Adjustable Splice Plates

- Sold per piece
- Uses 3/8"-16 316SS hardware
- Body made from 316 stainless steel
- Used for all material finishes

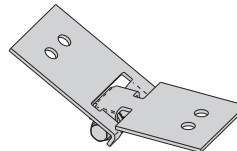

Catalog No.

9F-1033SS6

Expansion Guide Clamp

- Sold per clamp
- Order 1/2" hardware separately

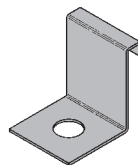

Catalog No.	Width in. (mm)
● 9SS6-1248-3	3 (76)
● 9SS6-1248-4	4 (101)
● 9SS6-1248-6	6 (152)
● 9SS6-1248-8	8 (203)

Hold-Down Clamp

- Sold per clamp
- Order 1/2" hardware separately

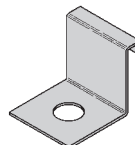

Catalog No.	Width in. (mm)
● 9SS6-1247-3	3 (76)
● 9SS6-1247-4	4 (101)
● 9SS6-1247-6	6 (152)
● 9SS6-1247-8	8 (203)

● Green = Fastest shipped items ● Black = Normal lead-time items ● Red = Normally long lead-time items

(Δ) See page M-27 for material selection

Dimensions shown in parentheses are in millimeters, unless otherwise specified.

Marine Rung Cable Tray/Fiberglass

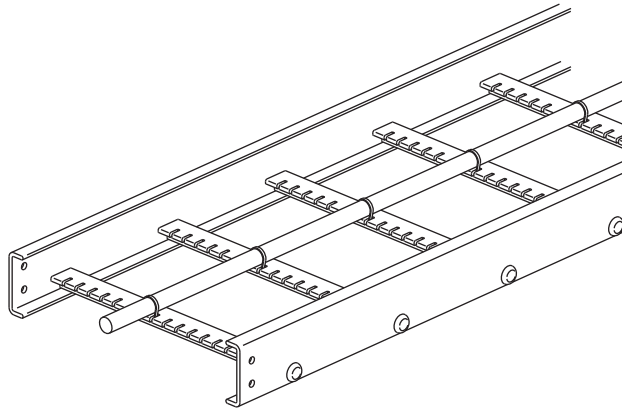

Features:

- For Coast Guard Requirements
 - Allows stainless steel banding of cables
 - $\frac{5}{32}$ " (15.9) slots 1" (25.4) on centers
 - Accommodates up to $\frac{5}{8}$ " (15.9) banding
- Has applications on land
 - Vertical installation
 - Any location where extra cable positioning is required
- Designed for Eaton's B-Line series Fiberglass Cable Trays
- Part Number Indication
 - Add MR after rung spacing
 - Example: 46F09MR-36-240

Rung design provides:

- 2" (50.8) cable support surface
- Both mechanical and adhesive rung to side rail connection

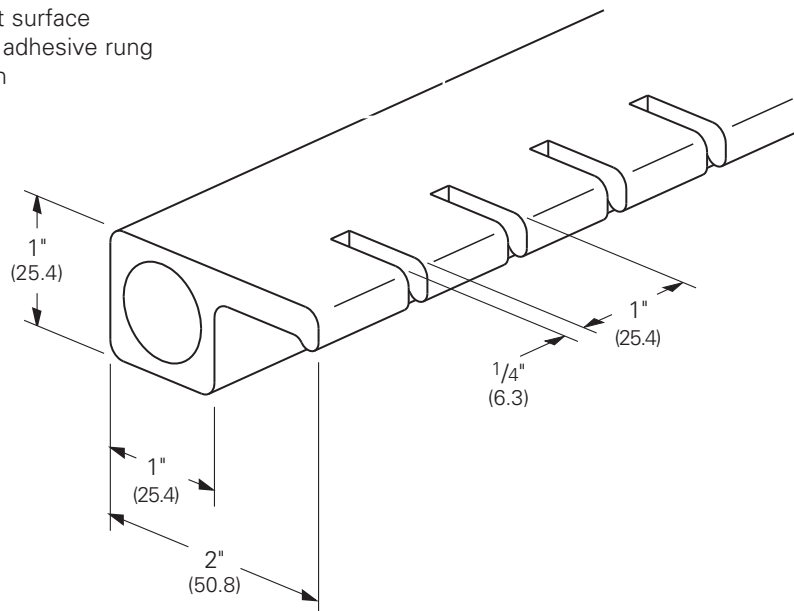

Dimensions shown in parentheses are in millimeters, unless otherwise specified.

Trefoil Cable Cleat with LSF Pad

1. Recommended for installations where the highest levels of short circuit withstand are required.
2. Short circuit current tested in accordance with BS EN/IEC 61914 standard.
3. Available for single and trefoil cable applications.
4. LSF-pad incorporates an integral low smoke, low fume, zero halogen pad.
5. Hardware to attach cleat to rung attachment bracket is included with cleat. Bracket must be ordered separately.

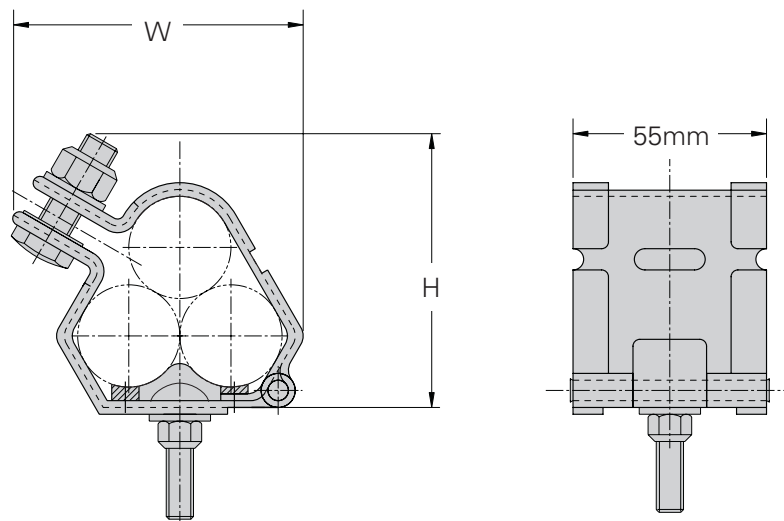

BS EN/IEC 61914 (Cable Cleats for Electric Installations) Classification

Cleat Type	Composite
Resistance to Electromechanical Force	130 kA peak / 50 kA RMS 600 mm spacing
Lateral Load Test	3.439 kg average
Axial Load Test	Pass
Operating Temperature Range	-40°C to +60°C
Impact Resistance	Very Heavy
Needle Flame Test	30 seconds

Technical Specifications

Frame	50mm x 2mm Marine grade, Non-magnetic 316L
Closure Hardware	Captive 316 Stainless Steel M8 or M10 (M12 available) bolt and nylon-lock nut (Optional Hex Flange Lock Nut available)
Integral Pad	Low Smoke, Low Fume, Zero Halogen
Tools Required	Impact Wrench
Mounting Bolt	Provided with Cable Cleat

Part No.	Cable Range (mm)		Dimensions (mm)	
	Min. Dia.	Max. Dia.	H	W
9SS6-CCT1323	13	22	74	66
9SS6-CCT2125	21	25	77	70
9SS6-CCT2329	23	29	81	78
9SS6-CCT2531	25	31	84	81
9SS6-CCT2733	27	33	86	83
9SS6-CCT2935	29	35	90	89
9SS6-CCT3238	32	38	94	95
9SS6-CCT3541	35	41.5	98	100
9SS6-CCT3844	38	44.5	101	104
9SS6-CCT4248	42	48	105	111
9SS6-CCT4551	45	51	109	117
9SS6-CCT4753	47	53	111	120
9SS6-CCT4955	49	55	114	124
9SS6-CCT5157	51	57	116	127
9SS6-CCT5359	53	59	119	133
9SS6-CCT5561	55	61	127	137
9SS6-CCT5763	57	63	126	140
9SS6-CCT5965	59	65	128	144
9SS6-CCT6167	61	67	132	147
9SS6-CCT6369	63	69	136	150

Part No.	Cable Range (mm)		Dimensions (mm)	
	Min. Dia.	Max. Dia.	H	W
9SS6-CCT6571	65	71	140	153
9SS6-CCT6773	67	73	143	156
9SS6-CCT6975	69	75	147	160
9SS6-CCT7177	71	77	151	163
9SS6-CCT7379	73	79	154	166
9SS6-CCT7581	75	81	158	169
9SS6-CCT7783	77	83	161	173
9SS6-CCT7985	79	85	164	176
9SS6-CCT8187	81	87	169	179
9SS6-CCT8389	83	89	173	182
9SS6-CCT8692	86	92	177	187
9SS6-CCT8896	88	96	181	192
9SS6-CCT9199	91	99	185	196
9SS6-CCT96103	96	103	190	201
9SS6-CCT99107	99	107	194	202
9SS6-CCT103111	103	111	199	204
9SS6-CCT107115	107	115	203	208
9SS6-CCT111119	111	119	208	213
9SS6-CCT115123	115	123	213	217
9SS6-CCT119128	119	128	217	221

Single Cable Cleat with LSF Pad

1. Recommended for installations where the highest levels of short circuit withstand are required.
2. Short circuit current tested in accordance with BS EN/IEC 61914 standard.
3. Available for single and trefoil cable applications.
4. LSF-pad incorporates an integral low smoke, low fume, zero halogen pad.
5. Hardware to attach cleat to rung attachment bracket is included with cleat. Bracket must be ordered separately.

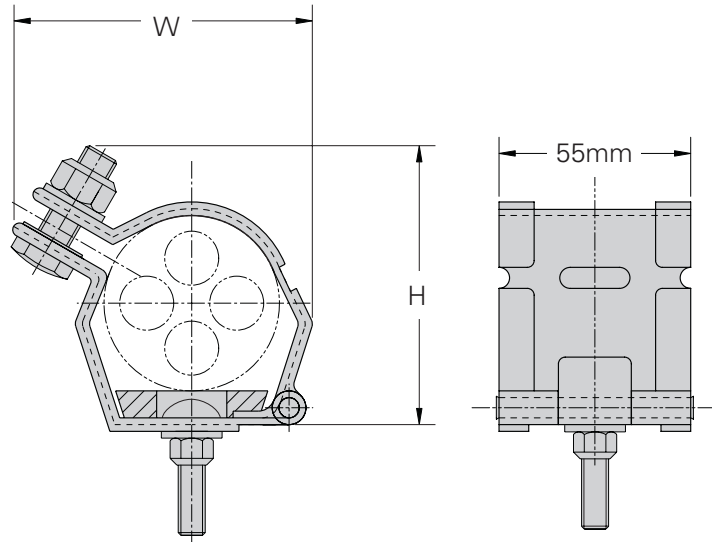
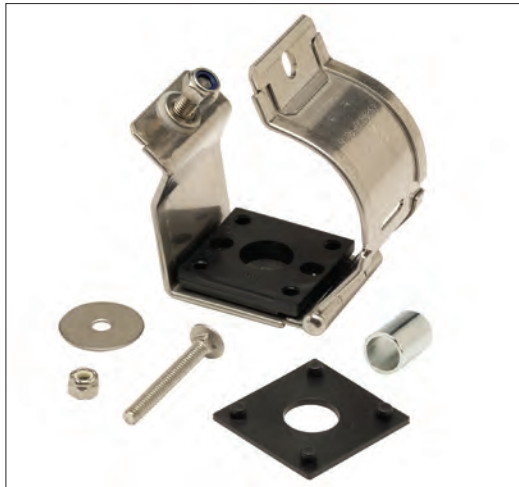

BS EN/IEC 61914 (Cable Cleats for Electric Installations) Classification

Cleat Type	Composite
Resistance to Electromechanical Force	130 kA peak / 50 kA RMS 600 mm spacing
Lateral Load Test	3.439 kg average
Axial Load Test	Pass
Operating Temperature Range	-40°C to +60°C
Impact Resistance	Very Heavy
Needle Flame Test	30 seconds

Technical Specifications

Frame	50mm x 2mm Marine grade, Non-magnetic 316L
Closure Hardware	Captive 316 Stainless Steel M8 or M10 (M12 available) bolt and nylon-lock nut (Optional Hex Flange Lock Nut available)
Integral Pad	Low Smoke, Low Fume, Zero Halogen
Tools Required	Impact Wrench
Mounting Bolt	Provided with Cable Cleat

Part No.	Cable Range (mm)		Dimensions (mm)	
	Min. Dia.	Max. Dia.	H	W
9SS6-CCS2832	28	32	61	55
9SS6-CCS3034	30	34	63	57
9SS6-CCS3236	32	36	65	59
9SS6-CCS3438	34	38	67	61
9SS6-CCS3640	36	40	71	63
9SS6-CCS3842	38	42	69	65
9SS6-CCS4044	40	44	71	67
9SS6-CCS4246	42	46	72	69
9SS6-CCS4448	44	48	74	71
9SS6-CCS4650	46	50	75	73
9SS6-CCS4852	48	52	77	75
9SS6-CCS5054	50	54	79	77
9SS6-CCS5256	52	56	80	79
9SS6-CCS5458	54	58	81	81
9SS6-CCS5660	56	60	83	83
9SS6-CCS5862	58	62	85	85
9SS6-CCS6064	60	64	86	87
9SS6-CCS6266	62	66	88	89
9SS6-CCS6468	64	68	90	91
9SS6-CCS6670	66	70	91	93

Part No.	Cable Range (mm)		Dimensions (mm)	
	Min. Dia.	Max. Dia.	H	W
9SS6-CCS6872	68	72	93	95
9SS6-CCS7074	70	74	95	97
9SS6-CCS7276	72	76	97	99
9SS6-CCS7478	74	78	99	101
9SS6-CCS7680	76	80	101	103
9SS6-CCS7682	76	82	103	105
9SS6-CCS8084	80	84	105	107
9SS6-CCS8286	82	86	107	109
9SS6-CCS8488	84	88	109	111
9SS6-CCS8690	86	90	110	113
9SS6-CCS88192	88	192	113	117
9SS6-CCS9094	90	94	116	120
9SS6-CCS9296	92	96	126	127
9SS6-CCS94106	94	106	135	133
9SS6-CCS100112	100	112	140	139
9SS6-CCS106118	106	118	145	145
9SS6-CCS112124	112	124	153	155
9SS6-CCS118130	118	130	162	165
9SS6-CCS127139	127	139	161	167
9SS6-CCS132144	132	144	165	173
9SS6-CCS138150	138	150	170	179

Step 1: Know Your Cables

- What type of cable is being used?
 - Single or Multi-conductor
- What is the outside diameter of the cable(s)?
- What is the cable arrangement (single conductor cables only)?
 - Flat or Trefoil
- If a ground wire will be installed within the cleat, you will need the ground wire outside diameter.

Step 2: Know Your System

- What is the available short circuit current (RMS or i_p (peak))?
- What type of B-Line cable tray is installed?

Step 3: Select Your Cable Cleats

- See Pages N-2 & N-3

Step 4: Select Your Mounting Bracket

Mounting brackets are used to attach cable cleats to the rungs of the ladder type cable trays. Your tray type will determine the mounting bracket used.

B-Line Tray Types	Mounting Bracket
Aluminum welded rung trays with standard rungs. Steel Series 2, 3, 4 or 5, trays with standard rungs Fiberglass trays with standard rungs	9SS6-CCB-C
Steel Series 1 trays with standard rungs	9SS6-CCB-A
Steel trays with strut rungs Aluminum trays with "Marine Rungs"	9SS6-CCB-B

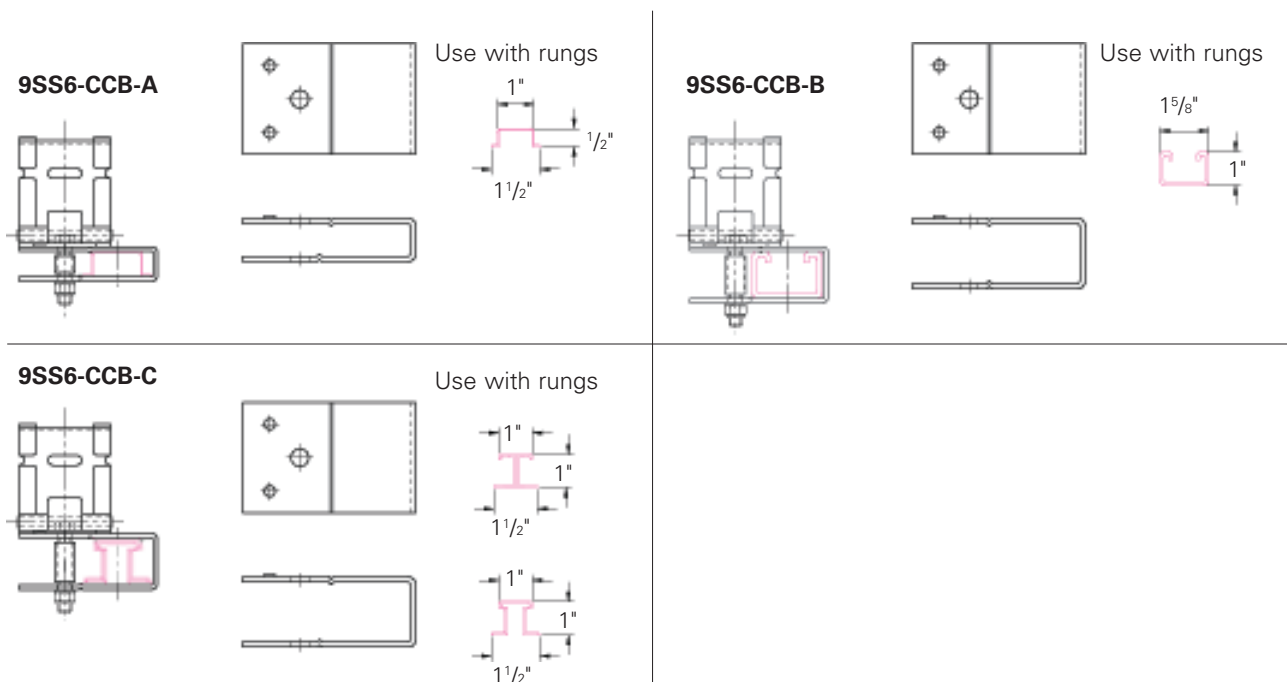

Cable Cleats

Step 5: Determine Cleat Spacing for Installation

Your cable diameter is equal to the spacing between conductor centers shown below. Find your cable diameter at the top of the table and look down at the column below it. Find the value equal to or greater than the available short circuit for your system.

Single Conductor Short Circuit Withstand Table

Max. Cable Cleat Spacing (A)		Spacing Between Conductor Centers (mm)											
		23	25	27	29	31	33	35	37	39	41	43	45
mm	In.	i_p peak (kA)											
225	9	179	187	194	203	209	216	220	229	234	240	246	250
300	12	155	163	168	174	181	187	192	198	203	209	214	215
450	18	128	133	137	144	148	152	157	161	165	170	174	178
600	24	110	115	119	124	128	132	135	139	143	148	150	153
675	27	104	108	113	117	121	124	128	132	135	139	143	147
900	36	89	93	97	102	104	108	110	115	117	121	124	127

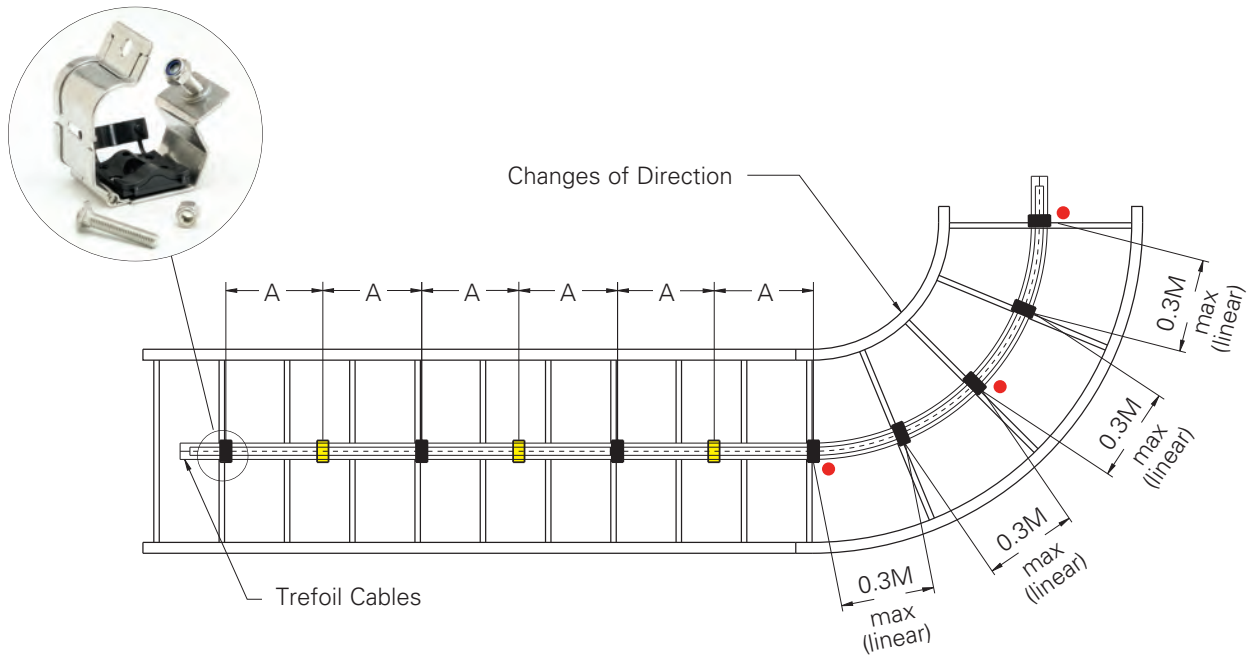

IMPORTANT: Recommended Installation Procedures

It is important that the cleats are installed properly to secure your cables:

- It is not necessary for every cleat to be attached to the tray. Every other cleat (■) must be attached to the tray system to mount cable in tray. Unattached cleats (□) provide additional restraint to keep cables bundled.
- The bend radius should be 8 to 12 times the cable diameter.
- Cleats should always be installed at the beginning, middle and end of a bend (●), and at no time should the distance between cleats on a bend be more than 0.3M center to center.

3M™† Fire Barrier Self-Locking Pillows

Features & Benefits

- Extremely easy to install - saves time and labor
- Easy removal and fully reusable - with no blocking or fusing of materials
- No cutting required, no left over debris
- Up to three-hour UL Listed F-Rating
- UL Listed systems up to 540 sq. in. opening
- Passes hose stream test without cumbersome wire mesh
- Smoke seal tested and listed
- Listed for blank or filled openings in gypsum wallboard or concrete
- Available in three (3) sizes
- One (1) or two (2) cable trays per opening

This product will intumesce and lock tightly into place eliminating the prep work of cutting or leaving any messy debris. The resulting barrier retards the transmission of smoke, fire, and toxic gases from spreading between adjacent rooms and floors for the rated time period.



Catalog Number	Type	Pillow Size	
		in.	(mm)
FSP-SLP-S	Small	2" x 4" x 9"	(51 x 101 x 228)
FSP-SLP-M	Medium	2" x 6" x 9"	(51 x 152 x 228)
FSP-SLP-L	Large	3" x 6" x 9"	(76 x 152 x 228)

The following charts give the number of 3M pillows needed to completely firestop an opening that cable tray passes through.* Two (2) sticks of moldable putty (part number FSP-MPS) are also needed for each opening.

Width	Height			
	1.5	2	4	6
2	--	4	--	--
4	4	5	7	--
6	5	6	8	--
8	7	7	10	13
12	8	10	13	17
16	--	12	17	21
18	--	13	18	24
20	--	15	20	26
24	--	17	24	30
30	--	21	29	--
36	--	22	--	--

Width	Height			
	4	5	6	7
6	8	9	10	11
9	11	12	14	15
12	13	15	17	19
18	18	21	24	26
24	24	27	30	34
30	29	33	37	41
36	34	39	44	49
42	39	45	51	56
48	45	51	57	64

Width	Height		
	3	4	6
3	5	5	7
6	7	8	10
9	9	11	14
12	11	13	17
18	16	18	24
24	20	24	30

Width	Height		
	4	5	6
6	8	9	10
9	11	12	14
12	13	15	17
18	18	21	24
24	24	27	30
30	29	33	37
36	34	39	44

UL Listed Systems

Concrete Wall - C-AJ-4056 3 HR F-Rating, 3/4 HR T-Rating

Gypsum Wall - W-L-4037 1 HR and 2 HR F-Ratings, 0 HR and 1/2 HR T-Ratings

For tray larger than 4" x 24", or a tray style other than ladder tray call 1-800-328-1687 then option 8 to obtain a free engineering judgement letter.

* Number of pillows refers to 3M's medium self-locking pillows (part number FSP-SLP-M) and are based on an opening that is 1.5" larger than the tray on all sides.

Example: For a 4" x 12" tray the recommended opening would be 7" x 15".

† 3M™ is a registered trademark of the 3M Company

3M™† Fire Barrier Moldable Putty+



Features & Benefits

- Pliable. Easy to mold into any shape
- Adheres. Sticks well to most surfaces but not to the applicator's hands
- Conformable. Pads easily conform and adhere to a wide variety of metallic and non-metallic electrical outlet boxes
- UL Listed. Wide range of UL Listed systems
- Ages Well. Excellent aging properties

3M Fire Barrier Moldable Putty+ is a one-part, halogen-free product designed to firestop electrical outlet boxes and a wide variety of through-penetrations including cable, conduit, insulated pipe and metal pipe, which penetrate fire-rated construction.

Catalog Number	Type	Size	
		in.	(mm)
FSP-MPP-4x8	Small Pad	4" x 8"	(101 x 203)
FSP-MPP-7x7	Medium Pad	7" x 7"	(178 x 178)
FSP-MPP-9x9	Large Pad	9 1/2" x 9 1/2"	(241 x 241)

3M™† Fire Barrier CS-195+ Composite Sheets

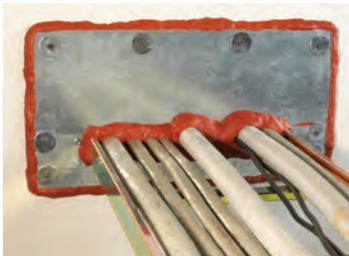

Features & Benefits

- Ideal for fire-stopping blank openings and through-penetrations of multiple cable, pipe ducts, buss ducts and cable trays
- Intumescent
- Lightweight and easy to handle - just cut and form to fit
- Easy to install using common trade tools
- Easy to fasten - bolt punch or drill through and use self-tapping screws or anchor bolts
- Bottom-of-floor applications available
- No mixing or damming required
- Re-enterable
- Documented aging properties

This organic/inorganic elastomeric sheet is bonded on one side to a layer of 28-gauge galvanized steel. The other side is reinforced with a steel-wire mesh and covered with aluminum foil.

Catalog Number	Type	Size	
		in.	(mm)
FSP-CS-16x28	Sheet	16" x 28"	(406 x 711)
FSP-CS-28x52	Sheet	28" x 52"	(711 x 1320)
FSP-CS-36x24	Sheet	36" x 24"	(914 x 609)
FSP-CS-36x36	Sheet	36" x 36"	(914 x 914)
FSP-CS-36x41	Sheet	36" x 41"	(914 x 1041)

† 3M™ is a registered trademark of the 3M Company

3M™† Fire Barrier Quick Pass Devices



Features & Benefits

- Hinged for existing cables
- Stackable for multiple penetrations
- Optional mounting brackets - single or triplex
- Install before or after gypsum wall assembly
- Easily identified red color
- Quick to pass cables
- JCAHO and NFPA Life Safety Code 101 compliant
- UL Classified 1, 2 and 3 hour fire (F) and temperature (T) rating
- UL Classified L rating, Hot and Cold Smoke Seal
- ULC

The Quick Pass Device makes installation and retrofitting a snap. Simply follow the instructions located on the product. Use this product in new construction or update your fire protection in a renovation - the optional mounting bracket opens easily allowing retrofit installations. As your needs change, reuse the device for additional cables and wiring.

Catalog Number	Type	Size
FSP-QPS-2	Square Device	2 1/2" (63mm) Square
FSP-QPS-2BRK	Optional Mounting Bracket for FSP-QPS-2	--
FSP-QPS-4	Square Device	4" (101mm) Square
FSP-QPS-4BRK	Optional Mounting Bracket for FSP-QPS-4	--
FSP-QPR-4	Square Device	4" (101mm) Round
FSP-QPR-4BRK	Optional Mounting Bracket for FSP-QPR-4	--

† 3M™ is a registered trademark of the 3M Company

Firestop

3M™† Fire Barrier CP-25WB+ Caulk



Features & Benefits

- Water based - easy cleanup and routine disposal with no special handling
- One-part system - no mixing or measuring required
- Intumescent and endothermic
- No-sag, non-halogen formula
- Fast drying - tack-free in approximately 10 to 15 minutes
- Water-resistant seal
- Paintable
- Documented aging properties

Our premium, intumescent latex/water-based caulk. CP 25WB Caulk can be installed with a standard caulking gun



Catalog Number	Type
FSP-BC-25	10.1 ounce Tube

3M™† Fire Barrier IC-15WB+ Caulk



Features & Benefits

- Cost effective
- UL tested
- Distinctive yellow color makes inspections easier
- For use as a one-part fire, smoke, noxious gas and water sealant

This is an affordable firestop caulk that helps you stay on budget. Its unique intumescent property allows IC 15WB Caulk to effectively contain fire and smoke at its origin. IC 15WB Caulk can be installed with a standard caulking gun



Catalog Number	Type
FSP-BC-15	10.1 ounce Tube

3M™ Aluminum Foil Tape 425



Features & Benefits

- 3-mil aluminum foil
- Acrylic adhesive performs in high temperatures

Designed to seal the cut edges of 3M™ Interam Mats to complete the total encapsulation.

Catalog Number	Type
FSP-AT-425	4" (101mm) x 180' (27.5m) Roll

† 3M™ is a registered trademark of the 3M Company

3M™† Interam™† E-5 Series Mat

Features & Benefits

- Provides up to three (3) hours of electrical circuit protection
- Made of a combination of organic/inorganic materials
- Outdoor durable
- Endothermic
- Available with a stainless-steel or aluminum backing
- Outstanding performance in high-intensity fires
- Easy to install in new applications or directly over existing fire protection

Blocks heat penetration by chemically absorbing heat energy to protect structural steel and cable trays.



Catalog Number	Type
FSP-EMAT	24 1/2" (622mm) x 20' (6.09m) Roll

† 3M™ and Interam™ are registered trademarks of the 3M Company

Wall Sleeve Kits & Accessories



'CT' Type Wall Sleeve
Sleeve is 20" long

'U' Type Wall Sleeve
WS (Wall Sleeve) shown
Sleeve is 20" long

- "CT" Type tray includes two (2) pair 9ZN-800* splice plates with 3/8" zinc plated hardware.
 - "U" Type tray does not include splices. Example uses include Wire Basket or Half-Rack.
- * Insert tray height.



Classified by Underwriters Laboratories, Inc. as to its suitability as an equipment grounding conductor only. 556E

Wall Sleeve Part Numbering

Example: **9P - xxx - CT - 4 - 12**

Finish	Type	Tray Type	Tray Height	Tray Width
P = Pregalvanized	WS = Wall Sleeve	CT = Cable Tray † U = Universal	4 5 6 7	06 = 6" 09 = 9" 12 = 12" 18 = 18" 24 = 24" 30 = 30" 36 = 36"

† 'CT' Type furnished with steel splice plates (9ZN-800*). For aluminum cable trays use the furnished splice plates and field drill 13/32" diameter holes in the aluminum side rails.

These options are in addition to the Standard Ladder Rungs and Cable Trays.

Marine Rung (Available in Aluminum, HDGAF Steel and Stainless Steel)

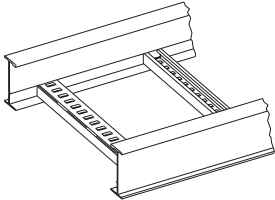

(Aluminum Shown)

- Designed for Series 1 and Series 2-5 systems.
 - Special rung design to accommodate stainless steel banding of cables (U.S. Coast Guard requirement) with .438" x .720" slots.
 - Has applications on land, vertical installation, any location where extra cable positioning/attachment is required.
 - Strut orientation may be channel opening up, channel opening down, or alternating - standard is alternating unless specified otherwise.
 - New design provides combination of strut fastening and marine rung fastening.
- Examples: 46A12MR-36-288 or 464G12MR-36-288
- "MR" Strut rung spaces 12" apart with channel opening down (Note: replace "DN" with "UP" for channel opening up.)

Special Rung Spacings: 4" & 18" rung spacing available upon request.

Solid Bottom

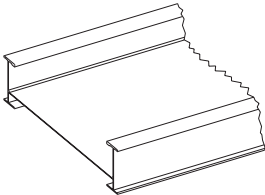

- Solid flat sheet welded into the Cable Tray above the rungs.
- Standard rung spacing is 12 inches.
- The flat sheet may be installed over B54 rungs "slot down".

Examples: 24ASB-36-144
Flat sheet bottom over standard rung on 12" spacing.
24ASBB54-36-144
Flat sheet bottom over B54 strut rung slot down on 12" spacing.

9A-6006 and 9A-6007 Aluminum Mid-Span Splice

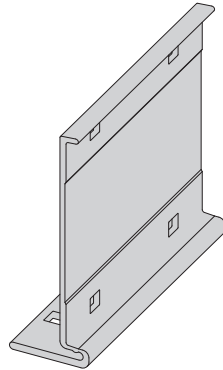

Features

- Standard for H46A, H47A and 57A straight sections.
- Allows random splice location.
- Six bolt design furnished with standard 1/2" Stainless Steel Type 316 hardware.
- Furnished in pairs.
- Available on ladder bottoms only. 09" and 12" rung spacing.

Tray	
Series	Catalog No.
H46A	9A-6006
H47A	9A-6007
57A	9A-6007

Cable Tray

H46A

Tested to:

- 167 lbs/ft (safety factor 1.5)
- 125 lbs/ft (safety factor 2.0)
- 20 ft. simple beam test
12" rung spacing - 36" wide

H47A

Tested to:

- 149 lbs/ft (safety factor 1.5)
- 112 lbs/ft (safety factor 2.0)
- 20 ft. simple beam test
12" rung spacing - 36" wide

Splice

9A-6006

Tested to:

- 135 lbs/ft (safety factor 1.5)
- 101 lbs/ft (safety factor 2.0)
- 20 ft. simple beam test
mid-span splice

9A-6007

Tested to:

- 143 lbs/ft (safety factor 1.5)
- 107 lbs/ft (safety factor 2.0)
- 20 ft. simple beam test
mid-span splice

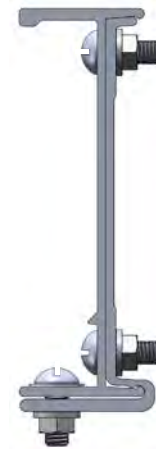

Options: The 9A-6006 and 9A-6007 splice is also available with B-Line series 46A and 47A series cable tray systems.

- Available on ladder bottoms only (09" and 12" rung spacing).
- Available on 240" (20') or longer span straight sections.
- To order add MS* to part number: Ex. 46AMS09-24-288.
- For standard 6A or 7A fittings with H46A or H47A systems an additional pair of standard splice plates is required (9A-1006 or 9A-1007).

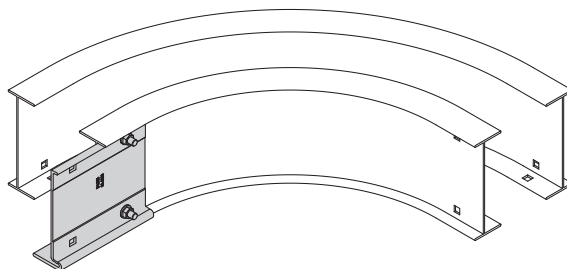

One pair 9A-6006 or 9A-6007 included.

H6A and H7A Fittings

- Ladder bottom only (09" RS).
- Incorporates the 9A-6006 or 9A-6007 splice.
- Example: H6A-12-90HB24 or H7A-12-90HB24

* MS designates additional hole punches in side rail to accept mid-span splices.

Heavy Duty Expansion Splice Plates

- 9A-6016 and 9A-6017 (aluminum)
- 9G-6016 and 9G-6017 (HDG steel)
- 9SS6-6016 (stainless steel)

The Heavy Duty Expansion Splice Plate is engineered to eliminate the NEMA recommended additional supports at each expansion joint where expansion splice plates are utilized. Expansion splices are common in long-run outdoor applications, where temperature variations result in thermal expansion and contraction of the cable tray system. The installer using the traditional expansion splice would be required to install two supports, one on either side of the expansion splice. By utilizing the Heavy Duty Expansion Splice Plate, no additional supports are required when the splice is placed at quarter span.

- NEMA VE 2 Compliant.
- Lowest total cost of installation solution.
- “Wrap around” design that supports the side rail on the bottom of each tray section.
- Aluminum HD Expansion Splice includes viewing windows to correctly set the thermal expansion gap. See Figure 4.13B on MAN-39 of the cable tray catalog .
- Available in lightweight, marine-grade 6063-T6 aluminum material, hot dip galvanized steel, and stainless steel 316 for easy installation in a variety of applications.
- Visit Eaton.com/cabletray for detailed installation instructions.
- Splice plate hardware included.
- Furnished in pairs.
- Cannot be used with solid bottom styles of cable tray.

Heavy Duty Expansion Splice Plates are currently available with aluminum (H46A, H47A & 57A), steel (464, 476 & 574) and stainless steel (464) tray systems. These tray systems are heavy duty ladders that are ideal for long-span outdoor applications.

Patented: Patent No. US8459604 B2

Options: The 9A-6006 and 9A-6007 splice is also available with B-Line series 46A and 47A series cable tray systems

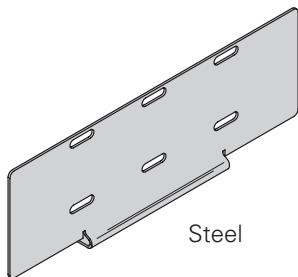

Steel

Steel	
Tray Series	Catalog No.
464	9G-6016 or 9SS6-6016
476	9G-6017
574	9G-6017

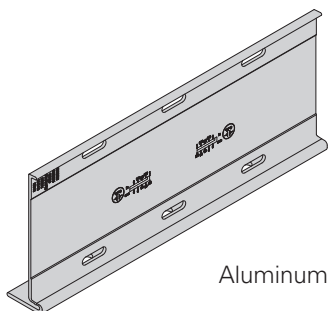

Aluminum

Aluminum	
Tray Series	Catalog No.
46A *	9A-6016
H46A	9A-6016
H47A	9A-6017
57A	9A-6017

* Additional field drilling is required

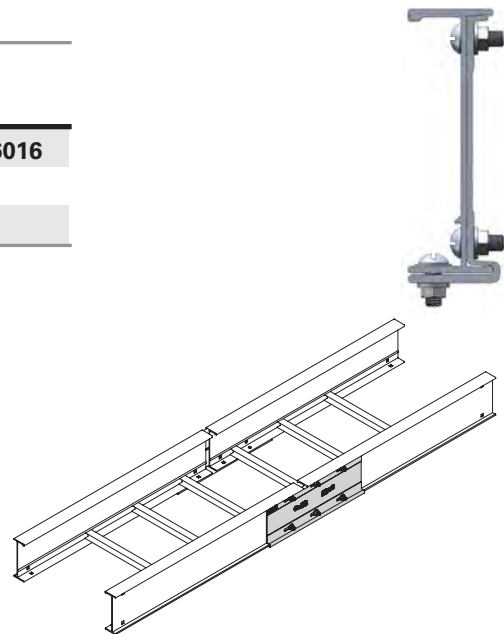

Aluminum heavy-duty expansion splice plates shown.

Note: 24" (609mm) bonding jumper (**99-1620-24**) available.

Special Purpose 2 to 3 Pitch Peaked Covers

These covers are not available for Series 1 system or in steel with a pre-galvanized finish.

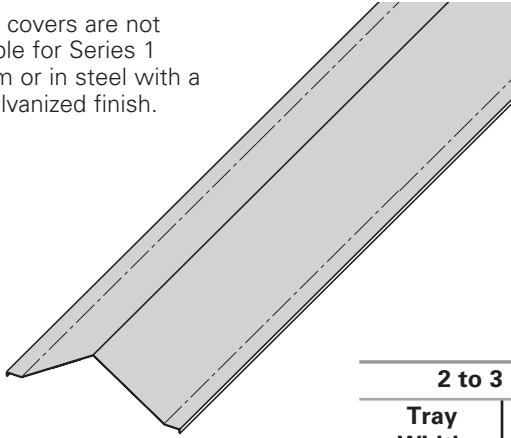

Features

- 33° slope to shed precipitants.
- Heavy construction - made for the industrial environment.
- Available in aluminum and steel; hot dip galvanized after fabrication (HDGAF ASTM A-123), 304 stainless and 316 stainless.
- Available in flanged design only.
- Fittings are in multiple piece welded construction.
- Expanding/Reducing HT and HX covers are not available.

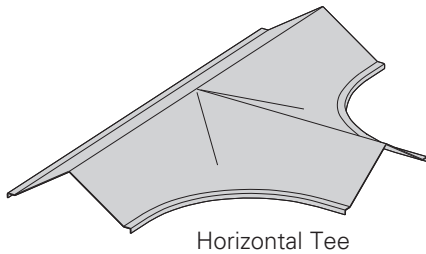

2 to 3 Pitch	
Tray Width	Peak Height
6"	2"
9"	3"
12"	4"
18"	6"
24"	8"
30"	10"
36"	12"

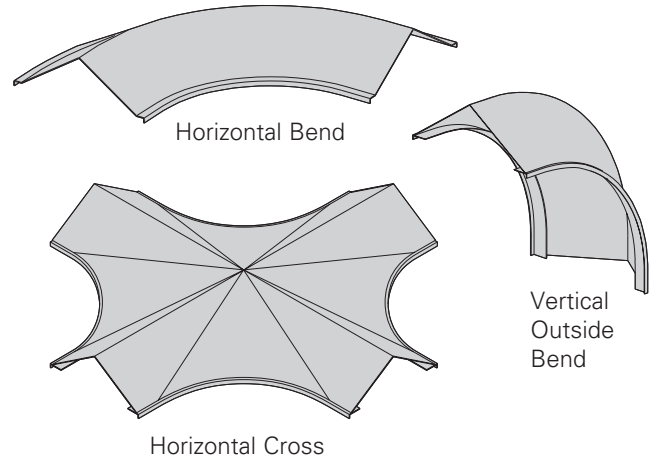

Catalog Number Selector

Example: **83 7 A 80 - 24 - 144**

Cover Type	Detail	Material	Material Thickness	Tray Width	Item Description
● 83 = 2 to 3 Pitch Peaked	7 = Flanged Aluminum 2 = Flanged Steel (248, 258, 268 straight sections & fittings) 3 = Flanged Steel (All straight sections except 248, 258, 268)	A = Aluminum G = HDGAF ASTM A-123 SS4 = 304 Stainless Steel SS6 = 316 Stainless Steel	80 = .080 Aluminum straight section 125 = .125 Aluminum fittings 16 = 16 Ga. Steel straight sections. 18 = 16 Ga. Steel fittings.	06 = 6" 09 = 9" 12 = 12" 18 = 18" 24 = 24" 30 = 30" 36 = 36"	144 = 12 ft. (3.66 m) 120 = 10 ft. (3.05 m) 72 = 6 ft. (1.83 m) 60 = 5 ft. (1.52 m)

2 to 3 Pitch Cover Clamp

• Recommended for outdoor service.

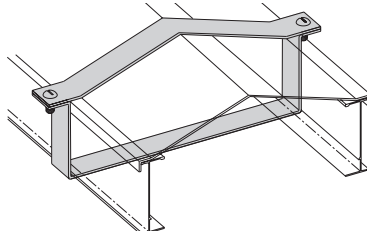

Side Rail Height in. (mm)	Catalog No. Aluminum	Catalog No. Steel	Catalog No. Stainless Steel
4 (101)	● 9A-(‡)-9P44	● 9G-(‡)-9P44	● 9**-(‡)-9P44
5 (127)	● 9A-(‡)-9P54	● 9G-(‡)-9P54	● 9**-(‡)-9P54
6 (152)	● 9A-(‡)-9P64	● 9G-(‡)-9P64	● 9**-(‡)-9P64
7 (178)	● 9A-(‡)-9P74	● 9G-(‡)-9P74	● 9**-(‡)-9P74

(‡) Insert tray width

(**) Insert SS4 or SS6

● Green = Fastest shipped items ● Black = Normal lead-time items ● Red = Normally long lead-time items

Wiring methods permitted in cable tray per the 2011 NEC®

1. Armored cable (Article 320)
2. Electrical metallic tubing (Article 358)
3. Electrical nonmetallic tubing (Article 362)
4. Fire alarm cables (Article 760)
5. Flexible metal conduit (Article 348)
6. Flexible metallic tubing (Article 360)
7. Instrumentation tray cable (Article 727)
8. Intermediate metal conduit (Article 342)
9. Liquidtight flexible metal conduit (Article 350)
10. Liquidtight flexible nonmetallic conduit (Article 356)
11. Metal-clad cable (Article 330)
12. Mineral-insulated, metal-sheathed cable (Article 332)
13. Multiconductor service-entrance cable (Article 338)
14. Multiconductor underground feeder and branch-circuit cable (Article 340)
15. Multipurpose and communications cables (Article 800)
16. Nonmetallic-sheathed cable (Article 334)
17. Power and control tray cable (Article 336)
18. Power-limited tray cable (Section 725.61(C) and 725.71(E))
19. Optical fiber cables (Article 770)
20. Other factory-assembled, multiconductor control, signal, or power cables that are specifically approved for installation in cable trays
21. Rigid metal conduit (Article 344)
22. Rigid nonmetallic conduit (Article 352)

Appendix - Reference Material - Formulas

Formulas

• Allowable load: $w = \frac{F96Sx}{L^2}$

• Deflection: $\Delta = \frac{5wL^3}{384EIx}$
 $= \frac{5wL^4}{4608EIx}$

• Stress: $F = \frac{wL^2}{96Sx}$

• Deflection Multiplier (K) = $\frac{\text{Deflection}}{w}$
 $= \frac{5L^4}{4608EIx}$

• Max. Working Load = $\frac{\text{Max. deflection}}{\text{Deflection Multiplier}}$

Legend

- w = load (lbs/ft)
- W = total load across span (lbs)
- F = design stress (lbs/in²)
- L = span (inches)
- Sx = section modulus for 2 rails (in³)
(see page APP-6 for Sx values)
- E = 10 million for Alum. (lb/in.²)
29 million for Steel (lb/in.²)
- Ix = moment of inertia for 2 rails (in⁴)
(see page APP-6 for Ix values)

Cable Tray Side Rails

Design Data For One Rail

Aluminum	B-Line series	Side Rail Height	A (in.)	B (in.)	C (in.)	D (in.)	E (in.)	Sx (in. ³)	Ix (in. ⁴)	Area (in. ²)	Weight (lbs./ft.)
	KSA4A	4	3.86	2.970	.059	1.36	.750	0.450	0.895	0.400	0.467
	KSA5A	5	4.860	3.970	.059	1.36	.750	0.620	1.540	0.458	0.536
	KSB4A	4	3.880	2.950	.067	1.36	.750	0.535	1.160	0.494	0.578
	KSB5A	5	4.880	3.950	.067	1.36	.750	0.735	1.980	0.559	0.654
	KSB6A	6	5.880	4.950	.067	1.36	.750	0.955	3.080	0.624	0.730
	RSI04	4	3.540	2.680	.059	1.71	.768	0.550	0.980	0.465	0.540
	RSI05	5	4.530	3.660	.061	1.71	.770	0.750	1.760	0.540	0.630
	RSI06	6	5.510	4.640	.059	1.71	.768	0.990	2.750	0.559	0.690
	RSI07	7	6.50	5.630	.075	1.71	.784	1.340	4.390	0.750	0.880
	24	4	4.120	3.050	.060	1.75	.740	0.670	1.430	0.525	0.620
	H24	4	4.185	3.105	.070	1.75	.750	0.785	1.845	0.640	0.745
	34	4	4.200	3.080	.100	1.75	.750	1.050	2.490	0.902	1.060
	25	5	5.000	3.930	.068	1.75	.748	0.900	2.310	0.620	0.720
	35	5	5.060	3.960	.090	1.75	.745	1.180	3.190	0.857	0.980
	26	6	6.120	5.040	.065	2.00	.745	1.260	3.950	0.698	0.820
	36	6	6.170	5.060	.075	2.00	.725	1.680	5.420	0.903	1.050
	46	6	6.190	5.080	.085	2.00	.650	1.790	6.090	0.989	1.170
	56	6	6.433	5.263	.140	2.12	.760	3.059	11.316	1.185	2.113
	H46	6	6.240	5.090	.130	2.00	.750	2.670	8.650	1.473	1.740
	27	7	7.140	6.058	.075	2.00	.725	1.465	5.640	0.810	0.943
	37	7	7.140	6.050	.075	2.00	.750	1.880	6.750	0.904	1.060
	47	7	7.240	6.130	.100	2.00	.675	2.470	8.940	1.189	1.400
	H47	7	7.240	6.090	.125	2.00	.675	3.050	11.460	1.520	1.770
	57	7	7.400	6.230	.160	2.00	.875	3.860	16.430	2.114	2.460
	S8A	8	8.000	6.170	.170	3.00	1.000	7.690	27.670	2.754	3.200

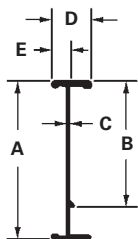

Steel	B-Line series	Side Rail Height	A (in.)	B (in.)	C (in.)	D (in.)	E (in.)	Sx (in. ³)	Ix (in. ⁴)	Area (in. ²)	Weight (lbs./ft.)
	148	4	3.625	3.125	.048	.875	—	.250	.450	.251	.840
	156	5	4.188	3.688	.060	.875	—	.360	.760	.340	1.160
	166	6	5.188	4.688	.060	.750	—	.460	1.200	.385	1.310
	176	7	6.188	5.688	.060	.750	—	.640	1.900	.444	1.520
	248	4	4.188	3.140	.048	1.000	.392	.320	.720	.313	1.170
	346	4	4.188	3.130	.060	1.500	.655	.480	1.110	.449	1.640
	444	4	4.188	3.110	.075	1.500	.670	.640	1.470	.561	2.020
	258	5	5.188	4.140	.048	1.000	.392	.450	1.220	.361	1.340
	356	5	5.188	4.130	.060	1.500	.655	.660	1.860	.509	1.860
	454	5	5.188	4.110	.075	1.500	.670	.870	2.480	.636	2.290
	268	6	6.188	5.140	.048	1.000	.392	.590	1.900	.409	1.520
	368	6	6.188	5.130	.048	1.500	.643	.710	2.390	.457	1.700
	366	6	6.188	5.140	.060	1.500	.655	.850	2.870	.569	2.080
	464	6	6.188	5.110	.075	1.500	.670	1.140	3.830	.711	2.560
	378	7	7.188	6.140	.048	1.500	.643	.890	3.450	.505	1.880
	476	7	7.188	6.130	.060	1.500	.655	1.070	4.150	.629	2.300
	574	7	7.188	6.110	.075	1.500	.670	1.430	5.550	.792	2.830

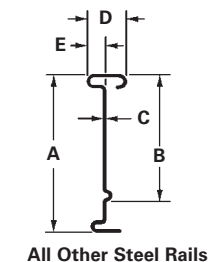
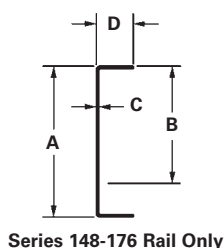

A - Side Rail Height B - Loading Depth C - Web Thickness D - Flange Width
 Design Factors: Ix = Moment of Inertia, Sx = Section Modulus

Series 1 Cable Tray

Steel Side Rail Weights

Tray Series		148	156	166	176
Weight for 2 Side Rails	lbs/ft	1.68	2.32	2.62	3.03
	kg/m	2.50	3.45	3.90	4.51

Example:

Weight for 148P09-12-144
 = 1.68 lbs/ft + .51 lbs/ft = 2.19 lbs/ft
 = (2.19 lbs/ft) (12 ft) = 26.28 lbs.

Tray Bottom Weights

Tray Width (inches)			6	9	12	18	24	30	36
All Series 1 Steel	6" Spacing	lbs/ft	0.38	0.57	0.76	1.14	1.52	2.25	2.70
	Rung Weight	kg/m	0.57	0.85	1.13	1.70	2.26	3.35	4.02
	9" Spacing	lbs/ft	0.25	0.38	0.51	0.76	1.01	1.50	1.80
	Rung Weight	kg/m	0.38	0.57	0.75	1.13	1.51	2.23	2.68
	12" Spacing	lbs/ft	0.19	0.29	0.38	0.57	0.76	1.13	1.35
	Rung Weight	kg/m	0.29	0.43	0.57	0.85	1.13	1.68	2.01
Series 156, 166 & 176 Steel	4" Vented	lbs/ft	0.57	0.86	1.14	1.71	2.28	3.37	3.42
	Rung Weight	kg/m	0.85	1.27	1.70	2.54	3.39	5.02	5.09
	Solid Bottom	lbs/ft	1.01	1.51	2.01	3.02	4.02	5.20	6.25
	Weight	kg/m	1.50	2.24	2.99	4.49	5.98	7.74	9.29

When using steel tray that is hot dip galvanized after fabrication add 9.6% to weights.

Series 2, 3, 4 or 5 cable tray

Aluminum Side Rail Weights

Tray Series		24	H24	34	25	35	26	36	46	H46	56	27	37	47	H47	57
Weight for 2 Side Rails	lbs/ft	1.23	1.49	2.12	1.44	1.96	1.64	2.09	2.33	3.47	4.22	1.88	2.12	2.80	3.54	4.92
	kg/m	1.83	2.22	3.15	2.14	2.92	2.44	3.11	3.47	5.16	6.29	2.80	3.15	4.16	5.27	7.32

Steel Side Rail Weights

Tray Series		248	346	444	258	356	454	268	368	366	464	378	476	574
Weight for 2 Side Rails	lbs/ft	2.34	3.28	4.04	2.68	3.72	4.58	3.04	3.40	4.16	5.12	3.76	4.60	5.66
	kg/m	3.48	4.88	6.01	3.99	5.54	6.82	4.52	5.06	6.19	7.62	5.59	6.84	8.42

Series 2, 3, 4 or 5 weights continued on page 387.

Appendix - Reference Material - Cable Tray Weights

Series 2, 3, 4 or 5 cable tray

Tray Bottom Weights

Tray Width (inches)			6	9	12	18	24	30	36	42
All Series 2,3,4 Aluminum	6" Spacing	lbs/ft	0.30	0.44	0.59	0.89	1.18	1.70	2.04	2.38
	Rung Weight	kg/m	0.44	0.66	0.88	1.32	1.76	2.53	3.04	3.54
	9" Spacing	lbs/ft	0.20	0.29	0.39	0.59	0.78	1.13	1.36	1.58
	Rung Weight	kg/m	0.29	0.44	0.58	0.87	1.16	1.68	2.02	2.35
	12" Spacing	lbs/ft	0.15	0.22	0.29	0.44	0.58	0.85	1.02	1.19
	Rung Weight	kg/m	0.22	0.32	0.43	0.65	0.86	1.26	1.52	1.77
All Series 2,3,4,5 Steel	6" Spacing	lbs/ft	0.62	0.92	1.23	1.85	2.46	3.67	4.40	5.14
	Rung Weight	kg/m	0.92	1.37	1.83	2.75	3.66	5.46	6.55	7.65
	9" Spacing	lbs/ft	0.41	0.62	0.82	1.23	1.64	2.45	2.94	3.43
	Rung Weight	kg/m	0.61	0.92	1.22	1.83	2.44	3.65	4.37	5.10
	12" Spacing	lbs/ft	0.31	0.47	0.62	0.93	1.24	1.84	2.21	2.58
	Rung Weight	kg/m	0.46	0.69	0.92	1.38	1.85	2.74	3.29	3.83
	18" Spacing	lbs/ft	0.21	0.31	0.41	0.62	0.82	1.22	1.46	1.71
	Rung Weight	kg/m	0.31	0.46	0.61	0.92	1.22	1.82	2.18	2.54

When using steel tray that is hot dip galvanized after fabrication add 9.6% to weights.

Fiberglass cable tray

Fiberglass Side Rail Weights

Tray Series		13	24	36	46	H46	48
Weight for 2 Side Rails	lbs/ft	1.40	1.78	2.82	3.72	3.72	4.66
	kg/m	2.08	2.65	4.20	5.54	5.54	6.93

Fiberglass Bottom Weights

Tray Width (inches)			6	9	12	18	24	30	36
All Series Fiberglass	6" Spacing	lbs/ft	0.54	0.81	1.08	1.62	2.16	2.70	3.23
	Rung Weight	kg/m	0.80	1.20	1.60	2.41	3.21	4.01	4.81
	9" Spacing	lbs/ft	0.35	.053	0.70	1.05	1.40	1.75	2.10
	Rung Weight	kg/m	0.52	0.78	1.04	1.56	2.09	2.61	3.13
	12" Spacing	lbs/ft	0.27	0.40	0.54	0.81	1.08	1.35	1.62
	Rung Weight	kg/m	0.40	0.60	0.80	1.20	1.60	2.01	2.41
	18" Spacing	lbs/ft	0.19	0.28	0.38	0.57	0.75	0.94	1.13
	Rung Weight	kg/m	0.28	0.42	0.56	0.84	1.12	1.40	1.68
	6" Spacing Marine Rung Wt.	lbs/ft	0.75	1.12	1.49	2.24	2.98	3.73	4.48
		kg/m	1.11	1.67	2.22	3.33	4.44	5.55	6.66
	9" Spacing Marine Rung Wt.	lbs/ft	0.48	0.73	0.97	1.45	1.94	2.42	2.91
		kg/m	0.72	1.08	1.44	2.16	2.89	3.61	4.33
	12" Spacing Marine Rung Wt.	lbs/ft	0.37	0.56	0.75	1.12	1.49	1.87	2.24
		kg/m	0.56	0.83	1.11	1.67	2.22	2.78	3.33
	18" Spacing Marine Rung Wt.	lbs/ft	0.26	0.39	0.52	0.78	1.04	1.31	1.57
		kg/m	0.39	0.58	0.78	1.17	1.55	1.94	2.33

AMPACITY:

Multiconductor Cables (2000 Volts or Less)

Cable ampacities shall comply with Tables 310.16 and 310.18 of the NEC® subject to the provisions below:

1. If there are more than 3 current carrying conductors in a cable, derate cable ampacity per section 310.15(B)(2)(A).
2. If tray has solid covers, use 95% of the ampacity values shown in Tables 310.16 and 310.18.
3. If cables are placed in a single layer, with a maintained spacing of not less than 1 cable diameter between cables, the ampacity of the cables shall not exceed the allowable ambient temperature-corrected ampacities of multiconductor cables with not more than 3 insulated conductors in free air in accordance with Section 310.15(C) and Table B.310.3. You must use the ambient ampacity correction factors, found below Table B.310.3, for ambient temperatures other than 40°C (104°F).

Multiconductor Cables (2001 Volts and over) Type MV and Type MC Cables

1. Where cable trays are covered for more than 6 ft. with solid, unventilated covers, use not more than 95% of the ampacity values of Tables 310.75 and 310.76.
2. Where cables are installed in a single layer in uncovered trays with a maintained spacing of not less than one cable diameter between cables, you can use the ampacity values listed in Tables 310.71 and 310.72.

Single Conductor Cables

Ampacity of Cables Rated 2000 Volts or Less in Cable Tray (single conductor cables)

Cable Sizes	Solid Unventilated Cable Tray Cover ?	Applicable Ampacity Tables (*)	Mult. Amp. Table Values By	Special Conditions
600 kcmil and Larger	No (**)	310.17 and 310.19	0.75	
600 kcmil and Larger	Yes	310.17 and 310.19	0.70	
1/0 AWG through 500 kcmil	No (**)	310.17 and 310.19	0.65	
1/0 AWG through 500 kcmil	Yes	310.17 and 310.19	0.60	
1/0 AWG & Larger In Single Layer	No (**)	310.17 and 310.19	1.00	Maintained Spacing Of One Cable Diameter
Single Conductors In Triangle Config. 1/0 AWG and Larger	No (**)	310.20 [See NEC Section 310.15(B)]	1.00	Spacing Of 2.15 x One Conductor O.D. Between Cables

Ampacity of Type MV and Type MC Cables (2001 Volts or over) in Cable Trays (single conductor cables)

Cable Sizes	Solid Unventilated Cable Tray Cover ?	Applicable Ampacity Tables (*)	Mult. Amp. Table Values By	Special Conditions
1/0 AWG and Larger	No (**)	310.69 and 310.70	0.75	
1/0 AWG and Larger	Yes	310.69 and 310.70	0.70	
1/0 AWG & Larger In Single Layer	No (**)	310.69 and 310.70	1.00	Maintained Spacing Of One Cable Diameter
Single Conductors In Triangle Config. 1/0 AWG and Larger	No (**)	310.67 and 310.68	1.05	Spacing Of 2.15 x One Conductor O.D. Between Cables

(*) The ambient ampacity correction factors must be used.

(**) At a specific position, where it is determined that the tray cables require mechanical protection, a single cable tray cover of six feet or less in length can be installed.

Cable Fill in Hazardous (Classified) Locations:

Section 392.3 of the NEC regulates the use of cable tray wiring systems in hazardous (classified) locations. This section states that if cable tray wiring systems are installed in hazardous (classified) locations, the cables that they support must be suitable for installation in those hazardous (classified) locations. The cable carries the installation restriction, not the cable tray except that the cable tray installation must comply with Section 392.4.

Some hazardous (classified) locations require special spacing of the cables. When installing Type MC, MI & TC cables in cable tray in Class II, Division 2 Hazardous (classified) areas, (combustible dusts), the cables are limited to a single layer with spacing between cables equal to the diameter of the largest adjacent cable. This is the only hazardous (classified) location where the spacing of the cables is required although it is recommended that this wiring method also be employed in Class III, Division I, and Class III, Division 2 (Ignitable Fibers & Flyings). Please note that this will alter the cable tray sizing information obtained from the sizing flow chart on page C-20 & C-21 of this catalog.

Please reference **NEMA VE 2**, metal cable tray installation guideline, for more complete information.
Eaton.com/cabletray

Supports - Eaton's B-Line series cable tray shall be sized and installed as a complete cable support system appropriate for the cable types installed. Recommended cable tray support locations are as shown below. Do not exceed the maximum support spacing and design load as printed on the side rail label. Refer to Canadian Electrical Code (CEC) section 12-2202 for minimum cable tray clearances.

Splice Plates - Use factory supplied splice plates only. Splice plates located at the quarter span between supports are preferred. Avoid placing splices at midspan and directly above supports. Torque all splice plate fasteners to 19 ft. - lbs. for $\frac{3}{8}$ " and 50 ft. - lbs. for $\frac{1}{2}$ ". Expansion splice plate fasteners should be loosened $\frac{1}{2}$ turn after reaching full torque to allow for travel. Set the side rail gap for expansion plates according to the chart on page C-8 and ensure that a support is located within 2 feet on each side of the expansion splice.

Conductors - The Cable Tray system installation shall be completed prior to pulling conductors. Cable support distances for conductor size should be referenced in CEC Part 1, Table 21. Single conductor cables placed one diameter or more apart in ventilated or ladder type tray are allowed to use the free air rating per the CEC. Any conductor in vertical runs of cable tray and all single conductor cables must be fastened to the rungs with nylon cable ties or stainless steel clamps. Carbon steel cable clamps should not be used due to induction heating, per CEC section 12-2204 (5).

Covers - Vertical cable trays which penetrate dry floors must be covered for 2m (two meter) above the floor level. All cable tray dead ends must be closed with blind ends per CEC section 12-2202.

Handling - Cable tray is shipped without exterior crating, therefore careful material handling practices should be used. Cable tray straight sections should be lifted with wide slings and an overhead crane. If a crane is not available and a fork lift is to be used, only single bundles should be lifted. Ensure that each bundle is properly centered. Cable tray fittings that are not crated should be unbanded and off-loaded by hand.

Storage - All cable tray materials are subject to storage stain (white rust) if improperly stored. If cable tray is stored as shipped, it must be stored indoors. If the cable tray material must be stored outside, it must be unbanded and loosely stacked on an angle to minimize the components' contact area as well as provide for adequate drainage.

NEMA RECOMMENDED SUPPORT LOCATIONS FOR FITTINGS

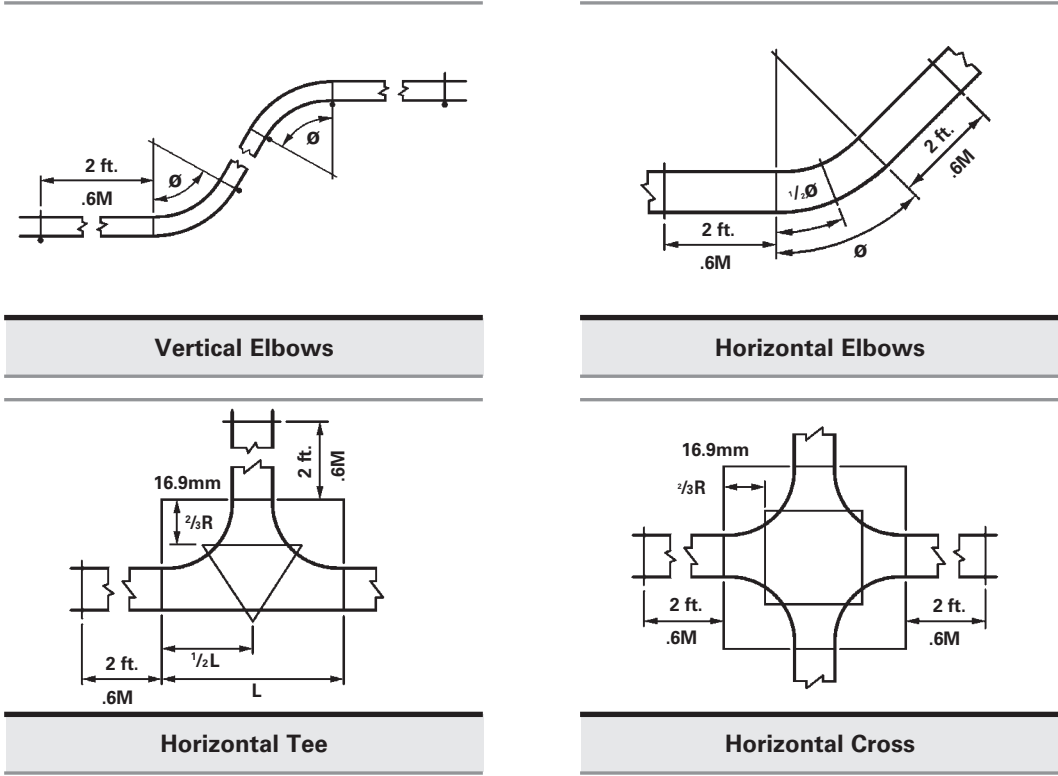

Appendix

Channel Sizes & Hole Patterns Selection Chart

TH Channel Type	Channel Dimensions		Material & Thickness				Channel Hole Patterns **			
	Height	Width	Stainless				SH	S	H17/8	
			1	2	3	4				
			Steel	Aluminum	Type 304	Type 316				
B11	3 1/4"	1 5/8"	12 Ga.	—	—	—	1	1	1	—
B12	2 7/16"	1 5/8"	12 Ga.	.105	—	—	1,2	1	1,2	—
B22	1 5/8"	1 5/8"	12 Ga.	.105	12 Ga.	12 Ga.	1,2,3,4	1	1,2,3,4	1
B24	1 5/8"	1 5/8"	14 Ga.	.080	14 Ga.	14 Ga.	1,2,3,4	1	1,2,3,4	—
B26	1 5/8"	1 5/8"	16 Ga.	—	—	—	1	1	1	—
B32	1 3/8"	1 5/8"	12 Ga.	—	12 Ga.	—	1,3	1	1,3	—
B42	1 "	1 5/8"	12 Ga.	—	12 Ga.	—	1,3	1	1,3	—
B52	1 3/16"	1 5/8"	12 Ga.	—	12 Ga.	—	1,3	1	1,3	—
B54	1 3/16"	1 5/8"	14 Ga.	.080	14 Ga.	14 Ga.	1,2,3,4	1	1,2,3,4	—
B56	1 3/16"	1 5/8"	16 Ga.	—	—	—	1	1	1	—

Available Finishes on Steel: Plain (Oil Coated), Dura-Green Epoxy, Pre-Galvanized, and Hot Dip Galvanized are standard.

- ** 1 - Steel
- 2 - Aluminum
- 3 - Type 304 Stainless Steel
- 4 - Type 316 Stainless Steel

Channel Nuts

With Spring			Without Spring		Twirl Nut		Thread Size	Thickness
B11 B12	B22 B24 B32	B42 B52 B54	B11 B22 B12 B24 B32	B42 B52 B54	B11 B22 B12 B24 B32	B42 B52 B54		
N728	N228	N528	N228WO	N228WO	TN228	TN228	3/8"-16	3/8" for all nuts
N725	N225	N525	N225WO	N525WO	TN225	TN525	1/2"-13	1/2" for N725,N225,N225WO,TN225 3/8" for N525,N525WO,TN525
N755	N255	N555	N255WO	N555WO	—	—	5/8"-11	1/2" for N755,N255,N255WO 3/8" for N555,N555WO

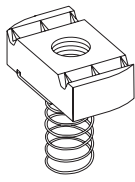

Channel Nut With Spring

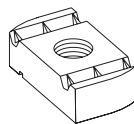

Channel Nut Without Spring

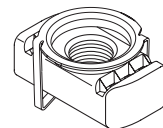

Twirl Nut

For other channels, channel nuts, and fittings see B-Line series Strut Systems Catalog.

Continuous Concrete Insert

Catalog Number for Channel		Channel Size	Maximum Depth	Load
120" (10 ft.)	240" (20 ft.)			
B22I-120	B22I-240	B22	1 ⁵ / ₈ "	2000 lbs./ft.
B32I-120	B32I-240	B32	1 ³ / ₈ "	2000 lbs./ft.
B52I-120	B52I-240	B52	1 ³ / ₁₆ "	1500 lbs./ft.

Safety factor of 3 on loading.

Other lengths available upon request.

Furnished with end caps and styrofoam filler installed.

Standard finishes:

- Plain (Oil Coated)
- Dura Green Epoxy
- Pre-Galvanized
- Hot Dip Galvanized

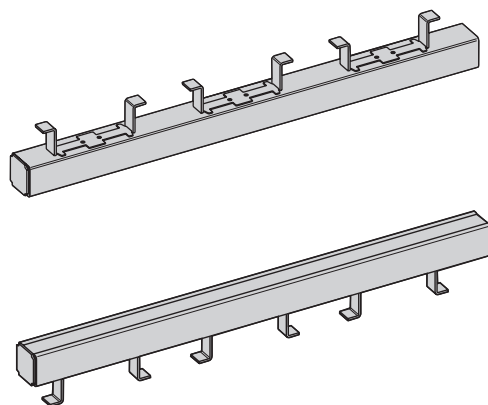

B2500 Spot Insert & N2500 Insert Nut

Standard Finish: Zinc Plated

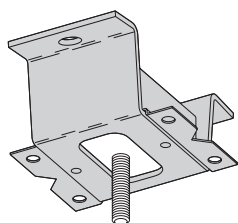

B2500 Insert

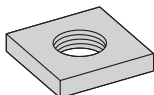

N2500 Insert Nut
Insert rod size behind part number.

Square Nuts for Spot Inserts

Concrete Insert Applications

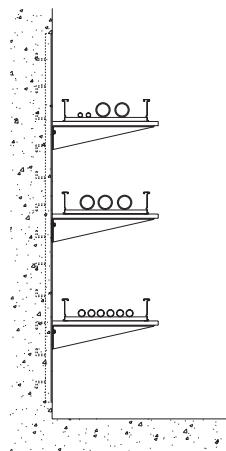

Continuous inserts used vertically are ideal mounting bases for cable tray brackets.

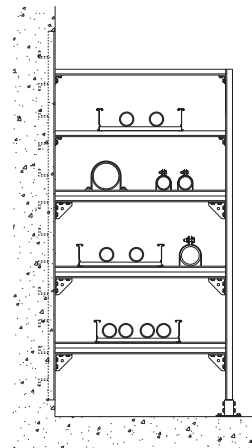

For multi-tiered tray assemblies, inserts function as the anchors for each stanchion.

Angle Fittings

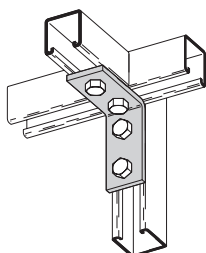

B104

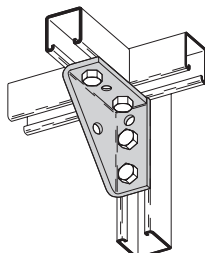

B844

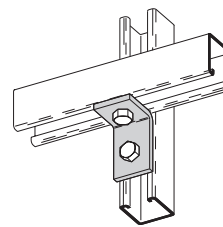

B101